

The DEEC and EDEEC Heterogeneous WSN Routing Protocols

Kenza Redjimi

Department of Computer Science, Université 20 Août 1955, LICUS Laboratory, Skikda - Algeria
Emails: k.redjimi@univ-skikda.dz

Mohammed Redjimi

Department of Computer Science, Université 20 Août 1955, LICUS Laboratory, Skikda - Algeria
Emails: medredjimi@gmail.com

ABSTRACT

Wireless Sensor Networks are autonomic nodes disseminated in a large area of interest. These small units are capable of taking various measurements of their environment and sending them to distant base stations (BS) for further scheduling. Typical WSNs are composed of a great number of nodes, which have elementary energies and resources. This paper discusses the heterogeneous protocols of wireless sensor networks by targeting particularly two heterogeneous WSN routing protocols DEEC and EDEEC, which have several common characteristics, however DEEC is a protocol with two energy levels while EDEEC determines three energy levels. Some comparisons between the DEEC and the EDEEC heterogeneous WSN routing protocols are made and discussed in this paper. Three factors characterize the WSN Heterogeneity: The amount of initial energies, the signal power and the computational resources. In this paper, only energy aspect is considered.

Keywords – WSN, routing protocols, heterogeneous WSN, hierarchical protocols, DEEC, EDEEC.

Date of Submission: Jan 25, 2022

Date of Acceptance: Feb 05, 2022

I. INTRODUCTION

Wireless data transmission is a powerful technology, which enable remote communication by using radio signals. Nowadays, recent progress in the Micro and Nano machines (MEMS) and (NEMS) [1] paves the way for an intensive use of the wireless technology in different disciplines: remote control, cellular phones, Internet of things, Among these new applications are the Wireless Sensor Networks (WSN) [2]. A WSN is composed of a huge number of sensor nodes deployed in a large area for local data extracting and sending them to remote base stations (BS). The WSN nodes are elementary units with few processing and storage capabilities. In addition, batteries supply the energy power of the nodes. When the nodes are localized in hostile or unreachable areas, batteries cannot be rechargeable and the network lifetime is, therefore, shortened. To resolve this problem, researchers proposed several approaches and algorithms implemented in routing protocols. Direct communication between the nodes and the base station is not an optimal and efficient solution from the point of view of energy management for two essential reasons. Firstly; the nodes furthest from the base station use up their energy more quickly than those which are closest. On the other hand, the signal strength of a remote node may be insufficient to reach the base station. It is, therefore, necessary to think about other approaches aiming at a fairer distribution of energy expenditure and guaranteeing the flow of data to the base station. The LEACH routing protocol is one of the earliest protocols [3] among the most popular of the WSNs protocols. Several other protocols inspired by LEACH while making improvements have been updated and are operational. LEACH considers homogeneous

WSNs, in the sense that the nodes composing these networks have all the same initial energies and have the same resources (CPU, Memory...). There are many other routing protocols and several criteria can be adopted for their rankings. Among these protocols, it is appropriate to quote the flat protocols where all the nodes play the same roles and the geographical protocols, which use the geographical position of a node; the diffusion being made towards the neighboring nodes in the direction of the BS.

An important improvement for energy optimization lies in the use of heterogeneous WSNs. In this second case, the initial energy distribution of the sensor nodes is different. The resources equipping each node can be different and the radio signal strengths, too, different.

The routing protocols used in homogeneous WSNs lose in efficiency when they are applied in cases of heterogeneity and other more specific protocols have been devised and implemented. Among these protocols, DEEC [4] and EDEEC [5] [6] present interesting characteristics and it is in this context that the work presented here is situated. In this work, only the heterogeneity linked to the initial energy of the sensor nodes is considered.

The contribution of this paper is based on the experimental verification, which consists in observing that the addition of a level of heterogeneity makes it possible to improve the performance of the wireless sensor networks. This is the case between the DEEC (two heterogeneity levels) and EDEEC (three heterogeneity levels) protocols.

The rest of the paper is organized as follows: Section 2 presents some related works. Section 3 is devoted to introduce basic elements of the WSN. Section 4 describes the heterogeneous model for wireless sensor networks. In section 5 a simulation case and the discussion of the

obtained results are presented. Lastly, Section 6 concludes this paper.

II. RELATED WORKS

The main limitation of WSNs is that the sensor nodes are operating on limited power sources. Therefore, several routing protocols for WSNs are implemented in order to have an equal energy consumption for the sensor nodes [7]. A routing protocol for wireless sensor networks consists to find the optimal communication way and to establish the correct and efficient route between a pair of nodes by respecting the energy consumption and network lifetime factors [8]. We can consider the one hop and the multi-hop route. In the one hop approach, data are transmitted directly between the sender and the receiver, while in the multi-hop mode the data transit by two or more intermediate stations. Direct communication between a sensor node and the base station (BS) is not an efficient solution since it consumes a lot of energy and the base station can be located outside the node signal range. Thus, several protocols have been proposed and many of them are implemented. Three important classes of protocols can be distinguished: flat, hierarchical, and location-based routing protocols. One can distinguished two categories in flat routing protocols that are On-Demand protocols (such as Dynamic Source Routing (DSR) [9] and Ad hoc On-demand Distance Vector (AODV) [10,11] or Table-Driven protocols such as Destination Sequenced Distance Vector (DSDV) [12]. In the case of hierarchical protocols, sensor nodes are not in direct communication link with the base station. The nodes are grouped together to form clusters. In each cluster, a cluster head is periodically elected to receive the data from the various constituents of the cluster and to aggregate them, and furthermore to route these aggregated data to remote base stations. Low-energy adaptive clustering hierarchy (LEACH) [3] and its variants are among the typical implementations of this class of protocols. An interesting other class of protocols is the location-based routing protocols (so-called geographic protocols). In this latter case, each node transmits its data to its closets neighbour that is in the direction of the base station. In Geographic Routing, each node is concerned only with its one-hop neighbours. For example, Greedy Perimeter Stateless Routing (GPSR) [12] and IEEGR [13] are geographic routing protocols.

One can consider two categories of wireless sensor network's properties: homogenous and heterogeneous. In the first category, all the nodes have the same amount of initial energy and the same hardware capability, but in the heterogeneous network, there are different levels of nodes equipped with different amounts of initial energies the hardware and software requirements may be, also, different.

Many protocols for homogeneous and heterogeneous wireless sensor network are developed. Among the first homogenous protocols are LEACH [3], Power-Efficient Gathering in Sensor Information Systems (PEGASIS) [14] and Hybrid Energy-Efficient Distributed Clustering (HEED) [15]. Homogeneous protocols are not efficient in

the heterogeneous networks. In heterogeneous WSNs, nodes have different initial energy levels. Among this kind of protocols, one can distinguish the following: Distributed Energy Efficient Clustering (DEEC) [4], Developed DEEC (DDEEC) [16], Enhanced Developed Distributed Energy-efficient Clustering (EDDEEC) [17], Enhanced DEEC (EDEEC) [5], stable election protocol (SEP) [18], Balanced Energy Efficient Network Integrated Super Heterogeneous (BEENISH) [19], modified BEENISH [20] are protocols for heterogeneous WSNs.

III. BACKGROUNDS

A. The network model

The basic configuration of a sensor network can be represented as follow (figure 1). The following assumptions are made on the network model and can be used for simulating sensor region:

- The sensor nodes and the base station are assumed stationary once they are deployed in the environment and their locations are fixed.
- Wireless sensor network includes heterogeneous sensor nodes.
- The base station is not limited in terms of energy, memory and computing power.
- The nodes are eligible to determine its current energy level and location information through GPS service.
- All the sensor nodes are immobile and having fixed node id.
- Data aggregation is done only at CH nodes

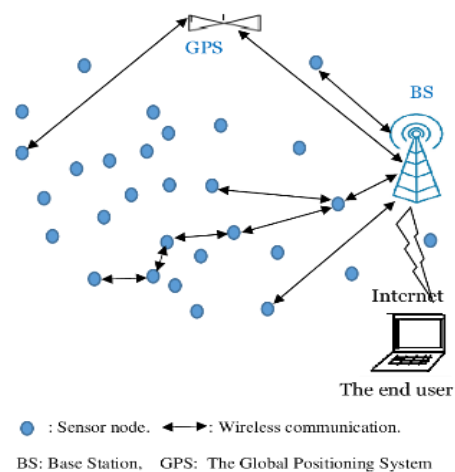

Figure 1. A WSN deployment.

B. The sensor node configuration

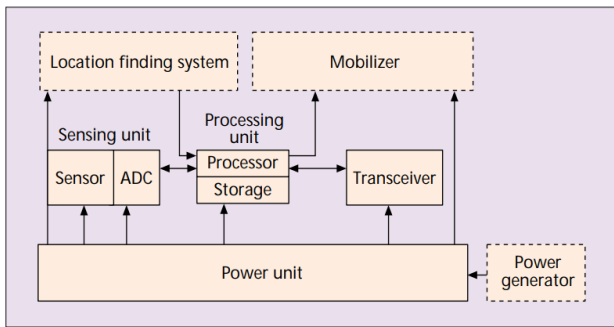

Figure 2. Hardware components of a sensor node

Basic components of a sensor node are:

- The sensor unit, which is a device able to convert physical quantities in analogic electric signals. There are often units integrating several functions for capturing different physical signals (humidity, luminosity, temperature, etc.) in order to avoid the multiplication of components.
- The Analog to Digital converter (ADC) unit: This unit converts the analogic electric signals into digital signals. The obtained signals are transmitted to the microprocessor system for the processing step.
- The processing and storage unit: it is, generally, a microprocessor-based system with memories for data and programs storage. Space and cost constraints mean that these elements are optimized to the maximum. In the simplest configurations, the microprocessor is reduced to a simple microcontroller or even a PLC. For the more complex configurations, it will be a need of using efficient microprocessors or Digital Signal Processing (DSP) units that can execute signal or image processing algorithms. In this case, the response time and latency are reduced but the energy consumption is augmented.
- The transceiver: It is the unit allowing wireless communication between the sensor node and its environment. This communication is established in both directions: sending and receiving signals. Note that sending signals requires much more energy than receiving them. To this end, this unit is equipped with antennas for transmitting / receiving radio waves and electronic systems for their shaping and amplification.
- The location finding system: This system makes it possible to locate the position of the sensor node. It is often a unit capable of establishing connections with the GPS. Although very useful for locating sensor nodes, the energy expenditure is often high.
- The mobilizer: It is the unit making it possible to manage the mobility of the sensor node and its changes in location.
- The power generator: This unit makes it possible to supply the sensor node with additional energy and to recharge the battery when the location

conditions of the sensor node allow it. It is usually question of electricity generators by transforming natural and non-polluting energies (energies: solar, wind, hydraulic, tides, etc.). This energy contribution makes it possible to extend the life of the network if all the nodes can benefit from it.

- The power unit: It is the main supply unit (sometimes the only one) of the sensor node in electrical energy. There are most often batteries for which recharging or replacement is impossible when the node is located in hostile places or out of reach (underground, ocean floor, nuclear power plants, jungle, etc.). The optimal management of this electrical energy is among the points most studied by researchers.

C. The energy model

The energy consumption model proposed in this paper is depicted in fig. 3. This model follows the same radio model used in [3]. Therefore, the transmitter dissipates the energy for the transmission of k data bits as the following

(1):

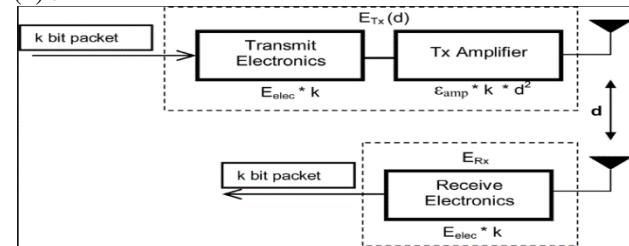

Figure 3. The energy model.

$$E_{tx}(k, d) = \begin{cases} E_{elec} \times k + E_{fs} \times k \times d^2, & d \leq d_0 \\ E_{elec} \times k + E_{amp} \times k \times d^4, & d > d_0 \end{cases}, \quad d_0 = \sqrt{\frac{E_{fs}}{E_{amp}}} \quad (1)$$

(1) concerns the energy consumed by the transmitter when sending k bits, where $E_{tx}(k, d)$ is the dissipated energy, E_{elec} is the Electronic devices energy, E_{fs} is the amplification energy in the free space, E_{amp} is the Power amplifier, d the transmission distance, d_0 is the threshold distance that depends on the environment and k is the number of the transmitted bits.

$$E_{rx}(k) = kE_{elec} \quad (2)$$

(2) is about the consumed energy when the receiving k bits.

Note that this energy is independent of the distance between the transmitter and the receiver. In this case, the distance influences the power of the received signal and its shape (noise, distortion, etc.).

IV. HETEROGENEOUS MODELS FOR WIRELESS SENSOR NETWORKS

Three sources of heterogeneity can be distinguished in a wireless sensor network:

- The heterogeneity related to the software and hardware architecture of sensor nodes. In this type of case, the sensor nodes are not equipped with the same components and software. The hardware architecture is different and some nodes have much more processing and storage power than the others. The control and application software can also be different.
- The heterogeneity related to the signal strength and bandwidth. Some nodes have better radiation capabilities than others, which means that they can transmit a radio signal at farther distances than others. Likewise, certain sensor nodes can have wider bandwidths and can have higher flow rates than the other nodes.
- Heterogeneity related to the initial amount of energy of the sensor nodes: This is one of the most studied specificities in the case of routing protocols in WSNs. In this case, the initial energies of the sensor nodes are different and, generally, energy levels are determined by grouping together sets of nodes having similar initial energies.

The energy heterogeneity is the most important studied criterion because when hardware, software, bandwidth and strength of radio signal are important, they will consume more energy resources.

Hierarchic heterogeneous routing protocols for WSNs are categorized by the energy efficiency, the heterogeneity levels, the stability, and the cluster heads (CH) selection. Optimal choices are conducted to elect the proper cluster head effectively, such as it upgrades the network lifetime up to a certain extent. In the following, two heterogeneous WSN protocols are presented: The DEEC and the EDEEC protocols.

A. The Distributed Energy Efficient Clustering Protocol for Heterogeneous Wireless Sensor Networks (DEEC):

In [4] Li Qing and al. proposed the Distributed Energy Efficient Clustering Protocol for Heterogeneous Wireless Sensor Networks (DEEC). This is a two-level clustering protocol for heterogeneous WSN. DEEC considers two types of nodes: normal nodes, which have initial low energy and advanced for nodes equipped with higher initial energy levels. DEEC uses initial and residual energy levels of nodes to select the CHs. This selection is based on a probability on the ratio between residual energy of each node and the average energy of the network.

Let E_0 and E_{0a} represent the initial energies of the normal and the advanced nodes respectively (a denotes how many times energies of advanced node has been relative to normal node). Let N be the total number of sensors in the network (3).

$$N = N_{nml} + N_{adv} = N(1-m) + N_m \quad (3)$$

Where N_{nml} represents the number of normal nodes and N_{adv} is the number of advanced nodes. m is the fraction of the advanced nodes ($0 < m < 1$)

The total first energies of the normal and advanced nodes are calculated by (4) and (5)

$$E_{nml} = N_{nml}E_0 \quad (4)$$

$$E_{adv} = N_{adv}E_0 + aN_{adv}E_0 = N_{adv}E_0(1+a) \quad (5)$$

(6) calculates the total first energy:

$$E_{total} = E_{nml} + N(1-m)E_0 + N_m(E_0 + aE_0) = NE_0(1-m+m+ma) = NE_0(1+ma) \quad (6)$$

(7) gives the average energy of the network for the r^{th} round:

$$E_{avg} = \frac{1}{N} E_{total} (1 - \frac{r}{R}) \quad (7)$$

E_{total} represents the energy of the N nodes, R the number of the alive network rounds, and E_{round} is the consumed energy for each round (8).

$$R = \frac{E_{total}}{E_{round}} \quad (8)$$

In (9), P_i is the probability of a node S_i to become CH in a round r . At the beginning of each round, each node proposes a random probabilistic number and if this number is less than the threshold $T(S_i)$ then S_i is eligible to become a CH (10).

For the DEEC protocol, the probability for normal and advanced node is given by (10). P_{opt} is a determinate value that represents the fraction of the cluster numbers in the network ($0 < P_{opt} < 1$)

$$P_i = \begin{cases} \frac{E_i(r)P_{opt}(1+a)}{(1+am)E_{avg}} & \text{if normal node} \\ \frac{E_i(r)P_{opt}}{(1+am)E_{avg}} & \text{if advanced node} \end{cases} \quad (9)$$

$$T(S_i) = \begin{cases} \frac{P_i}{1 - P_i(\text{mod}(r, \frac{1}{P_i}))} & \text{if } S_i \in G \\ 0 & \text{otherwise} \end{cases} \quad (10)$$

B. The enhanced Distributed Energy Efficient Clustering Protocol for Heterogeneous Wireless Sensor Networks (EDEEC)

The Enhanced Distributed Energy Efficient Clustering protocol (EDEEC) was proposed by Parul Saini, Ajay.K. Sharma [5]. This is a three levels heterogeneous clustering protocol aiming to increase the lifetime and the stability of the network. The EDEEC protocol principle is based on the DEEC functioning protocol. However, there are three

kinds of nodes: normal, advanced and super nodes (11-14):

$$E_{nml} = NE_0(1-m) \quad (11)$$

$$E_{adv} = N_m E_0(1-m_0)(1+a) \quad (12)$$

$$E_{sup} = N m m_0 E_0(1+b) \quad (13)$$

$$E_{total} = NE_0(1+m(a+m_0b)) \quad (14)$$

Where a, b are a multiplicative factors of the initial energy E_0 ($b > a$), m and m_0 are fractions of super and advanced nodes in the network respectively

(15) calculates the probability P_i for a node S_i to become CH

$$P_i = \begin{cases} \frac{E_i(r)P_{opt}}{(1+m(a+m_0b))E_{avg}} & \text{if normal node} \\ \frac{E_i(r)P_{opt}(1+a)}{(1+m(a+m_0b))E_{avg}} & \text{if advanced node} \\ \frac{E_i(r)P_{opt}(1+b)}{(1+m(a+m_0b))E_{avg}} & \text{if super node} \end{cases} \quad (15)$$

The eligibility threshold $T(S_i)$ for S_i to become a CH is the same as in equation (11).

V. SIMULATION

For the system simulation, Table 1 depicts the used value parameters in the DEEC and the EDEEC protocols. Advanced nodes have $a = 1.5$ times more energy than normal nodes and super nodes, have $b=3$ times energy than normal nodes respectively. In this paper, we are interested essentially with the network lifetime and the packet transmission. Fig. 4 and 5 clearly show that the EDEEC protocol is significantly more efficient than DEEC in terms of network lifetime and packets transmitted to the BS.

Table 1. Simulation parameters

Parameters	Values
Network size	(100,100) m ²
Number of nodes	100
Normal nodes initial energy (E_0)	0.5 J
a	1.5
b	3
Eda (data aggregation)	5nj/bit
E_{elec}	50nj/bit
E_{fs}	10nj/bit/m ²
E_{amp}	0.0013 pj/bit/m ⁴
d_0	76m
P_{opt}	0.1
Sink position	(50,50) in the centre of the network
Fraction of super nodes (m)	0.3
Fraction of advanced nodes (m_0)	0.3

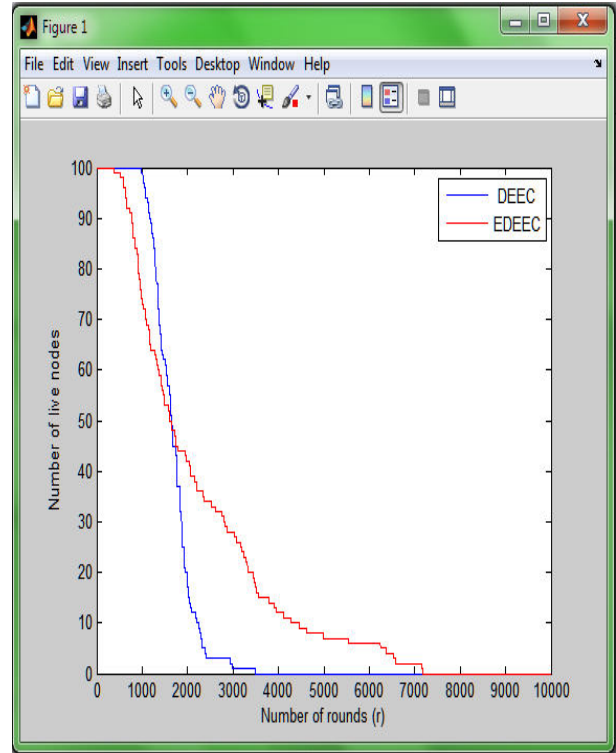

Figure 4. Number of alive nodes

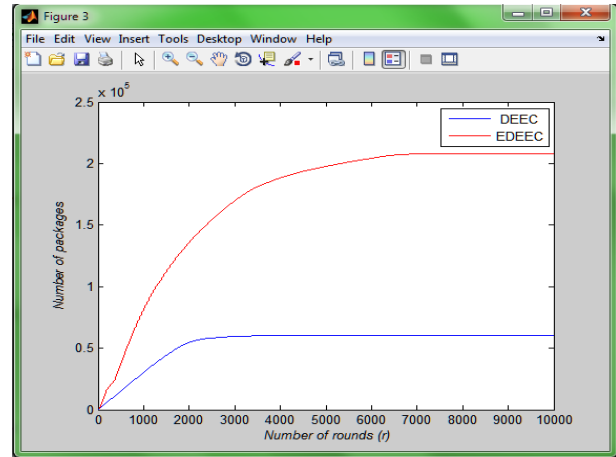

Figure 5. Number of transmitted packets

The fig. 4 and 5 show that EDEEC is more efficient than DEEC in terms of the network lifetime and the number of the transmitted packets to the BS. The EDEEC protocol increases the network lifetime of the network. In this simulation, the lifetime of the network and the number of delivered packets when we use the EDEEC protocol are enhanced by a factor two.

VI. CONCLUSION

In this paper, the DEEC and EDEEC heterogeneous WSN protocols are studied and compared. The simulation results show that EDEEC increases significantly the network performances. This study is only interested in the case of heterogeneity at two and three levels. In the next work, we

propose to address other protocols with higher levels of heterogeneity.

In addition to the fact that the Wireless sensor networks supply remote processing centers with information collected at the level of the environments in which they evolve, also make it possible to establish interactions between distant objects in ubiquitous and instantaneous ways. In future works, it is envisaged to study the impacts of these networks when they are disseminated on very large scales and the possible divisions according to their relative distributions by area of interest.

REFERENCES

- [1] Zhu, J., Liu, X., Shi, Q., He, T., Sun, Z., Guo, X., Liu, W., Bin Sulaiman, O., Dong, B. & Lee, C., Development trends and perspectives of future sensors and MEMS/NEMS. *Micromachines*, 11(1), 7 (2020). DOI: 10.3390/mi11010007
- [2] Kaur, M., Singh, L., A Survey on Mobile Sensing Technology and its Platform, *Int. J. Advanced Networking and Applications (IJANA)*, 9(4) , 2018 , 3523-3536.
- [3] Heinzelman, W. R., Chandrakasan, A., & Balakrishnan, H., Energy-efficient communication protocol for wireless microsensor networks. *In Proceedings of the 33rd annual Hawaii international conference on system sciences* (pp. 10-pp). IEEE, (2000, January).
- [4] Qing, Li, Qingxin Z., Mingwen W., Design of a distributed energy-efficient clustering algorithm for heterogeneous wireless sensor networks, *Computer Communications* volume 29 issue 12, pages 2230–2237, Elsevier Science Publishers B.V. Amsterdam, the Netherlands, (2006, August).
- [5] Saini, P., Sharma, A.K., E-DEEC- Enhanced Distributed Energy Efficient Clustering scheme for heterogeneous WSN, Parallel Distributed and Grid Computing (PDGC), *IEEE, 2010 first International Conference on*, 6 January (2011).
- [6] Katiyar, V., Chand, N., Soni S., A Survey on Clustering Algorithms for Heterogeneous Wireless Sensor Networks ,*Int. J. Advanced Networking and Applications (IJANA)*, 2(4) , 2011 ,745-754.
- [7] Karray, F., M. W. Jmal, A., Garcia-Ortiz, Abid, M., & Obeid, A. M. : A comprehensive survey on wireless sensor node hardware platforms. *Computer Networks*, 144, 89-110. (2018). DOI:10.1016/j.comnet.2018.05.010
- [8] Sharma, S., & Kaur, A., Survey on Wireless Sensor Network, and Its Applications *In Journal of Physics: Conference Series* (Vol. 1969, No. 1, p. 012042). IOP Publishing, (2021, July).
- [9] Johnson, D. B., Maltz, D. A., & Broch, J. (2001). DSR: The dynamic source routing protocol for multi-hop wireless ad hoc networks. *Ad hoc networking*, 5(1), 139-172.
- [10] Chakeres, I. D., & Belding-Royer, E. M., AODV routing protocol implementation design. *In 24th International Conference on Distributed Computing Systems Workshops, 2004. Proceedings, IEEE, 2004, March*, 698-703.
- [11] Singh, M., & Kumar, S., A survey: Ad-hoc on demand distance vector (AODV) protocol. *International Journal of Computer Applications*, 161(1), 2017, 38-44
- [12] AL-Dhief, F. T., Sabri, N., Salim, M. S., Fouad, S., & Aljunid, S. A., MANET routing protocols evaluation: AODV, DSR and DSDV perspective. *In MATEC web of conferences* (Vol. 150, p. 06024). EDP Sciences., 201, 2018.
- [13] Redjimi, K., Boulaiche, M., & Redjimi, M., IEGGR: Improved Energy-aware and Delivery Guarantee Geographic Routing. *Journal of Communications Software and Systems*, 17(2), 2021,143-153.
- [14] Lindsey, S., Raghavenda, C. S., PEGASIS: Power Efficient gathering in sensor information systems, *in Proceeding of the IEEE Aerospace Conference*, Big Sky, Montana, 2002, March.
- [15] Younis, O., Fahmy, S., HEED: A hybrid, energy-efficient, distributed clustering approach for ad hoc sensor networks, *IEEE Transactions on Mobile Computing*, 2004.
- [16] Elbhiri, B ., Saadane, R., El fldhi, S., Aboutajdine, D., Developed Distributed Energy-Efficient Clustering (DDEEC) for heterogeneous wireless sensor networks, *In I/V Communications and Mobile Network (ISVC), 5th International Symposium*, 30 Sept.- 2 Oct. 2010.
- [17] Javaid, N., Qureshi, T. N., Khan, A.H., Iqbal, A., Akhtar, E., Ishfaq, M., EDDEEC: Enhanced Developed Distributed Energy-efficient Clustering for Heterogeneous Wireless Sensor Networks, *International Workshop on Body Area Sensor Networks (BASNet - 2013)*, Published by Elsevier, 1877-0509, 2013.
- [18] Smaragdakis, G., Matta, I., Bestavros, A., SEP: A stable election protocol for clustered heterogeneous wireless sensor networks, *in: 2nd Int. Workshop on Sensor and Actor Network Protocols and Applications*, 2004, 1–11.
- [19] Qureshi, T. N., Javaid, N., Khan, A.H., Iqbal, A. , Akhtar, E., Ishfaq, M., BEENISH: Balanced Energy Efficient Network Integrated Super Heterogeneous Protocol for Wireless Sensor Networks, *The 4th International Conference on Ambient Systems, Networks and Technologies (ANT 2013)*, Volume 19, 24 June 2013, 920-925.

- [20] Preethi, A., Pravin, E. , Sangeetha, D., Modified Balanced Energy Efficient Network Integrated Super Heterogeneous Protocol, *2016 Fifth International Conference On Recent Trends In Information Technology, IEEE*, 2016.

Biography and Photograph

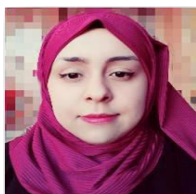

Kenza Redjimi obtained the BS. and Msc. degrees in computer science from university 20 Août 1955 – Skikda – Algeria respectively in 2017 and 2019. She is currently pursuing a PhD. in computer science at the same university.

Kenza Redjimi published several scientific articles, participated in several conferences and reviewed several articles. Her research interests include software engineering, modelling and simulation of industrial systems and wireless sensor networks.



Mohammed Redjimi obtained the engineer's degree in computer science from CERI (Centre d'études et de recherches en informatique) Algiers 1981, the DEA (Diplome des études approfondies) and the doctor-

Engineer's degree in computer science from LILLE 1 university (France) respectively in 1982 and 1984, then the Habilitation Universitaire (HDR) in computer science from Badji Mokhtar University – Annaba, Algeria in 2007.

Mohammed Redjimi was an assistant professor and researcher in computer science at Lille 1 university – Computer science department – France (1982- 1986). He is currently a Full professor at University 20 Août 1955, Skikda – Computer science department–Algeria, and the director of the LICUS laboratory at the same university. Mohammed Redjimi published and reviewed several scientific articles and participated in several research projects. He occupied several administrative, pedagogic and scientific functions such as dean of faculty, director of institute, and head of department. His present research interests include software engineering, modelling and simulation, multi-agent systems and wireless sensor networks.