



## Assessment of energy quality impacts for reactive power compensation with capacitor banks and D-STATCOM

### Evaluación de los impactos en la calidad de la energía por la compensación de potencia reactiva con bancos de condensadores y D-STATCOM

Santiago Benavides-Córdoba, José R. Ortiz-Castrillón, Yesika A. Gutiérrez-Villa,  
Nicolás Muñoz-Galeano, Juan B. Cano-Quintero, Jesús M. López-Lezama

**Para citar este artículo:** S. B. Benavides-Córdoba, J. R. Ortiz-Castrillón, Y. A. Gutiérrez-Villa, N. Muñoz-Galeano, J. B. Cano-Quintero, J. M. López-Lezama, "Assessment of energy quality impacts for reactive power compensation with capacitor banks and D-STATCOM", *Revista Vínculos: Ciencia Tecnología y Sociedad*, vol. 16, no. 2, julio-diciembre de 2019, pp. 232-241. DOI: 10.14483/2322939X.15752

Enviado: 12/05/19/ Recibido: 15/05/19/ Aprobado: 02/07/19

#### Abstract

This paper presents an assessment of capacitor banks and Distribution Static Compensator (D-STATCOM) with respect to their impact on energy quality. Tests were done with capacitor banks built with electrolytic capacitors commonly used in industrial applications and a D-STATCOM. Experimental tests were performed for power factor correction in order to reduce the reactive power demanded from the electrical grid for inductive-resistive loads. For comparative purposes, the control of the D-STATCOM was set to operate with similar compensation conditions to that of the capacitor banks. Results show that under the same test conditions capacitor banks produce higher Total Harmonic Distortion (THD) than D-STATCOM.

**Keywords:** Capacitor banks, D-STATCOM, power factor correction, energy quality, Total Harmonic Distortion.

#### Resumen

Este artículo presenta una evaluación de los bancos de capacitores y el Compensador Estático de Distribución (D-STATCOM) con respecto a su impacto en la calidad de la energía. Las pruebas fueron hechas con bancos de capacitores construidos con capacitores electrolíticos comúnmente usados en aplicaciones industriales y un D-STATCOM. Las pruebas experimentales fueron realizadas para corrección del factor de potencia, con el fin de reducir la potencia reactiva demandada por la red eléctrica con cargas resistivo-inductivas. Por propósitos comparativos, el control del D-STATCOM se programó para operar en similares condiciones de compensación respecto al banco de capacitores. Los resultados muestran que, bajo las mismas condiciones de prueba, los bancos de capacitores producen mayor Distorsión Armónica Total que el D-STATCOM.

1. Master en ingeniería, Universidad de Antioquia, Colombia, Medellín. Afiliación institucional: Grupo para el Manejo Eficiente de la energía, Universidad de Antioquia, Colombia. e-mail: [santiago.benavides@udea.edu.co](mailto:santiago.benavides@udea.edu.co) ORCID: <http://orcid.org/0000-0002-9207-866X>
2. Ingeniero electricista, Universidad de Antioquia, Colombia, Medellín. Afiliación institucional: Grupo para el Manejo Eficiente de la energía, Universidad de Antioquia, Colombia. e-mail: [jrobinson.ortiz@udea.edu.co](mailto:jrobinson.ortiz@udea.edu.co) ORCID: <http://orcid.org/0000-0002-3794-0982>
3. Estudiante de Ingeniería eléctrica, Universidad de Antioquia, Colombia, Medellín. Afiliación institucional: Universidad de Antioquia, Colombia. e-mail: [yesika.gutierrez@udea.edu.co](mailto:yesika.gutierrez@udea.edu.co) ORCID: <http://orcid.org/0000-0003-4265-9885>
4. Doctor en ingeniería Electrónica, Universidad de Antioquia, Colombia, Medellín. Afiliación institucional: Grupo para el Manejo Eficiente de la energía, Universidad de Antioquia, Colombia. e-mail: [nicolas.munoz@udea.edu.co](mailto:nicolas.munoz@udea.edu.co) ORCID: <http://orcid.org/0000-0003-1407-5559>
5. Doctor en ingeniería Electrónica, Universidad de Antioquia, Colombia, Medellín. Afiliación institucional: Grupo para el Manejo Eficiente de la energía, Universidad de Antioquia, Colombia. e-mail: [bernardo.cano@udea.edu.co](mailto:bernardo.cano@udea.edu.co) ORCID: <http://orcid.org/0000-0003-4767-1007>
6. Doctor en ingeniería Eléctrica, Universidad de Antioquia, Colombia, Medellín. Afiliación institucional: Grupo para el Manejo Eficiente de la energía, Universidad de Antioquia, Colombia. e-mail: [jmaria.lopez@udea.edu.co](mailto:jmaria.lopez@udea.edu.co) ORCID: <http://orcid.org/0000-0002-2369-6173>

**Palabras Clave:** Bancos de capacitores, D-STATCOM, corrección del factor de potencia, calidad de la energía, distorsión armónica total.

## 1. Introduction

Electrical industrial consumers must pay for excessive use of reactive energy. A power factor lower than 0.9 (either lagging or leading) is indicative of inadequate use of electrical energy and therefore is often penalized [1]–[4]. One of the effects of reactive power flows in transmission lines is the reduction of their transmission capacity. Excessive reactive power leads to lines and transformers oversized, reduction of active power supplied to users and undesired overgeneration due to higher power losses. Furthermore, excessive reactive energy circulation causes generation system destabilization, voltage drops and reduction of generator lifespan. Despite of the aforementioned facts, reactive energy plays a key role and is necessary to operate certain electrical devices. For these reasons, reactive power compensation is of paramount importance in order to reduce cost for users as well as generators and grid operators [5], [7], [8].

Reactive power compensation is usually performed by shunt capacitor banks which are located close to loads in industrial applications, being arrays of electrolytic capacitors in delta connection [8][13]. This compensation method is discrete (a fixed value is selected for an operation point) and presents inaccuracy in face of variable loads. In consequence, switching capacitor banks are used in order to add or remove capacitors according to the reactive energy demanded by the load in a given time period; nevertheless, there is a costly solution, introduces high current transients into the power system and can easily produce resonances due to the recurrent changes of the topology of the power system and the load. So, most of engineers prefer the use of Capacitor banks [5], [12], [14].

Distribution Static Compensator (D-STATCOM) is a power electronic device which dynamically compensates the reactive power and is presented as an alternative to capacitor banks [13], [15][17]. D-STATCOM continuously senses load variations and provides the energy required by the load; in consequence a D-STATCOM is able to

ensure a power factor close to 1 [18]. D-STATCOM incorporates a Voltage Source Converter (VSC) for generating three phase current signals, a DC bus to feed the VSC, inductors for grid coupling and also a control system [18], [19]. There are several topologies of D-STATCOM; however, the one featuring 3 branches and 6 pulses is the most common one for low voltage applications in electrical distribution systems (this topology presents the minimum number of switches per branch).

This paper presents an assessment of energy quality impacts for reactive power compensation with capacitor banks and D-STATCOM. While most common D-STATCOM applications typically focus on large loads, in this case, a low power application is approached. This is aligned with the new trend of distributed reactive power compensation that can be managed in microgrids. At present, this compensation type has been studied as evidenced in [20], [21]. The remaining of this paper is organized as follows: Section 2 presents a description of capacitor banks for power factor compensation, Section 3 presents a similar analysis for D-STATCOM, Section 4 presents the experimental results and finally, conclusions are presented in Section 5.

## 2. Compensation using Capacitor Banks

In a typical industrial installation, inductive loads are predominant, thus capacitor banks are employed to compensate their effect on the power factor. Capacitor banks are located close to loads in order to provide reactive energy so that the electrical grid would mostly provide active energy.

Capacitor banks are composed of electrolytic capacitors which exhibit non-linearities in their operation current [22][24]. Due to its internal structure, an electrolytic capacitor is a polarized element [24] which requires higher voltage on its positive terminal. Reverse polarization can lead to capacitor destruction and potential damage to other equipment or persons. To allow its operation in AC systems, a series connection of two electrolytic capacitors is employed as described below.

## 2.1. Single-Phase Compensation

Figure 1 shows the basic scheme of single-phase reactive energy compensation. In this case, the capacitor bank is composed of two capacitors in anti-series configuration. This connection prevents capacitor destruction in AC operation.

During the grid positive semi-cycle, capacitor c1 is correctly polarized and the lower capacitor is at reverse bias. Electrolyte from capacitor c2 becomes conductive and the capacitance from the upper capacitor limits the current avoiding its destruction; this happens analogously, during the negative semi-cycle. Note that this behavior is closer to a non-linear switching network than to an ideal linear capacitor.

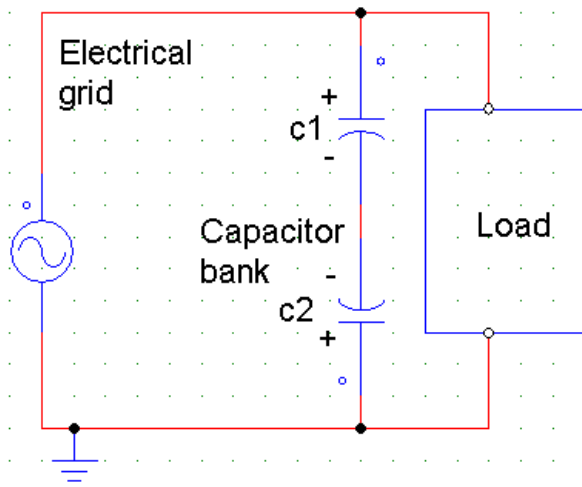

**Figure 1.** Single-phase compensation.  
Source: own.

Figure 2 presents a first-approximation model for the capacitor bank which was adapted from [25]. Figure 2a shows the circuitual model where ideal capacitors c1 and c2 have imperfect zener diodes Z1 and Z2 in parallel. Figure 2b presents the conduction path in positive grid semi-cycle; Z1 is reverse biased and current flows through c1 and Z2. In negative semi-cycle, Z2 is reverse biased and current flows through c2 and Z1 as shown in Figure 2c. The use of zener diodes allows to model capacitor rupture by over-voltage.

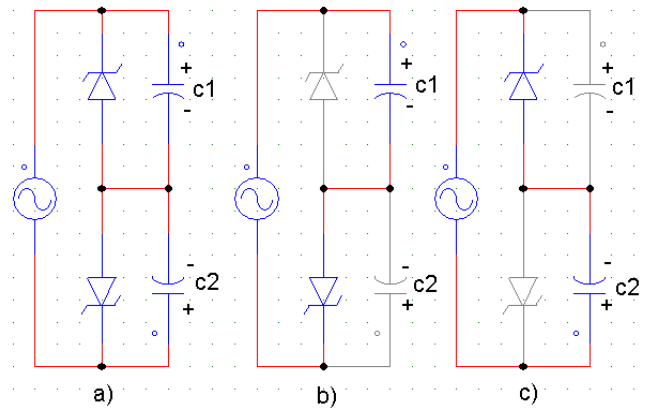

**Figure 2.** Capacitor bank operation: a) non-ideal model, b) positive semi-cycle and c) negative semi-cycle. Source: own.

## 2.1 Three-Phase Compensation

Figure 3 presents the equivalent circuit for a three-phase capacitor bank. In three-phase compensation, capacitor banks are built with three electrolytic capacitors in delta connection; basically, a three-phase bank is composed of three single-phase banks. Banks with wye connection are not commonly used due to the fact that their reactive compensation is lower than that of the delta connection and requires a higher voltage.

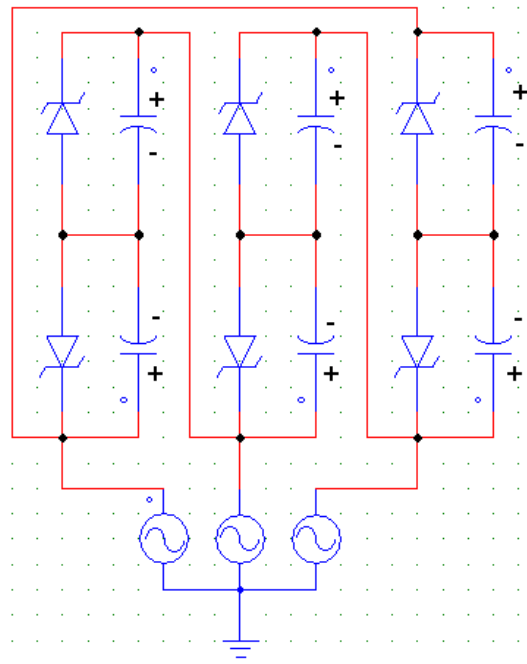
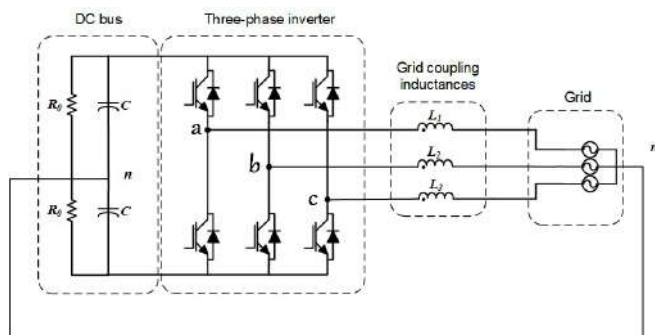

**Figure 3.** Three-phase compensation.  
Source: own.

In this section, a brief description of capacitor configurations for reactive power compensation was presented. Capacitor banks are essentially non-linear, even without considering other phenomena that affects linearity (capacitance dependence on voltage, dielectric conducting properties, leakage currents, dielectric absorption, etc). Thus, in its application to AC systems they are expected to cause signal distortion.

### 3. Compensation with D-STATCOM

D-STATCOM is a controlled power electronics device used to compensate reactive energy in centralized or decentralized form [26] [28]. Figure 4 presents the D-STATCOM topology, its main components are: a DC bus (composed of two capacitors) that provides a stable voltage supply for the Voltage Source Converter (VSC). VSC is a three-phase inverter with six switches used to generate the current signals for reactive compensation; each branch of D-STATCOM corresponds to a phase (a, b and c).



**Figure 4.** D-STATCOM topology.  
Source: own.

Compensation by means of D-STATCOM is illustrated in Figure 5. A typical industrial load demands active and reactive power ( $S_L = P_L + jQ_L$ ). The purpose of D-STATCOM is to provide reactive power to the load so that the electrical grid would only provide active power; therefore  $Q_D = -Q_L$ . D-STATCOM also requires active power to account for its losses, such losses should be provided by the electrical grid, then ( $S_D = P_D + jQ_D$ ). In this way, the electrical grid only supplies the active power required by the load and D-STATCOM operation

$$(S_G = P_L + P_D).$$

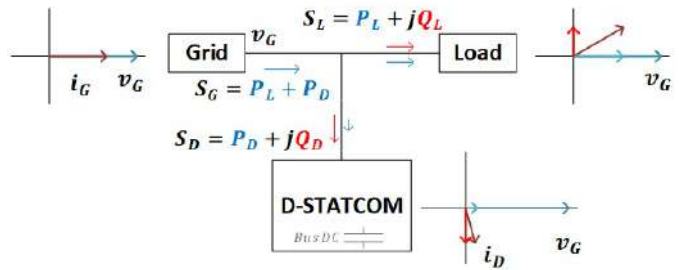

**Figure 5.** D-STATCOM compensation.  
Source: own.

The coupling inductors of D-STATCOM are in charge of filtering the current signals and coupling AC and DC voltages. Due to the switching nature of the VSC, D-STATCOM currents may present high harmonic content; so grid coupling inductors provide an output current that is similar to a pure sine wave. Appropriated design and implementation of grid coupling inductors is necessary to avoid harmonic contamination in the grid.

## 4. Experimental results

This section presents a comparison between compensation by means of capacitor banks and D-STATCOM. Tests were done in similar operative conditions for both devices in order to analyze the improvement of energy quality. Three aspects are analyzed in this stage: power factor correction, current waveform and new current harmonics generated by the compensation.

### 4.1 Load Characteristics

The load used for power factor correction is an induction motor with three inductors connected in series as indicated in Figure 6. The impedance of this arrangement is  $S_L = 3,08 + j9,33 \Omega$  per phase. The load is fed by a line-neutral voltage  $V_G = 21V$ .



**Figure 6.** Load for experimental tests. Source: own.

## 4.2. Compensation with Capacitor Bank

A single-phase AC capacitor is built with two electrolytic capacitors connected in series with opposite polarities as shown in Figure 7.



**Figure 7.** Single-phase AC capacitor.  
Source: own.

Figure 8 depicts the response of the AC capacitor when it is connected to the grid at the test voltage without load. It was found that the resulting current is displaced approximately 90° with respect to the voltage signal. Note that the current signal exhibits a high distortion in comparison to the feeding voltage. This evidence the non-linear characteristic of AC capacitors which increases the THD of the electrical system.

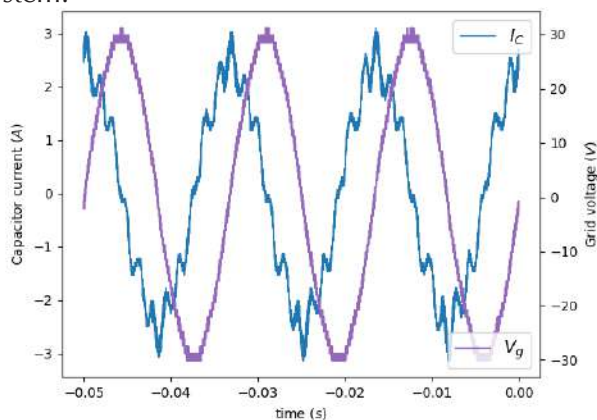

**Figure 8.** AC capacitor current. Source: own.

The three-phase capacitor bank used for the tests is built with three AC single-phase capacitors in delta connection. Figure 9 shows three-phase capacitor built to compensate reactive power. 1, 2 and 3 are arrangement of AC single-phase capacitors; each array has six capacitors connected in pairs to obtain three AC capacitors in parallel connection, adding up 18 electrolytic capacitors. Arrangements 1, 2 and 3 are connected to the load depicted in Figure 6 in order to show the effect of a compensation based on capacitor banks



**Figure 9.** AC three-phase capacitor.  
Source: own.

Test results of the compensation performed with the AC three-phase capacitor bank is shown in Figure 10. This figure has three columns; the first one illustrates the wave forms in time domain (Figure 10a); the second one depicts harmonics in frequency domain (Figure 10b); finally, the third one depicts the phasor diagram that is used to show power factor (Figure 10c). The first row of Figure 10 represents the electrical grid; in this case, the feeding voltage is  $V_G = 21V$  and it is the reference signal (gray signal of Figure 10a) for power factor compensation. The grid presents THD=1.83%, hence, grid voltage is not a pure sinusoidal wave. The phasor of the electrical grid is taken as the reference. The Second row of Figure 10 represents the load without compensation; in this case, the current wave is in backlog with respect to the reference wave in time domain. The load presents THD=0.77% in frequency domain. The phasor diagram presents an angle between current and voltage  $\alpha = -71.7^\circ$  which corresponds to  $\text{pf} = 0.312$  in backlog; this load does not comply with normative  $\text{pf} < 0.9$  and needs compensation. The third row of Figure 10 presents measures of AC three-phase capacitor under test voltage without load; in this case, current leads the reference by  $87.06^\circ$  ( $\text{pf} = 0.051$  leading); also, THD=12.2% evidences the non-linearity of the three-phase capacitors used to compensate reactive energy. The fourth row of Figure 10 corresponds to measures of load with compensation (load connected with three-phase capacitor); in this case, load and voltage waves are phased in time domain and  $\text{pf} = 0.997$  in the phasor

diagram; the load without compensation presented THD=0.77% and harmonics were increased up to THD=35.1% with the compensation using capacitors.

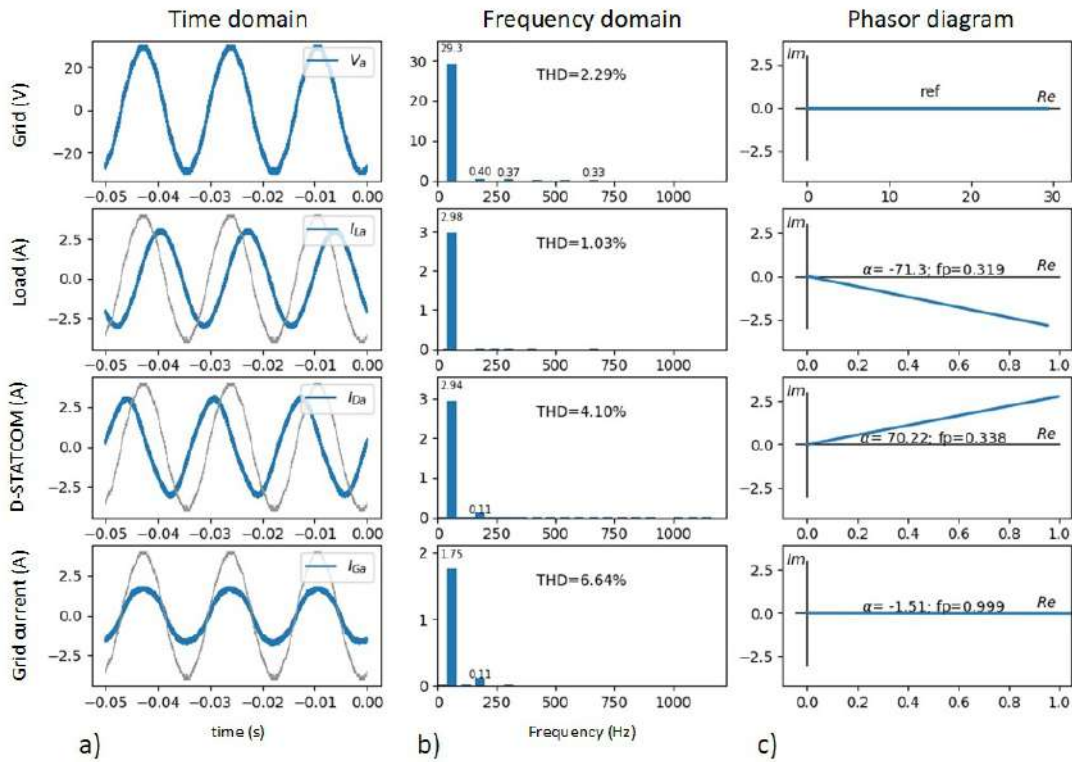

Figure 10b shows that THD of the grid current (load and capacitors) is higher than THD of the capacitors; however, harmonics amplitude of both are similar. Fundamental amplitudes are different due to the capacitive effect on reactive power compensation; nevertheless, there is not harmonic compensation and grid harmonic amplitudes remain approximately constant. THD is a harmonic measurement done by comparison between harmonics amplitude and fundamental amplitude as shown in equation 1. Therefore, capacitor THD is calculated with respect to  $I_f = I_c = 3.0A$  and grid THD with  $I_f = I_L = 1.0A$ . This measurement increases the THD value of the electrical grid and does not take into account that harmonics in both cases remain approximately constant.

$$THD = \frac{\sqrt{\sum_{n=2}^{\infty} I_n^2}}{I_f} \quad (1)$$

The test without load was repeated using a commercially available three-phase capacitor bank for reactive power compensation as depicted in

Figure 11. The capacitor illustrated in Figure 11a is able to compensate up to  $Q_c = 10kVAR$  with voltage  $V_c = 220V$  is used to compare with the response of the three-phase capacitor bank built with electrolytic capacitors. Current response is shown in Figure 11b, note that the distortion in the current wave is similar to the one illustrated in Figure 10b.

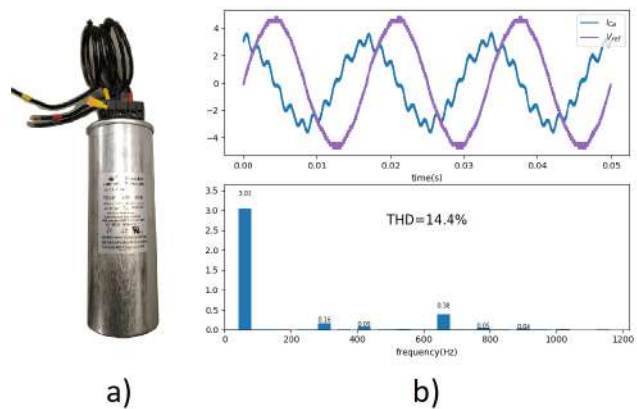

Figure 11. Capacitor for industrial reactive compensation.

## 4.2 Compensation with D-STATCOM

The **D-STATCOM** used for experimental test was developed in the laboratory of **GIMEL** research group at Universidad de Antioquia and is presented in Figure 12. The **D-STATCOM** was designed to compensate reactive power up to 15 kVA connected at 440 V with DC BUS at 850 Vdc in nominal operation conditions. Nevertheless, the feeding voltage of **D-STATCOM** was reduced up to  $V_G = 21V$  to do the tests presented in this paper.



**Figure 12.** D-STATCOM used for comparison.  
Source: own.

The results of compensation with D-STATCOM are presented in Figure 13. This figure has three columns. The first one illustrates the wave forms in time domain (Figure 13a); the second one, Figure

13b presents harmonics in frequency domain; and the third one Figure 13c presents the phasor diagram and power factor. The first row of Figure 13 represents the feeding source with  $V_G = 21V$  and  $THD=2.29\%$ . The second row of Figure 13 represents the load without compensation. In this case, the current wave is in backlog with respect to the reference wave in the time domain and  $THD=1.03\%$  in frequency domain. The load  $THD$  increased due to variation (increasing) of voltage  $THD$ . The Phasor diagram presents an angle between current and voltage  $\alpha = -71.3$  which corresponds to  $pf=0.319$  in backlog ( $pf < 0.9$ ). The third row of Figure 13 illustrates the D-STATCOM measures under test voltage without load operating as capacitor. In this case, the current leads the reference by  $70.22^\circ$  ( $pf=0.338$  leading) with  $THD=4.10\%$ ; D-STATCOM also introduces harmonics to the grid; nevertheless, these are minor than those introduced by the three-phase capacitor bank (66.4% approximately). The fourth row of Figure 13 corresponds to measures of load with compensation (load connected with D-STATCOM). In this case, load and voltage waves are phased in time domain and  $pf=0.999$  in the phasor diagram. The load without compensation had  $THD=1.03\%$  and harmonics were increased up to  $THD=6.64\%$  with the compensation using D-STATCOM. On the other hand, the three-phase capacitor bank presented  $THD=35.1\%$ , in comparison with D-STATCOM compensation, harmonics were reduced up to 81.08%.

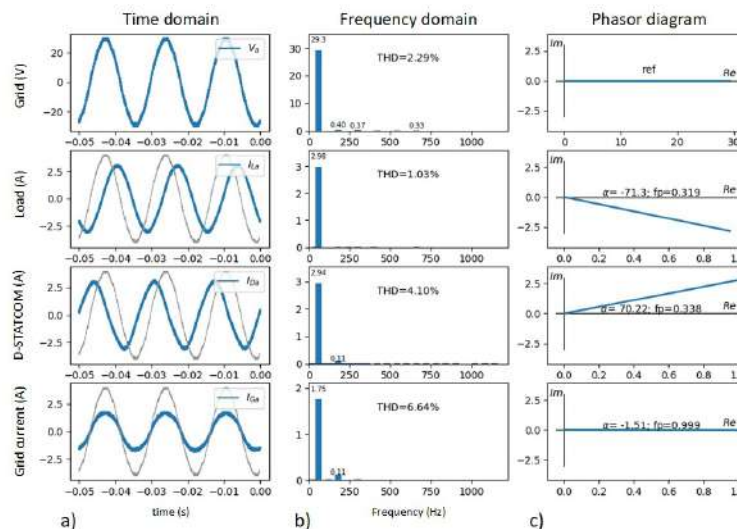

**Figure 13.** Compensation with D-STATCOM. Source: own.

Table 1 presents the main results obtained with the capacitor bank and D-STATCOM considering both with and without load. Experimental results without load show a major  $pf$  from D-STATCOM than that of the capacitor bank, and lower  $THD$  for D-STATCOM in comparison with the capacitor bank. Experimental results with load present a similar  $pf$  for both; nevertheless, the  $THD$  produced by the capacitor bank is up to 5 times greater than the  $THD$  obtained with the D-STATCOM, operating in the same conditions.

	Without load		With load	
	$PF$	$THD$	$PF$	$THD$
Capacitor Bank	0.051	12.2%	0.997	35.1%
D-STATCOM	0.338	4.10%	0.999	6.64%

**Table 1.** Main results comparison.  
Source: own.

## 5. Conclusions

This paper presented a comparison of reactive power compensation performed with capacitor banks and D-STATCOM. Both, D-STATCOM and a three-phase capacitor were set to compensate reactive energy up to  $pf=0.99$  in order to compare time and frequency responses in similar operating conditions. Experimental results showed a slightly higher  $pf$  with D-STATCOM when compared with the capacitors bank. It was also found that the  $THD$  with the capacitors was higher, even without load. The same power factor was reached with D-STATCOM; however, with a  $THD$  reduction of up to 81.08%. In this case,  $THD$  reduction is higher taking into account that D-STATCOM was feed with a major  $THD$  voltage.

Finally,  $THD$  results with power factor correction show that harmonics require another type of measurement. Generally,  $THD$  is calculated with respect to fundamental amplitude; nevertheless, compensation of reactive energy reduces this amplitude. Therefore, reduction on fundamental amplitudes causes an increase of  $THD$  even if harmonic magnitudes are not increased.

## Acknowledgments

The authors want to acknowledge “Proyecto de Sostenibilidad 2018” of Universidad de Antioquia for its support in the development of this work.

## References

- [1] M. L. Baughman and S. N. Siddiqi, “Real-time pricing of reactive power: theory and case study results,” *IEEE Trans. Power Syst.*, vol. 6, no. 1, pp. 23–29, Feb. 1991. <https://doi.org/10.1109/59.131043>
- [2] D. Andrews, M. T. Bishop, and J. F. Witte, “Harmonic measurements, analysis, and power factor correction in a modern steel manufacturing facility,” *IEEE Trans. Ind. Appl.*, vol. 32, no. 3, pp. 617–624, May 1996. <https://doi.org/10.1109/28.502174>
- [3] S. V. Berg, J. Adams, and B. Niekum, “Power factors and the efficient pricing and production of reactive power,” *Energy J.*, vol. 4, pp. 93–102, 1983.
- [4] H. Moreno, S. Plumel, and P. Bastard, “Assessing the value of reactive power service using OPF of reactive power,” in *2005 IEEE Russia Power Tech*, 2005, pp. 1–6. <https://doi.org/10.1109/ptc.2005.4524430>
- [5] Y. Varetsky and Z. Hanzelka, “Capacitor bank impact on harmonic filters operation in power supply system,” in *2009 10th International Conference on Electrical Power Quality and Utilisation*, 2009, pp. 1–4. <https://doi.org/10.1109/epqu.2009.5318826>
- [6] J. H. Han, M. Y. Jang, G. B. Lee, B. S. Jang, and Y. A. Kwon, “Improved Performance of Sensorless Induction Motor Using Reactive Power,” in *SICE Annual Conference 2007*, 2007, pp. 637–642. <https://doi.org/10.1109/sice.2007.4421060>
- [7] J. Benitez, “Application of capacitors for power factor correction of industrial electrical distribution systems,” in *[1992] Record of Conference Papers Industry Applications Society 39th Annual Petroleum and Chemical Industry Conference*, 1992, pp. 77–86.



<https://doi.org/10.1109/pcicon.1992.229323>

- [8] T. E. Grebe, "Application of distribution system capacitor banks and their impact on power quality," in *1995 Rural Electric Power Conference*, 1995, p. C3/1-C3/6. <https://doi.org/10.1109/repcon.1995.470933>
- [9] Z. Jianguo, S. Qiuye, Z. Huaguang, and Z. Yan, "Load balancing and reactive power compensation based on capacitor banks shunt compensation in low voltage distribution networks," in *Proceedings of the 31st Chinese Control Conference*, 2012, pp. 6681–6686.
- [10] M. A. S. Masoum, M. Ladjevardi, A. Jafarian, and E. F. Fuchs, "Optimal placement, replacement and sizing of capacitor Banks in distorted distribution networks by genetic algorithms," *IEEE Trans. Power Deliv.*, vol. 19, no. 4, pp. 1794–1801, Oct. 2004. <https://doi.org/10.1109/tpwrld.2004.835438>
- [11] E. F. Fuchs and M. A. S. Masoum, Eds., "Chapter 10 - Optimal Placement and Sizing of Shunt Capacitor Banks in the Presence of Harmonics," in *Power Quality in Power Systems and Electrical Machines*, Burlington: Academic Press, 2008, pp. 397–441. <https://doi.org/10.1016/b978-012369536-9.50011-5>
- [12] J. Dixon, L. Moran, J. Rodriguez, and R. Domke, "Reactive Power Compensation Technologies: State-of-the-Art Review," *Proc. IEEE*, vol. 93, no. 12, pp. 2144–2164, Dec. 2005. <https://doi.org/10.1109/jproc.2005.859937>
- [13] R. Redl and L. Balogh, "RMS, DC, peak, and harmonic currents in high-frequency power-factor correctors with capacitive energy storage," in *[Proceedings] APEC '92 Seventh Annual Applied Power Electronics Conference and Exposition*, 1992, pp. 533–540. <https://doi.org/10.1109/apec.1992.228364>
- [14] W. Xu, X. Liu, and Y. Liu, "Assessment of harmonic resonance potential for shunt capacitor applications," *Electr. Power Syst. Res.*, vol. 57, no. 2, pp. 97–104, 2001. [https://doi.org/10.1016/s0378-7796\(01\)00092-x](https://doi.org/10.1016/s0378-7796(01)00092-x)
- [15] J. Wang *et al.*, "An Improved Hybrid Modulation Method for the Single-Phase H6 Inverter With Reactive Power Compensation," *IEEE Trans. Power Electron.*, vol. 33, no. 9, pp. 7674–7683, Sep. 2018. <https://doi.org/10.1109/tpel.2017.2768572>
- [16] P. E. Melin *et al.*, "Study of Reactive Power Compensation Capabilities and LC Filter Design for a Three-Phase Current-Source STATCOM," in *2018 IEEE International Conference on Automation/XXIII Congress of the Chilean Association of Automatic Control (ICA-ACCA)*, 2018, pp. 1–5. <https://doi.org/10.1109/ica-acca.2018.8609717>
- [17] W. Rohouma, R. S. Balog, A. A. Peerzada, and M. M. Begovic, "Reactive Power Compensation of Time-Varying Load Using Capacitor-less D-STATCOM," in *2019 10th International Conference on Power Electronics and ECCE Asia (ICPE 2019 - ECCE Asia)*, 2019, pp. 2296–2301.
- [18] O. K. Shinde and V. R. S. V. B. Pulavarthi, "STATCOM converters and control: A review," in *2017 International Conference on Data Management, Analytics and Innovation (ICDMAI)*, 2017, pp. 145–151. <https://doi.org/10.1109/icdmai.2017.8073500>
- [19] A. K. Koshti and M. N. Rao, "A brief review on multilevel inverter topologies," in *2017 International Conference on Data Management, Analytics and Innovation (ICDMAI)*, 2017, pp. 187–193. <https://doi.org/10.1109/icdmai.2017.8073508>
- [20] P. Chaudhari *et al.*, "Design and implementation of STATCOM for reactive power compensation and voltage fluctuation mitigation in microgrid," in *2015 IEEE International Conference on Signal Processing, Informatics, Communication and Energy Systems (SPICES)*, 2015, pp. 1–5. <https://doi.org/10.1109/spices.2015.7091541>
- [21] M. T. L. Gayatri, Alivelu. M. Parimi, and A. V. Pavan Kumar, "A review of reactive power compensation techniques in microgrids," *Renew. Sustain. Energy Rev.*, vol. 81, pp. 1030–1036, Jan. 2018. <https://doi.org/10.1016/j.rser.2017.08.006>

- [22] E. T. McAdams, A. Lacknermeier, J. A. McLaughlin, D. Macken, and J. Jossinet, "The linear and non-linear electrical properties of the electrode-electrolyte interface," *Biosens. Bioelectron.*, vol. 10, no. 1, pp. 67–74, 1995. [https://doi.org/10.1016/0956-5663\(95\)96795-z](https://doi.org/10.1016/0956-5663(95)96795-z)
- [23] C. S. Lim, K. H. Teoh, C.-W. Liew, and S. Ramesh, "Capacitive behavior studies on electrical double layer capacitor using poly (vinyl alcohol)–lithium perchlorate based polymer electrolyte incorporated with TiO<sub>2</sub>," *Mater. Chem. Phys.*, vol. 143, no. 2, pp. 661 – 667, 2014. <https://doi.org/10.1016/j.matchemphys.2013.09.051>
- [24] L. A. Geddes, "Historical evolution of circuit models for the electrode-electrolyte interface," *Ann. Biomed. Eng.*, vol. 25, no. 1, p. 1, Jan. 1997.
- [25] C. C. Dobilier, "Aluminum Electrolytic Capacitor Application Guide". <https://www.cde.com/resources/catalogs/AEappGUIDE.pdf>
- [26] S. Lin *et al.*, "Robust Optimal Allocation of Decentralized Reactive Power Compensation in Three-Phase Four-Wire Low-Voltage Distribution Networks Considering the Uncertainty of Photovoltaic Generation," *Energies*, vol. 12, no. 13, p. 2479, Jan. 2019.
- [27] A. Angulo, F. Martínez, y G. López, "Almacenamiento de energía usando ultracondensadores en sistemas fotovoltaicos autónomos", *Visión electrónica*, vol. 11, no. 1, pp. 30-39, jun. 2017. <https://doi.org/10.14483/22484728.12875>