



Volume 109

2020

p-ISSN: 0209-3324

e-ISSN: 2450-1549

DOI: <https://doi.org/10.20858/sjsutst.2020.109.4>



Journal homepage: <http://sjsutst.polsl.pl>

Article citation information:

Jilek, P., Vrábek, L. Change of driver's response time depending on light source and brake light technology used. *Scientific Journal of Silesian University of Technology. Series Transport*. 2020, **109**, 45-53. ISSN: 0209-3324.

DOI: <https://doi.org/10.20858/sjsutst.2020.109.4>.

Petr JILEK¹, Luboš VRÁBEL²

CHANGE OF DRIVER'S RESPONSE TIME DEPENDING ON LIGHT SOURCE AND BRAKE LIGHT TECHNOLOGY USED

Summary. This paper deals with finding out the influence of the type of light source of car brake lights on the reaction time of the driver of the preceding vehicle. The driver's reaction time was measured in the form of pressing the brake pedal depending on the lighting of brake lights on the leading vehicle. The measurement evaluation consists of a comparison of the phase shift between the brake light signal of the first vehicle and the brake light signal of the second vehicle. The experimental measurement was performed for five people using the classic light bulb, afterwards, an LED light source for the brake lights of the first vehicle. The records confirmed that the driver's reaction time depends on many factors, with the source and intensity of the brake lights also playing an important role. Further, it affects the reaction time and the activity or inactivity of the rear sidelights. The reaction time of the driver of the preceding vehicle was extended with their activation.

Keywords: reaction time, car, brake light, safety

¹ Department of Transport Means and Diagnostics, Faculty of Transport Engineering, University of Pardubice, Studentská 95, 532 10 Pardubice, Czech Republic. Email petr.jilek@upce.cz.

ORCID: <https://orcid.org/0000-0002-3863-2252>

² Department of Transport Means and Diagnostics, Faculty of Transport Engineering, University of Pardubice, Studentská 95, 532 10 Pardubice, Czech Republic. Email st53142@student.upce.cz.

ORCID: <https://orcid.org/0000-0001-7371-407X>

1. INTRODUCTION

New materials and construction methods are constantly appearing in automotive technology. Therefore, their influence on the behaviour of drivers of the surrounding vehicles should be considered. This influence needs to be considered in a broader sense, concerning the happenings in the vehicle and around the vehicle. An important element of active road vehicle safety is lighting. The driver should be able to see and orientate himself/herself in this way in road traffic. However, been seen is an equally important aspect. It is especially true in areas where there is an emergency, such as a change of direction or a speed reduction. Thus, the visibility of turn indicators and brake lights is an important aspect. A large part of all accidents is caused by failure to maintain a safe distance, when the driver is not able to react in time and correctly to the situation in road traffic. From the point of view of road safety, it is necessary to focus on measures to ensure that a safe distance is maintained and that the driver's reaction time is shortened [5,6,8,9,11-14,17].

The shape of the headlights and taillights is a powerful tool in today's vehicles when dealing with vehicle designs. With new lighting technologies, taillights are no longer simple in design but complex with 3D shapes. Therefore, the brake lights can be part of the taillights and still fulfil their functions.

2. MATERIALS AND METHODS

The driver's reaction time is determined by his/her physiological nature as a living organism. Therefore, it cannot be infinitely short. Its length is determined by moral integrity and the current psychological disposition; possibly by any narcotic and addictive substances in the human body [9,12,15]. The reaction time can be considered as the time required for the driver's biological system to respond to a stimulus in the driver's field of vision, even in cases where the stimulus is sudden and unexpected.

The optical response is given by the moment of perceiving an object that is outside the driver's field of vision. Visual perception is essential when driving. The driver obtains about 90% of all information through it. The optical response time ranges from 0 to 0.7 seconds and depends on the magnitude of the angular deviation of the stimulus from the driver's line of sight [3,16].

Mental response is defined as the time interval required by the driver to recognise and evaluate the stimulus. This is a variable time depending on the complexity of the situation, the ingestion of additives and psychotropic substances and fatigue. Moreover, the reaction is greatly affected positively by experience and expecting a possible situation. A situation with more than one solution has a negative effect. Here, the driver evaluates the situation and decides what action to take according to the stimuli received. The mental reaction duration is 0.2-0.6 seconds [4,12,22].

Muscular response is similarly determined by the biological nature of the human body and is the body's response to a detected stimulus. It is significantly affected by training and movement trajectory. It is the time interval wherein the driver between the end of the mental reaction until the moment, in our case, when the driver touches the brake pedal. The muscle reaction interval is approximately 0.2 seconds [4,12].

The division of the reaction time between the car and the driver can be realised according to many aspects, which are elaborated in more detail in [2,10,18]. From the viewpoint of road safety, great attention should be paid to the driver's reaction time. Any increase in reaction

time is undesirable and increases the overall distance required to stop the car safely; this is the reason assistance systems are used. Assistance systems in the form of adaptive cruise control (ACC), night vision systems [4], and panic braking systems [3,18] are becoming increasingly popular in modern vehicles as elements reducing driver's reaction time.

2.1. Experimental measurements

We performed experimental measurements on stationary vehicles to minimise the influence of disturbing environmental stimuli. These were located in the covered premises of the laboratories of the Educational and Research Centre in Transport of the University of Pardubice. The leading vehicle was visible from the other vehicle. The illumination of the measurement point was constant. The current conditions from the implementation of the experiment are evident in Fig. 1. The Škoda Rapid and Škoda Superb were selected for the experiment. The Škoda Rapid was the leading vehicle that initiated the reaction stimulus.



Fig. 1. Experimental measurements

2.2. Measured data records

Brake signal BS - the leading edge is the carrier of information about the beginning of braking in the test subject. This is a rectangular signal, which with its falling edge defines the end of the process of acting on the brake pedal by the test subject.

Optical signal OS - is defined by the beginning of the action on the brake pedal in the leading vehicle. The leading vehicle is a car to which the test subject in the other vehicle responds to when its brake lights come on.

Driver's reaction time DRT - it was calculated from the mutual phase shift between the measured signals according to Equation (1) from the measured brake and optical signal. Each signal corresponds to a specific time interval.

$$RDR_i = BS_i(t) - OS_i(t) \quad (1)$$

When the leading vehicle's brake pedal is pressed, the brake light is activated. This is a simple optical stimulus for the test subject. Measuring control panel (Fig. 2) (detailed

specifications are given in [7,10] records the optical signal *OS* of the leading vehicle by a step change of the input parameter. When the brake pedal is pressed in the other vehicle, the brake light of the vehicle with the test subject is activated and the measuring relay is open at the same time. The measuring control panel records the step change in the input parameter. Thus, the brake signal *BS* of the vehicle with the test subject is obtained.

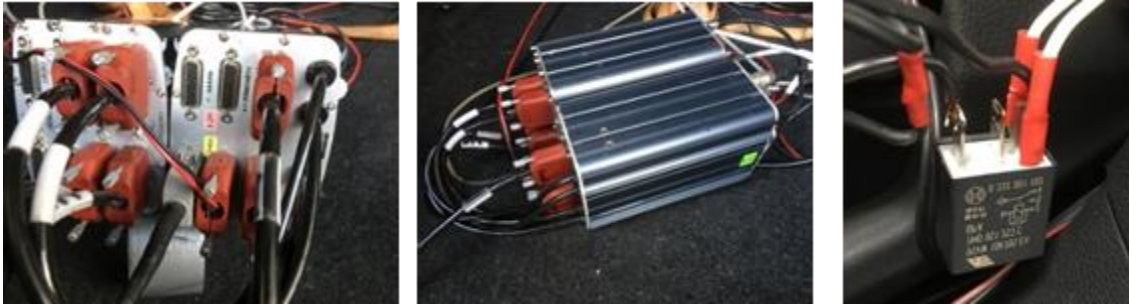

Fig. 2. Arrangement of the measuring system

Possible logic levels of the evaluated signals are schematically shown in Fig. 3.

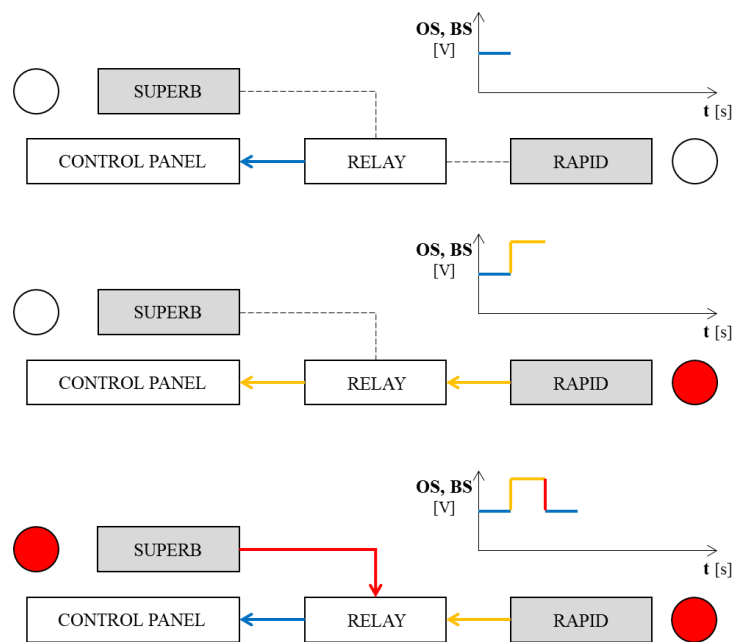

Fig. 3. Logic of measured signals

We chose the original P 21/4 W bulb as the first luminous flux source. An LED source was used as an alternative. It was without the necessary homologation for operation on roads [1,21].

We determined the interval of full light of the light source with the help of video recording. These are ten measurements for a conventional light source and then the same number of measurements for an LED. We evaluated the required rise of the luminous flux by phasing the record [15,19,20]. The last frame for the beginning of the lighting where the luminous flux is zero was selected. We chose a frame where there was not an increase in the intensity of the luminous flux in the following vehicle as the full light of the light source. It is clear from the measurement results that the LED light source reaches full light in 0.033 s and

the conventional light bulb in 0.2 s, as shown in Fig. 4. On a theoretical level, the driver's reaction time when using an LED light source should be 0.166 s shorter than when using a conventional light bulb.

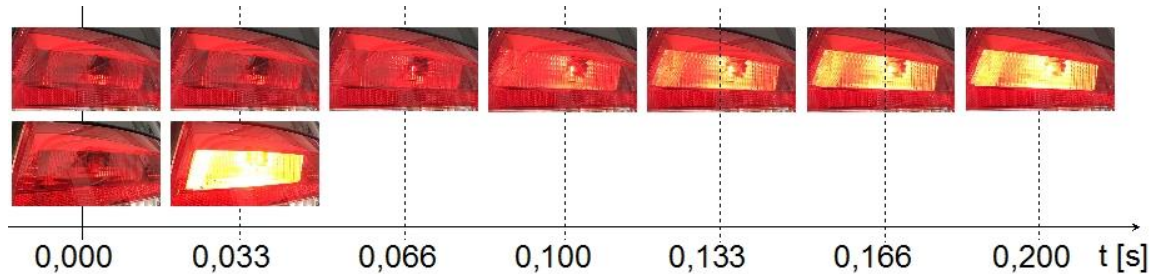

Fig. 4. Increase in luminous flux, conventional light bulb / LED

2.3 Conditions for the experiment implementation

The reaction time was measured in the laboratory under artificial lighting. Four men and one woman participated in the experimental measurement. The subjects were in the age range of 27-44 years. The leading vehicle was in front of the second vehicle with the test subject at a distance of 2.5 metres. The system of rear brake lights of the leading vehicle was chosen as the optical stimulus. A central brake lamp with an LED source of luminous flux would adversely affect the nature of the measurement. Therefore, it was deactivated in the leading vehicle. The leading vehicle turned on the brake lights at random intervals for a set period. This created reaction stimuli for the test subject in the second vehicle. The task of the test subjects was to press and hold the accelerator pedal in the maximum position. This eliminated the readiness of the right foot on the brake pedal. The test subject had to press the brake pedal immediately noticing the random lighting of the driving vehicle's brake lights.

We experimented with two options. The difference is that the rear sidelights were switched on in the second case compared to the first set of measurements. Thus, the test stimulus was less contrasting than with the sidelights off.

3. RESULTS AND DISCUSSION

To determine the reaction time in the test subjects, we used a median \tilde{x} calculated according to Equation 2.

$$\tilde{x} = \frac{x_{(\frac{N}{2})} + x_{(\frac{N}{2}+1)}}{2}, \quad (2)$$

where:

N – number of all values,

$x_{(\frac{N}{2})}$ – the first value with an index determining the position in an increasing sequence of values,

$x_{(\frac{N}{2}+1)}$ – the second value with an index determining the position in an increasing sequence of values.

The resulting reaction time for the group of test subjects is given in Table 1.

Table. 1

Reaction time of a group of test subjects

Reaction time [s]	Light source - bulb	Light source - LED	Difference
Rear sidelights off	0.592	0.560	0.032
Rear sidelights on	0.608	0.572	0.036

A graphical representation of the measurement results is shown in Fig. 5, 6 and 7.

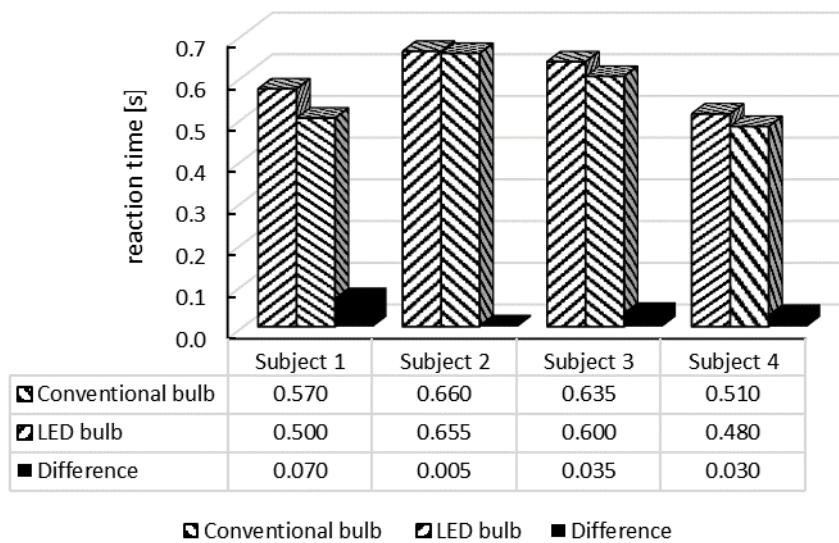

Fig. 5. Partial results for the sidelights off

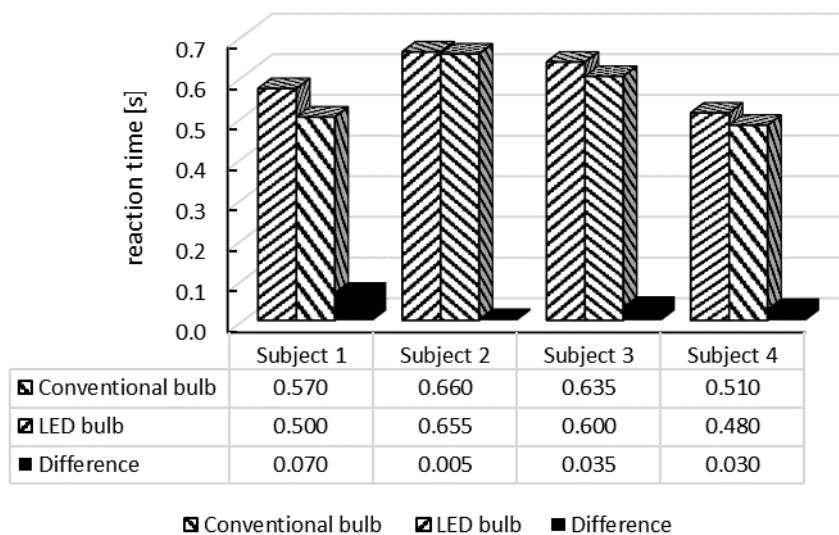

Fig. 6. Partial results for the sidelights on

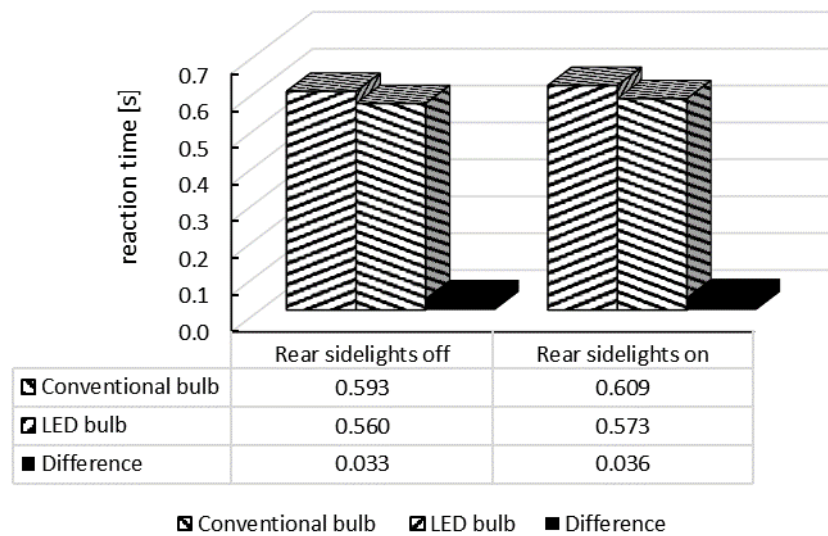

Fig. 7. Total results

The largest reduction in reaction time in an individual was 0.07 s, which corresponds to 42.2% of the expected reduction in driver's response time. The average reduction in the reaction time of the group was 0.03 s, which corresponds to 20.7% of the expected reduction in the driver's reaction time. Based on the results of the experimental measurements, it can be assumed that the human eye responds to the conventional light bulb during its turning on, and not only to its full light. The experiment results did not show that the reaction time would be shortened by the expected 0.17 seconds in the case of replacing a conventional light bulb with an LED light bulb.

It is evident from the measured results that the driver driving behind the vehicle with an LED light source installed will start braking at a speed of 130 km.h^{-1} 1.24 m earlier on average than when using a conventional light source. The braking distance will be shortened by up to 2.5 metres in the case of the measured maximum in a person. There is a presumption that the use of a homologated source, which has a higher luminous flux than the non-homologated LED source used by us, will further shorten the driver's reaction time.

4. CONCLUSION

It is evident from the experimental measurements that the change in the reaction time occurred when using an LED light source. The length of the reaction time was also affected by the rear sidelights being on or off. When the brake lights are switched on while the sidelights are on at the same time, the trigger impulse is less contrasting, causing the reaction time to be extended. When using an LED light source, the reaction time was shortened compared to a conventional light source. Since the tested driver expected a test stimulus in the form of switching on the brake lights of the leading vehicle in the moment, the reaction time of the driver's mental reaction is reduced to a minimum. Because the same testing conditions were for all experimental measurements and the results are processed on a relative level and not an absolute one, this simplification does not invalidate the experimental results.

To express an exact conclusion based on the experiment results, it is necessary to perform experimental measurements on a representative and statistically significant sample of drivers and in various ambient conditions, or in an experimental dynamic (driving) test. Subsequently, this is a subject for further research for the authors.

References

1. Balal Nezah, Yael Balal, Yair Richter, Yosef Pinhasi. 2020. „Detection of Low RCS Supersonic Flying Targets with a High-Resolution MMW Radar”. *Sensors* 20(11): 3284. DOI: <https://doi.org/10.3390/s20113284>.
2. Borecký Petr. 2018. *Reakční čas řidičů*. [In Czech: *Drivers' reaction time*]. Thesis. Praha: České vysoké učení technické.
3. Bradáč A. 1997. *Soudní inženýrství*. [In Czech: *Forensic engineering*]. Brno: Akademické nakladatelství CERM.
4. Cyganek Boguslaw, Slawomir Gruszczynski. 2014. „Hybrid computer vision system for drivers' eye recognition and fatigue monitoring”. *Neurocomputing* 126: 78-94.
5. Czech Piotr. 2017. „Physically disabled pedestrians - road users in terms of road accidents”. *Lecture Notes in Networks and Systems* 2: 157-165. DOI: 10.1007/978-3-319-43985-3_14. In: Edited by: Macioszek E., Sierpinski G. *Contemporary challenges of transport systems and traffic engineering*. 13th Scientific and Technical Conference on Transport Systems. Theory and Practice (TSTP). Katowice, SEP 19-21, 2016.
6. Dabbour Essam, Abdallah Badran. 2020. „Understanding how drivers are injured in rear-end collisions”. *European Transport \ Trasporti Europei* 77 n. 1. ISSN: 1825-3997.
7. Devault L. Travis, W. Thomas Seamans, F. Bradley Blackwell. 2020. „Frontal vehicle illumination via rear-facing lighting reduces potential for collisions with white-tailed deer”. *Ecosphere* 11(7) e03187. DOI: <https://doi.org/10.1002/ecs2.3187>.
8. Distefano Natalia, Salvatore Leonardi, Giulia Pulvirenti, Richard Romano, Natasha Merat, Erwin Boer, Ellie Woolridge. 2020. „Physiological and driving behaviour changes associated to different road intersections”. *European Transport \ Trasporti Europei* 77 n. 4. ISSN: 1825-3997.
9. Etinge Ariel, Nezah Balal, Boris Litvak, t MosheEina, Boris Kapilevich, Yosef Pinhasi. 2014. „Non-Imaging MM-Wave FMCW Sensor for Pedestrian Detection”. *IEEE Sensors Journal* 14(4): 1232-1237. DOI: <https://doi.org/10.1109/JSEN.2013.2293534>.
10. Jilek Petr. 2018. *Vývoj systému pro ověřování jízdní stability silničního vozidla ve vztahu k adhezním podmínkám*. [In Czech: *Development of a system for verifying the driving stability of a road vehicle in relation to adhesion conditions*]. Dissertation. Pardubice: Univerzita Pardubice.
11. Jurecki Rafal S. 2020. „Analysis of Road Safety in Poland after Accession to the European Union”. *Communications – Scientific Letters of the University of Zilina (Komunikacie)* 22(2): 60-67. ISSN: 1335-4205.
12. Kleprlík Jaroslav. 2020. „Opatření pro zajištění účinného a správného brzdění silničních vozidel”. *Perner's Contacts* 11(1): 68-81.
13. Montalva Sonia, Carlos Muñoz Juan, Ricardo Paredes. 2010. „Assignment of work shifts to public transit drivers based on stated preferences”. *Public Transport* 2: 199-218.

14. Nowosielski Adam, Krzysztof Malecki, Pawel Forczmanski, Anton Smolinski, Kazimierz Krzywicki. 2020. „Embedded Night-Vision System for Pedestrian Detection“. *IEEE Sensors Journal* 20(16): 9293-9304. DOI: <https://doi.org/10.1109/jsen.2020.2986855>.
15. Osmančík Radek. 2017. *Analýza změny reakční doby vlivem působení vnějších a vnitřních vlivů organismu*. [In Czech: *Analysis of the change in reaction time due to the influence of external and internal influences of the organism*]. Thesis. VŠB – Technická univerzita.
16. Patella Sergio Maria, Simone Sportiello, Stefano Carrese, Francesco Bella, Francesco Asdrubali. 2020. „The effect of a LED lighting crosswalk on pedestrian safety: Some experimental results“. *Safety* 6(2). Article number 20. DOI: <https://doi.org/10.3390/safety6020020>.
17. Prentkovskis Olegas, Edgar Sokolovskij, Vilius Bartulis. 2010. “Investigating traffic accidents: a collision of two motor vehicles”. *Transport* 25(2): 105-115.
18. Štěrbá Pavel. 2013. *Elektronika a elektrotechnika motorových vozidel: seřizování, diagnostika závad a chybové kódy OBD*. [In Czech: *Electronics and electrical engineering of motor vehicles: adjustment, fault diagnosis and OBD fault codes*]. CPress.
19. Vlk František. 2006. *Automobilová elektronika*. [In Czech: *Automobilová elektronika*]. Brno: Nakladatelství a vydavatelství Vlk.
20. You-Sun Won, Chung-Hwan Kim, Sang-Gug Lee. 2015. „Range Resolution Improvement of a 24 GHz ISM Band Pulse Radar – A Feasibility Study“. *IEEE Sensors Journal* 15(12): 7142-7149. DOI: <https://doi.org/10.1109/JSEN.2015.2469154>.
21. Zhangjing Wang, Yu Wu, Qingqing Niu. 2019. „Multi-Sensor Fusion in Automated Driving: A Survey“. *Access IEEE* 8: 2847-2868. DOI: <https://doi.org/10.1109/ACCESS.2019.2962554>.
22. Zikmund Tomáš. 2006. *Dynamika podvozkových částí silničních vozidel*. [In Czech: *Dynamics of chassis parts of road vehicles*]. Dissertation. Pardubice: Univerzita Pardubice.

Received 02.08.2020; accepted in revised form 30.10.2020



Scientific Journal of Silesian University of Technology. Series Transport is licensed under a Creative Commons Attribution 4.0 International License