

A NOVEL METHOD FOR THE GROUP CHARACTERISTICS ANALYSIS OF YELLOW FEATHER BROILERS UNDER THE HEAT STRESS BASED ON OBJECT DETECTION AND TRANSFER LEARNING

基于目标检测和迁移学习的黄羽鸡在热应激下群体特征分析

Anlan Ding ¹⁾, Xuhui Zhang, Xiuguo Zou ^{*}), Yan Qian, Heyang Yao, Shikai Zhang, Yuning Wei ¹

¹⁾ College of Engineering, Nanjing Agricultural University / China;

Tel: +862558606585; E-mail: xiuguozou@gmail.com

DOI: 10.35633/INMATEH-59-06

Keywords: broiler, heat stress, deep learning, liveness analysis

ABSTRACT

Temperature is a very important factor in the breeding of yellow feather broilers. Researching the group behaviour of yellow feather broilers under heat stress can help farmers take the corresponding measures to reduce the heat stress of broilers and improve production performance. In this paper, several traditional methods have been employed to detect and locate the broilers. These methods are highly interfered by the background whose colour is similar to broilers, thereby making it difficult to accurately locate the broilers. Meanwhile, although the algorithm YOLOv3 can precisely segment and locate the broilers, it has the disadvantages of incomplete detection and low detection confidence rate. Finally, this paper applies the neural architecture search and transfer learning to train the pre-processed training set, and obtains a detection model with a recognition accuracy of 83%. Then this model is used to process the images under heat stress at every 30 s so as to obtain the distribution of the broilers at each moment. Based on the results, the liveness and distribution characteristics of the broilers are analyzed. The analysis results show that when heat stress occurs, the broilers mainly gather at the vent; that when the temperature further rises above 30°C, the proportion of broilers at the vent increases from 53.3% to 67.3% on average; and that the activity index of the broilers decreases by 22.54% within an average of 3 h after the temperature rises to 30°C.

摘要

在黄羽鸡生产养殖中，温度是一个非常重要的因素。研究热应激下黄羽鸡的群体行为可以帮助养殖户更深入地了解黄羽鸡在热应激下的反应，从而采取相应的措施减少鸡的热应激现象，提高鸡的生产性能。本文首先研究了几种对黄羽鸡检测的方法，根据检测的结果无法进行下一步的精确分析，而基于 Darknet-53 的 YOLOv3 算法则存在识别不精准的问题。最后本文利用 Neural Architecture Search 和 Transfer Learning 对预处理后的训练集进行训练，获得了识别准确率为 83% 的检测模型。基于此模型分析鸡群活跃度和分布特征，结果表明，鸡群在温度上升至 30°C 之后平均 3 小时内活跃度指数会降低 22.54%。在分布上，热应激发生时鸡只主要聚集在通风口处，当温度进一步升高至 30°C 以上时，通风口处鸡的比例平均由 53.3% 上升至 67.3%。

INTRODUCTION

Heat stress is one of the most important environmental stressors challenging poultry production worldwide. Nowadays, broiler breeding industry has developed into large-scale and specialized mode. As the number of broilers increases, the heat stress phenomenon of broilers will become more prominent in summer (Lara L.J., 2013). The physiological responses of broilers under heat stress divert energy from efficient production and increase the morbidity and mortality (Shakeri M., 2018). The negative effects of heat stress on yellow feather broilers include reduced growth and egg production, as well as decreased poultry and egg quality and safety (Goo D., 2019). Therefore, breeders must pay attention to the heat stress of broilers and take preventive measures. In most areas of China, especially southern China, the continuous high temperature and humid heat in summer easily bring heat stress to yellow feather broilers, which seriously affect the growth of broilers.

Many researchers have investigated the effects of heat stress on poultry productivity and immune response. However, it is actually scarce on our knowledge of the basic mechanism related to the reported

¹ Anlan Ding, Mr.; Xuhui Zhang, Mr.; Xiuguo Zou, Assoc. Prof. Ph.D.; Yan Qian, Assoc. Prof. Ph.D.; Heyang Yao, MAE. Stud.; Shikai Zhang, MAE. Stud.; Yuning Wei, MAE. Stud.

effects and the behaviour of poultry under heat stress. The analysis of the effects of heat stress on broilers mostly focuses on the physiological characteristics of broiler, but seldom on the group behaviour of the whole broiler flock (Habashy W.S., 2017; Huang S., 2018). The important information contained in animal behaviour is an intuitive index to evaluate animal welfare, which can enable producers to better manage livestock and poultry production (Dawkins M.S., 2012). Therefore, it is of great significance to investigate the behaviour of broilers under heat stress.

In order to research the group behaviour of broilers, it is necessary to separate broilers from the background before further analysis. However, yellow feather broilers are raised in groups and have the same individual appearance, which makes it very difficult to detect and separate them individually. Moreover, the non-rigid bodies of yellow feather broilers make it more difficult to research their behaviour than large animals' behaviour (Liu L., 2014). In recent years, some scholars are also trying to automatically identify the individual or group behaviours of laying hens or broilers through image processing technology (Aydin A., 2010; Leroy T., 2006). However, due to the unobvious contrast between livestock and poultry, and their backgrounds, background changes and uneven illumination, the extraction of broilers using traditional digital image processing technology would make errors, thus affecting the accuracy of analysis (Lao F., 2017).

About the target extraction, a series of traditional algorithms (e.g. background difference method) and deep learning algorithms (e.g. RCNN, Fast RCNN, Faster RCNN and YOLO) have been proposed (Girshick R., 2014; Ren S., 2015; Redmon J., 2016). However, most of these algorithms are usually applied to the target extraction of pedestrians, vehicles and ships, etc., and rarely applied to the detection of small targets such as poultry (Wang D., 2018; Zhang H., 2019). In this paper, some traditional algorithms and deep learning algorithms are used to extract yellow feather broilers. Through the analysis and comparison of the extraction results, the final detection model is selected.

Based on the accurate extraction of broilers by the detection model, the distribution index and activity of broilers are analyzed. At present, there is little research on calculating broiler distribution index and activity. Lao Tree Peony et al (Lao F., 2017) calculated the distribution index and activity of laying hens based on the pixels occupied by laying hens. In terms of distribution index, as the size of broiler is not always the same during the experiment, it is difficult to completely extract the pixels occupied by broilers, and the phenomenon of mutual overlap often occurs, which leads to large errors in calculating distribution index. Therefore, this paper proposes a method of using the number ratio of broiler as an index of distribution index based on the acquired images and the target detection algorithm. In terms of activity analysis, this paper makes some improvements to the original pixel method, where pixel variables are converted into area variables, and the activity is calculated based on the dislocation area of the regions occupied by yellow feather broilers in the previous image and in the next image. The experiment shows satisfactory results, which provides a reference for the prevention of heat stress of yellow feather broilers.

MATERIALS AND METHODS

Data Acquisition

The broiler house used in this paper has two chambers designed by cotton-coated coloured steel plates. Each broiler chamber has a width of 1.9 m, a length of 2.9 m, a height of 1.88 m on the western side and a height of 1.77 m on the eastern side. The roof is sloped to facilitate rainwater drainage. Inside the broiler chamber, we mounted a temperature and humidity monitoring system, a ventilation system and a video monitoring system. The floor is paved with wood panels and ventilation pipes are laid below (Zhang S., 2019; Yao H. 2018). The three-dimensional chamber model was established by SolidWorks and is shown in Figure 1.

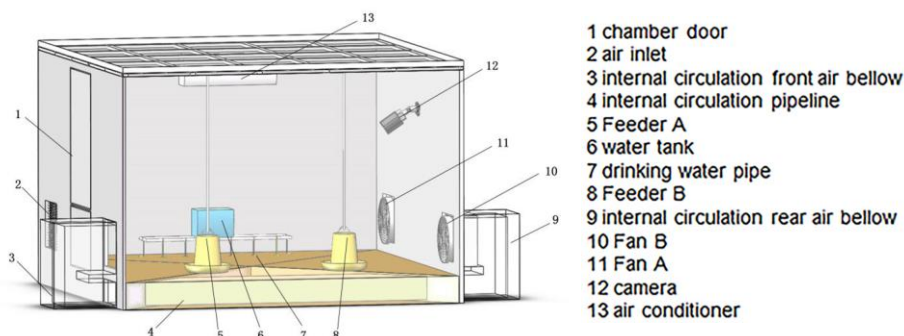

Fig. 1 - The three-dimensional chamber model was established by SolidWorks

The data acquisition lasted from July 20th to August 8th, 2018. The cameras worked all day and the data were saved on the hard disk of the host computer.

Broiler Target Detection Method

- **Background Subtraction Algorithm**

The background subtraction algorithm is to subtract each current image from the background image stored in advance or acquired in real time, and calculate the area deviating from the background beyond a certain threshold value. Therefore, the target object is extracted. The specific operation flow is shown in Figure 2 (Zhao K., 2015).

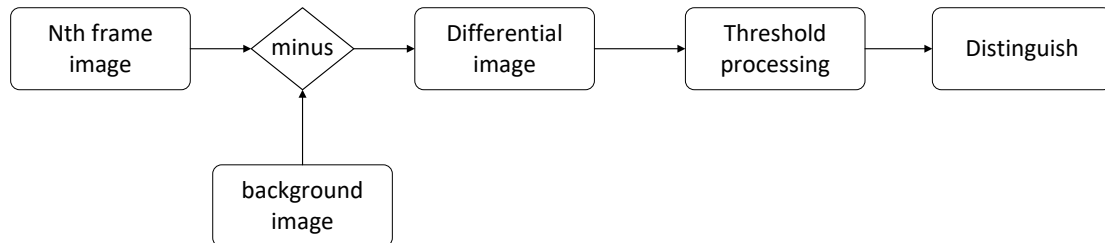

Fig. 2 - The specific operation flow of background subtraction algorithm

Let the n^{th} image and the background image be $f_n(x, y)$ and $f(x, y)$, respectively, where x and y represent the coordinates of a pixel (x, y) . The gray values of the corresponding pixels of the two frames of images are subtracted according to Equation (1), and their absolute values are used to obtain the differential image D_n (Braham M., 2016; Yang J., 2012).

$$D_n(x, y) = |f_n(x, y) - f(x, y)| \quad (1)$$

A threshold value T (manual test and selection based on the acquired image, and $T = 135$ in this experiment) is set to binarize the image according to Equation (2) and a binary image $R_n(x, y)$ is obtained. Among them, the point with a gray level of 255 is the front scenic spot, and the point with a gray level of 0 is the background point. The processing result is shown in Figure 3(c).

$$R_n(x, y) = \begin{cases} 255, & D_n(x, y) > T \\ 0, & \text{else} \end{cases} \quad (2)$$

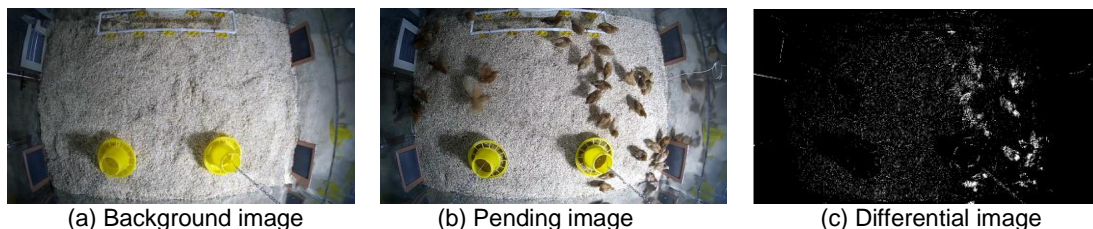

Fig. 3 - The processing result of background subtraction algorithm

As shown in Figure 3, the extraction results by background subtraction algorithm are not satisfactory, mainly because the background environment is affected by illumination, camera shaking, and the variations of the background images at different moments. Moreover, the activities of yellow feather broilers change the positions of troughs and other objects in the background image, and their shadows increase the area of foreground, which reduces the extraction effect.

- **Threshold Segmentation based on RGB Space**

RGB colour model is based on the principle of three primary colours of human vision and is the most basic colour model. It uses the three primary colours (red, green and blue) with different proportions to produce a variety of coloured images.

Each *RGB* image can be represented as a three-dimensional matrix of $m*n*3$, and the colour of each pixel in the image is obtained from the values of the *RGB*'s three components in the interval $[0, 255]$. Therefore, *RGB*'s three components can form $256*256*256$ colours in total.

Colour extraction uses the difference of RGB's three-component values between each pixel to set a threshold and extract the target object. Before threshold segmentation, a colour histogram is drawn, as shown in Figure 4.



Fig. 4 - The pre-processing of colour component

The appropriate threshold value T is manually selected according to the colour histogram. In this experiment, we take $T = 5$, and the image is processed according to Equation (3) to obtain the binary image Rn (Dong X., 2009).

$$Rn(m,n,d) = \begin{cases} Rn(m,n,d), & Rn(m,n,1) - Rn(m,n,2) > T \\ 255, & \text{else} \end{cases} \quad (3)$$

The extraction result is shown in Figure 5.

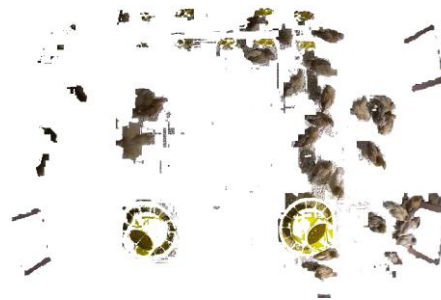

Fig. 5 - The extraction result obtained using colour components

As shown in Figure 5, most of the broilers are extracted. However, the colour of the food trough is similar to that of broilers, which leads to poor extraction effect. If the food trough in the image is removed through pre-processing, the broilers foraging around the food trough would also be removed. Besides, some broilers in the image are hidden by shadows. As a result, the corresponding pixels fail to reach the threshold value, resulting in poor extraction. Although the colour extraction method is better than the background difference method, there are still some deficiencies.

• **Colour Clustering based on YCbCr Space**

YCbCr is another common colour model, where Y is the brightness of colour in this colour space, Cb and Cr represent the chromaticity of blue and red, respectively. As YCbCr colour space has good clustering effect on the colour of yellow feather broilers, and RGB colour space is greatly affected by brightness, RGB colour space can be converted into YCbCr colour space, as expressed by (Patvardhan C., 2017; Shaik K.B., 2015).

$$\begin{bmatrix} Y \\ Cb \\ Cr \\ 1 \end{bmatrix} = \begin{bmatrix} 0.2990 & 0.5870 & 0.140 & 0 \\ -0.1687 & -0.3313 & 0.5000 & 128 \\ 0.5000 & -0.4187 & -0.0813 & 128 \\ 0 & 0 & 0 & 0 \end{bmatrix} \bullet \begin{bmatrix} R \\ G \\ B \\ 1 \end{bmatrix} \quad (4)$$

Statistical experiments show that the aggregation of feather colour space on YCrCb is mainly concentrated around $Cb=150$. Based on Equation (5), the coloured broiler chamber image is processed, and the binary image of the broiler is obtained through colour clustering (Das A., 2016; Prasetyo E., 2017).

$$\begin{cases} (R, G, B) = (255, 255, 255) & \text{if } Cr \in (80, 120) \text{ and } Cb \in (133, 165) \\ (R, G, B) = (0, 0, 0) & \text{if } Cr \notin (80, 120) \text{ or } Cb \notin (133, 165) \end{cases} \quad (5)$$

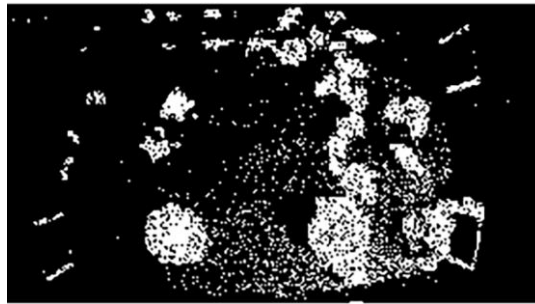

Fig. 6 - Binary image after colour clustering

As can be seen from Figure 6, the results of colour clustering are strongly interfered by illumination, causing false detection and missing detection in the lower right corner and the upper left corner. Moreover, some colours similar to the feather colour of yellow feather broilers are also detected and processed, such as troughs and padding, causing interference in the image.

- **YOLOv3 Object Detection Algorithm**

YOLO algorithm uses the whole image as the input of a simple end-to-end network, and adopts the method of regression to detect and classify the coordinate frames, thus greatly accelerating the training process. In addition, YOLOv3 designs a better basic classification network and classifier darknet-53 based on YOLOv2, which greatly improves the prediction accuracy and speed of YOLOv3 compared with other models (Redmon J., 2017).

Before using YOLOv3 to train model, the broilers are marked and XML files are created. The main annotation software includes yolo_mark, Sloth, Annotorious, RectLabel and Labellmg, etc. Finally, Labellmg is adopted as the image annotation tool, as it is simple to operate and can directly generate XML files.

Labellmg was used to mark up 100 images and generate XML files. On the NVIDIA GTX 1080ti graphics card with 11GB of memory, the images were trained based on the Keras framework. The batch size was set to 2 and the iteration was performed for 30 times. When the loss of the training set dropped to 109.1595, the loss of the validation set dropped to 156.1932. Then the loss no longer dropped significantly, and the training ended. Some of the detection results are shown in Figure 7.

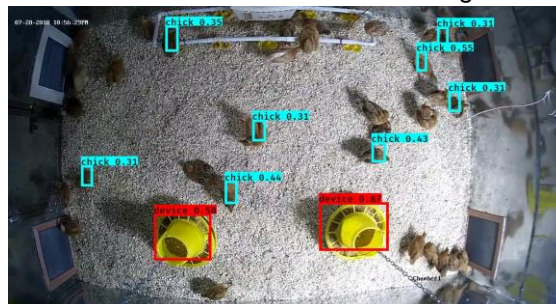

Fig. 7 - Detection results of YOLOv3 algorithm

As can be seen from Figure 8, the model only detected two troughs and eight broilers. The frame was generally small and the confidence rate was less than 60%. Due to the use of a single light source, the image brightness was not uniform, and the broiler presented shadows of different sizes, which interfered with the training of the model, resulting in poor performance of YOLOv3 on the dataset.

- **NAS and Transfer Learning**

As the above algorithms have the problems of low detection accuracy and incomplete detection, this paper uses the PaddlePaddle framework, the neural architecture search and transfer learning to train the dataset.

(1) Neural Architecture Search

In order to improve the accuracy of the detection model, this paper uses NAS to search the neural network structure. During the training, multiple model structures and different pieces of training of hyperparameter were initiated, and the corresponding algorithm was used to screen the final model, thus obtaining the optimal model effect (Zoph B., 2017).

(2) Transfer Learning

The model was pre-trained on some large-scale datasets, and then the knowledge learned from applying to the yellow feather broiler datasets, which greatly improved the efficiency and accuracy. Since the backbone of transfer learning is a very large network, almost each type of label needs to use more than 20-100 images to complete the training of the later levels of the neural network (Pan S.J., 2010).

(3) Training Steps

Step 1: Make dataset

Using the labeling tool of the deep learning platform, 10 images of yellow feather broilers with large distribution differences were selected, followed by the labeling of the broilers and troughs in the images.

Step 2: Training

The dataset was trained by NAS and transfer learning. The initial training time was 670 s, and the average recognition accuracy for broilers and troughs were 75.17% and 100%, respectively. The results are shown in Figure 8.

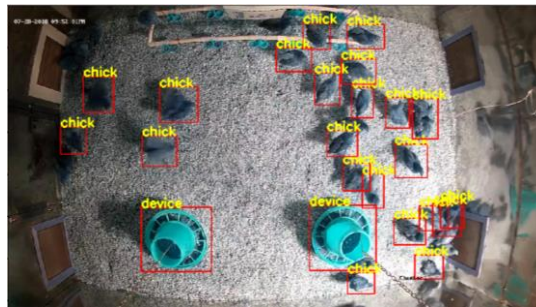

Fig. 8 - The recognition results of the detection model trained by NAS and transfer learning

Step 3: Extended dataset

Due to the use of transfer learning, the 10-image training model has met the requirement for further analysis. In order to further improve the accuracy of the model, the data set was expanded for retraining.

Table 1

The results of model training

Training set size (the number of pictures)	Average precision	
	Yellow feather broiler	Device
10	75%	100%
20	81%	100%
30	76%	100%
40	79%	100%
50	83%	100%
60	81%	100%

From the results in Table 1, it can be seen that the model trained with 50 images has the best effect, and the average recognition accuracy of broilers reaches 83%, which can meet the requirement for further analysis. Therefore, this paper selects this model as the final broiler detection model.

RESULTS

Analysis of Distribution Characteristics

In order to study the distribution of broilers under heat stress, the broiler chamber is divided into four areas, i.e. water trough, trough, vent and other areas. The specific division is shown in Figure 9.



Fig. 9 - The specific division of the areas in the chamber

When the cameras worked, the temperature gradually rose from 30°C to 34°C in the broiler chamber. The image was acquired every 30 s, and the distribution index of each area was calculated according to Equation (6) (Lao F., 2017).

$$d_i = \frac{n_i}{N} \times 100\% \quad (i=1,2,3,4) \tag{6}$$

where: d_i is the distribution index of broilers in sub-region i , n_i is the number of broilers captured in sub-region i (more than half of the framed area of extracted broilers is regarded as one broiler in this sub-region), and N is the total number of broilers captured in the current image.

There existed the phenomenon of missing detection in the broiler extraction process. To solve this problem, the images with serious missing detection were manually extracted and the distribution index obtained above was averaged every 10 groups as a new sample value according to Equation (7).

$$D_i = \frac{\sum_{j=1}^{10} d_{i,j}}{10} \quad (i=1,2,3,4) \tag{7}$$

where: D_i is the distribution index averaged for the i sub-region, $d_{i,j}$ is the distribution index in the j image of the i sub-region. The curves of distribution index over 3 days are shown in Figure 10.

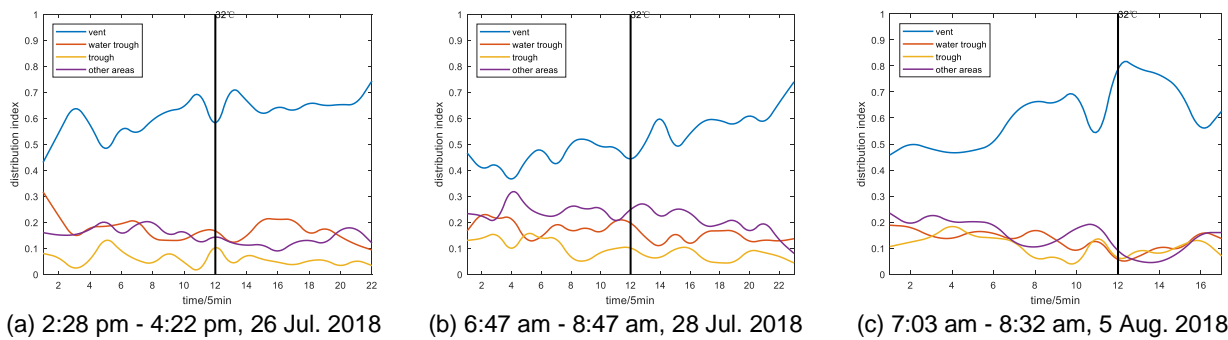

Fig. 10 - The curves of distribution index

Table 2

The change of distribution index of broilers with the temperature

Location	Date	30~32°C (%)	32~34 °C (%)	Rate of change
Vent	7.26	60	69	+0.15
	7.28	47	62	+0.32
	8.5	59	71	+0.20
Water trough	7.26	18	15	-0.17
	7.28	18	13	-0.28
	8.5	13	11	-0.15
Trough	7.26	6	4	-0.33
	7.28	11	6	-0.45
	8.5	11	9	-0.18
Other areas	7.26	16	12	-0.25
	7.28	24	19	-0.21
	8.5	17	9	-0.47

Figure 10 and Table 2 show that under the condition of heat stress, yellow feather broilers tend to be near the vent more and more with the increase of temperature, and it is especially obvious after the temperature in the chamber reaches 32 degrees. When the heat stress is more serious (above 32 degrees), about 68% of the broilers are distributed near the vent, 13% are distributed near the water troughs, 6% are distributed near the troughs, and 13% are distributed in other areas. Therefore, when heat stress occurs, yellow feather broilers tend to gather in cool places.

Activity Analysis

The activity of yellow feather broilers is calculated as follows. The activity index (AI) of yellow feather broilers at time t is defined as the area of the staggered part of the yellow feather broilers' coverage area at two times of $-\Delta t$ and $t+\Delta t$ (it is considered that the overlapped part of yellow feather broilers did not move within $2\Delta t$) (Aydin A., 2010). Equation (8) calculates the number of pixel points that are opened incorrectly, and Equation (9) obtains the area of the staggered area.

The larger the area, the greater the total activity of yellow feather broilers in $2\Delta t$, the greater the activity index of broilers at time t . The activity index is calculated by:

$$\Delta pixel = P_{t+\Delta t} \cap (1 - P_{t-\Delta t}) \tag{8}$$

$$\Delta S = \Delta pixel \times 1.044 \times 10^{-5} \tag{9}$$

$$AI_t = \Delta S / 2 \tag{10}$$

In the dataset, the relationship between image pixels and the actual area is expressed as:

$$1 pixel = 5.51 / 52780 m^2 \approx 1.044 \times 10^{-5} m^2 \tag{11}$$

As shown in Figure 11, Figure 11 (a) and 12 (b) represent the images at time $t-\Delta t$, $t+\Delta t$, respectively, and Figure 11(c) shows the staggered areas, where the sum of the areas of all white regions is ΔS .

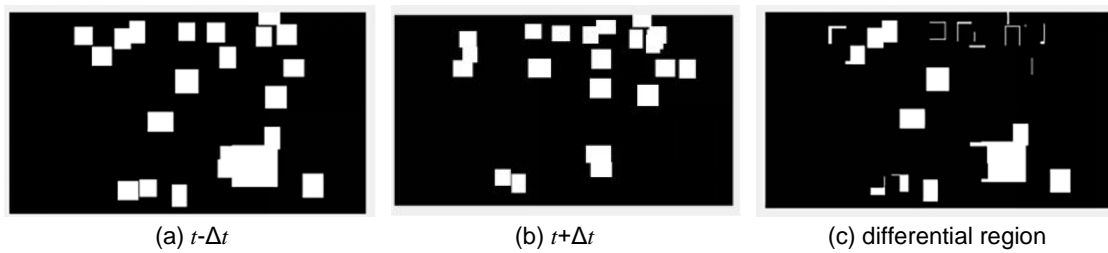

Fig. 11 - Schematic diagram of calculating the staggered areas

In this paper, the images with obvious high temperature in 7.26, 7.28 and 8.5 days were selected to calculate the activity index of broilers before and after the occurrence of $32^\circ C$. The results are shown in Figure 12(a), 12(b) and 12(c). Due to the uncertainty of the activity of a single broiler in the broiler flock, the activity of the broiler flock at a single moment cannot represent the activity of the broiler during the whole period. Therefore, the activity indexes over the period were summed. Figure 12(d) shows the activity indexes after the summing operation every 40 min. The specific results are shown in Table 3.

From Figure 12 and Table 3, it can be seen that within 3 h after the temperature rose to $30^\circ C$ in three days, the activity index of the broilers decreased from $13.39 m^2/40 min$ to $10.08 m^2/40 min$, a decrease of 22.54%. This indicates that the activity of the broilers decreased significantly after the heat stress occurred for a period of time.

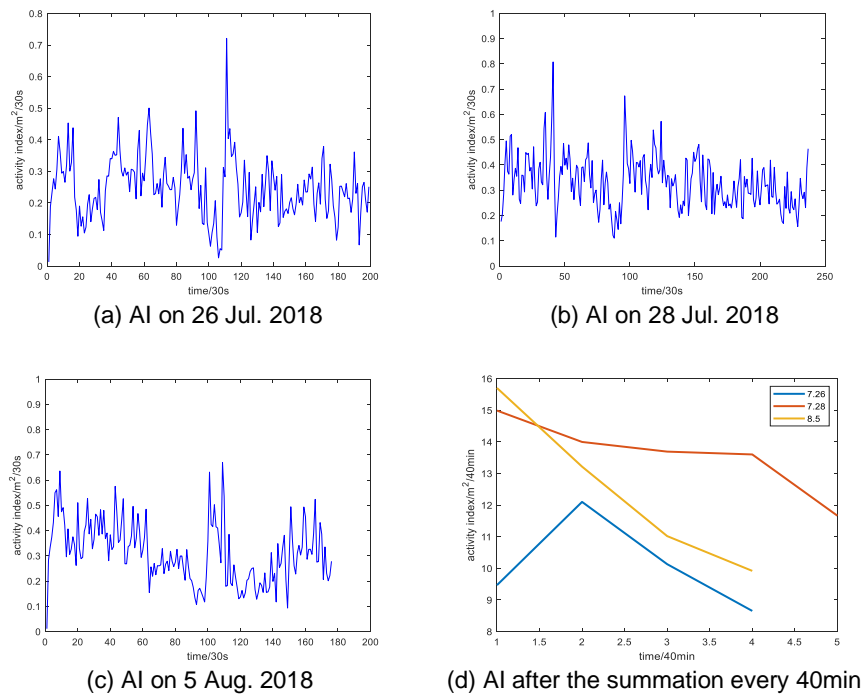

Fig. 12 - The results of AI

Table 3

Date	Activity Index (m ² /40min)			Decrease (%)
	T≤30 °C	T≥32 °C	Decrease of AI	
26.07.2018	9.47	8.65	0.82	8.61
28.07.2018	14.99	11.67	3.33	22.18
05.08.2018	15.71	9.92	5.79	36.84
average	13.39	10.08	3.31	22.54

CONCLUSIONS

The changes of biochemical properties of broilers under heat stress have been extensively investigated, but the group behaviour is rarely seen. In order to accurately locate yellow feather broilers, the algorithm of multi-target detection is discussed, and the detection model of broiler is determined by referring to PaddlePaddle and the algorithms of NAS and transfer learning. The average recognition accuracy reached 83%. Compared with the traditional background difference method, improved performance has been seen in the results by threshold segmentation method based on RGB space, colour clustering method based on YCbCr space and YOLOv3 method.

On the basis of the accurate extraction of broilers, we have investigated the changes of group behaviour indexes of broilers under heat stress. According to the distribution characteristics of broilers, the broiler chamber is divided into four areas, namely vent, water trough, trough and others. A large number of broiler images are processed by the detection model, and the traditional distribution index is also modified, so as to obtain more accurate results. The results show that when heat stress occurs, yellow feather broilers tend to gather at the vent. When the temperature continues to increase, the proportion of broilers at the vent increases from 53.3% to 67.3%.

According to the analysis of broiler's activity, the staggered area of broiler's area detected before and after the time is used as the activity index at the current time. The results show that the activity index is 13.39 m²/40 min when the temperature is less than 30°C, and it decreases to 10.08 m²/40 min, a decrease of 22.54%, within 3 h after the temperature rises to 30°C. The research results obtained by image processing technology and deep learning algorithm help farmers take effective measures to reduce the loss.

ACKNOWLEDGEMENT

This research was jointly supported by the Fundamental Research Funds for the Central Universities of China (KYTZ201661), China Postdoctoral Science Foundation (2015M571782), Jiangsu Agricultural Machinery Foundation (GXZ14002) and University Student Entrepreneurship Practice Program of Jiangsu Province (NO. 201810307010P).

REFERENCES

- [1] Aydin A., Cangar O., Ozcan S.E. et al., (2010), Application of a fully automatic analysis tool to assess the activity of broiler chickens with different gait scores, *Computers and Electronics in Agriculture*, Vol.73, Issue 2, pp.194-199, Wageningen/Netherlands;
- [2] Braham M. and Droogenbroeck M.V., (2016), Deep background subtraction with scene-specific convolutional neural networks, *International Conference on Systems, Signals and Image Processing*, Bratislava/Slovakia;
- [3] Das A. and Ghoshal D., (2016), Human skin region segmentation based on chrominance component using modified watershed algorithm, *Procedia Computer Science*, Vol.89, pp.856-863, Bangalore/ India;
- [4] Dawkins M.S., Cain R. and Roberts S.J., (2012), Optical flow, flock behaviour and chicken welfare, *Animal Behaviour*, Vol.84, Issue 1, pp.219-223, London/U.K;
- [5] Dong X., Wang K. and Jia G., (2009), Moving object and shadow detection based on RGB colour space and edge ratio, *2nd International Congress on Image and Signal Processing*, Tianjin/China;
- [6] Girshick R., Donahue J., Darrell T. et al., (2014), Rich feature hierarchies for accurate object detection and semantic segmentation, *CVPR*, pp.580-587, Columbus/Ohio;

- [7] Goo D., Kim J.H., Park G.H. et al., (2019), Effect of heat stress and stocking density on growth performance, breast meat quality, and intestinal barrier function in broiler chickens, *Animals*, Vol.9, Issue 3, 107, Basel/ Switzerland;
- [8] Habashy W.S., Milfort M.C., Adomako K. et al., (2017), Effect of heat stress on amino acid digestibility and transporters in meat-type chickens, *Poultry Science*, Vol. 96, Issue 7, pp. 2312-2319, Oxford/U.K.;
- [9] Huang S., Fu Y., Rehman M.U. et al., (2018), Effect of the acute heat stress on serum endotoxin concentration and the expression of TLR4 mRNA in liver of Arbor Acres broiler chickens, *Animal Production Science*, Vol.58, Issue 12, pp.2200-2206, Clayton South VIC /Australia;
- [10] Lao F., Du X. and Teng G., (2017), Automatic recognition method of laying hen behaviours based on depth image processing, *Transactions of the Chinese Society for Agricultural Machinery*, Vol. 48, Issue 1, pp. 155-162, Beijing/China;
- [11] Leroy T., Vranken E., Brecht A.V. et al., (2006), A computer vision method for on-line behavioural quantification of individually caged poultry, *Transactions of the ASABE*, Vol.49, Issue 3, pp.795-802, Michigan/USA;
- [12] Liu L., Shen M., Bo G. et al., (2014), Sows parturition detection method based on machine vision, *Transactions of the Chinese Society for Agricultural Machinery*, Vol.45, Issue 3, pp.237-242, Beijing / China;
- [13] Pan S.J. and Yang Q., (2010), A survey on transfer learning, *IEEE Transactions on Knowledge and Data Engineering*, Vol. 22, Issue 10, pp. 1345-1359, Los Angeles/USA;
- [14] Patvardhan C., Kumar P. and Vasantha Lakshmi C., (2017), Effective colour image watermarking scheme using YCbCr colour space and QR code, *Multimedia Tools and Applications*, Vol.77, Issue 10, pp. 12655-12677, Dordrecht/Netherlands;
- [15] Prasetyo E., Adityo R.D., Suciati N. et al., (2017), Mango leaf image segmentation on HSV and YCbCr colour spaces using Otsu thresholding, *3rd International Conference on Science and Technology - Computer*, Yogyakarta/Indonesia;
- [16] Redmon J. and Farhadi A., (2017), Yolo9000: Better, faster, stronger, *CVPR*, pp.6517-6525, Hawaii/USA;
- [17] Redmon J., Divvala S., Girshick R. et al., (2016), You only look once: Unified, real-time object detection, *CVPR*, pp.779-788, Las Vegas/USA;
- [18] Ren S., He K., Girshick R. et al., (2015), Faster R-CNN: Towards real-time object detection with region proposal networks, *IEEE Transactions on Pattern Analysis and Machine Intelligence*, Vol.39, pp.1137-1149, Los Angeles/USA;
- [19] Shaik K.B., Ganesan P., Kalist V. et al., (2015), Comparative study of skin colour detection and segmentation in HSV and YCbCr colour space, *Procedia Computer Science*, Vol.57, pp.41-48, Ghaziabad India;
- [20] Shakeri M., Cottrell J., Wilkinson S. et al., (2018), Betaine and antioxidants improve growth performance, breast muscle development and ameliorate thermoregulatory responses to cyclic heat exposure in broiler chickens, *Animals*, Vol. 8, Issue 10, 162, Basel/ Switzerland;
- [21] Wang D., He Y., Li D. et al., (2018), An improved infrared video image pedestrian detection algorithm, *Journal of Xi'an University of Posts and Telecommunications*, Vol.23, Issue 4, pp.48-52+67, Xi'an / China;
- [22] Yang J., Shi M. and Yi Q., (2012), A new method for motion target detection by background subtraction and update, *Physics Procedia*, Vol.33, pp.1768-1775, Amsterdam/Netherlands;
- [23] Yao H., Sun Q., Zou X. et al., (2018), Research of yellow-feather chicken breeding model based on small chicken chamber, *INMATEH - Agricultural Engineering*, Vol.56, Issue 42, pp.91-100, Bucharest/Romania;
- [24] Zhang H., Du Y., Ning S. et al., (2019), Pedestrian detection method based on faster R-CNN, *Transducer and Microsystem Technologies*, Vol. 38, Issue 2, pp. 147-153, Beijing/China;
- [25] Zhang S., Ding A., Zou X. et al., (2019), Simulation analysis of a ventilation system in a smart broiler chamber based on computational fluid dynamics, *Atmosphere*, Vol.10, Issue 6, 315, Basel/ Switzerland;
- [26] Zhao K. and He D., (2015), Target detection method for moving cows based on background subtraction, *Int J Agric & Biol Eng*, Vol. 8, Issue 1, pp. 42-49, Faisalabad/Pakistan;
- [27] Zoph B. and Le Q.V., (2017), Neural architecture search with reinforcement learning, *ICLR*, pp.1-16, Toulon/France.