



Design of Automotive Engine Hoisting Device for Mechanical Applications

Owunna Ikechukwu and Ikpe Aniekan E

Department of Mechanical Engineering, Coventry University, UK
ikpeaniekan@gmail.com

ABSTRACT

Heavy duty tasks such as engine replacement and dropping, involves engine rebuilds or upgrades, repairs, engine bay rehabs, and other complex operations that involves the movement of heavy engine parts in the workshop from one place to another. The entire process usually takes time depending on the hoisting device employed. For example, chain hoist requires more time with human efforts for support and can only carry limited engine weight capacity, whereas, hydraulic hoist can carry heavier engine than chain hoist and electrical hoist. However, Electrical hoist can handle engine weight of about 200Kg (approximately 2KN) but with greater speed than chain hoist and hydraulic hoist. In this paper, three design concepts were considered for hoisting Robin Hood engine and gear box which is about 193Kg and the second concept which operates electrically was selected in terms of performance, cost, interaction, safety and ergonomics. The design efficiency obtained was 66.7% and the final engine hoisting design concept selected met all the requirements including tilting capacity of up to 30 degrees.

Keywords: Design, Hoist, Automotive engine, Load capacity, Safety, Ergonomics

INTRODUCTION

An engine hoist also known as an engine crane, cherry picker, or an engine lift is a device that is applicable in the lifting or lowering process of load by means of a drum or lift-wheel by wrapping rope or chain (which is an integral part of the hoisting device) around the object to be lifted [1-2]. An engine hoist consists of a strong support structure that is most often made out of welded steel or aluminum. It incorporates a cantilever beam that extends from the frame that has chain attachments designed to connect the tool to the anchored point of the engine. Its operation may be achieved manually, electrically or pneumatically and may use chain, fiber or wire rope while lifting a given load from one point to another [4]. The load is anchored to the hoisting device by means of a hook. Some hoist enables the operator to lift engines out of their compartments and maneuvers them into work areas. The three basic types of hoisting devices commonly used for load lifting applications include hydraulic, electric and chain hoists [3]. Each type of hoisting device has their advantages and disadvantages, but they all can be used to achieve a common goal in terms of taking out the car engine for repairs and vice versa. Engine hoist is important in the sense that the average engine weighs about 400-600lb (182-272Kg), and may be highly cumbersome to achieve if human effort is employed in the removal process [2]. Also, the least safe act in an engine removal process is when it is being lifted outwards from the engine seat having loosed the bolts and nuts, and the engine suddenly experience free fall from a certain height [9]. Studies have shown that manual handling of heavy loads such as the automotive engine or its parts can result in severe health problems such as Musculoskeletal disorders, tremors of the hand, misalignment of slip disc in pelvic region, Lumbar scoliosis etc [15-16]. However, time and safety is of great essence to engineering practices and this has necessitated this research paper to save the time required for engine swaps as well as the energy and danger that auto mechanics are exposed to when dealing with complex tasks involving heavy duty engines and their accessories.

METHODOLOGY

A number of typical failure mechanisms in hoisting devices are caused by material defect, poor design, overloading, negligence of safety standards etc. To ascertain the integrity of this design, centre of gravity of the engine and gear-box which the hoisting device is designed for will be analysed, Design concepts will be considered and the most

suitable - design will be selected based on key requirements and constrains. CES Edupack Software will be adopted for the selection of appropriate material that will suite customer’s satisfaction. To meet the possible design requirements, a Quality Function Deployment (QFD) analysis of the hoisting device will be analysed in terms of functional and customer requirements. Each of the parts constituting the device will be designed using CATIA software 2015 version and the final automotive hoisting assembly design will be carried out.

ANALYSES FOR THE CENTRE OF GRAVITY OF ENGINE AND GEARBOX

Centre of gravity is where any load's entire weight is concentrated, and Loads oftentimes tend to have their centre of gravity below the point of support. The higher the centre of gravity is located in the load, the wider and more stable - the base of support needed to maintain the static equilibrium [7-8]. In this case, a system needs to be defined which is able to lift the engine and gearbox of the Robin Hood car. The main task is to first lift the engine and gearbox up to a nominal height and then tilt it at an angle of 30 degrees and then take the whole structure out of the car. Considerations for Centre of gravity of the engine and gearbox are as follows:

Height of engine on paper = 89mm, Measured height of engine = 665mm, Measured width of engine = 190mm
 Scale = 89mm: 665mm,
 Hence, 1mm: 7.47mm
 Width of gearbox on paper = 120mm
 Therefore, width of gearbox = 120×7.47 = 896.63mm
 Height of gearbox on paper = 34mm
 Therefore, height of gearbox = 34×7.47= 253.98mm
 The total mass for Robin Hood Car engine and gearbox is presented in Table -1.

Table - 1 Total Mass for Robin Hood Car Engine and Gearbox

Parts	Mass M (Kg)	X(mm)	Y (mm)	M.X (kg.mm)	M.Y (kg.mm)
Engine	160	95	332.5	15200	53200
Gearbox	33	448.3	127	14798.9	4191
	$\Sigma M = 193$			$\Sigma M.X = 29998.9$	$\Sigma M.Y = 57391$

Centre of gravity $X = \frac{\Sigma M.X}{\Sigma M} = \frac{29998.9}{193} = 155.4\text{mm}$ (1)

Centre of gravity $Y = \frac{\Sigma M.Y}{\Sigma M} = \frac{57391}{193} = 297.4\text{mm}$ (2)

The load weight for either the engine or the gearbox can be determined using the size formula for solid objects [10] as shown in equation 3, and this incorporates the length, width and height of a given body.

Size formula for solid objects = $L*W*H$ (3)

Figure 1 represents the various design concepts considered in this study, as shown in Fig 1, design concept 1 is made up of 2 balance bar, internal Gear system with a total of 8 gears, 4 rollers, 2 standing bar, 1 top horizontal bar. It has a system of gears which results in vertical motion of the system. The system has a combination of gears at the mid-section of the vertical shaft. The gear member moves vertically upwards, translating the vertically upward movement into the lifting operation of the jack. Medium carbon steel was considered because it is suitable - for moderately stressed applications. Design concept 1 is rated based on its mobility and ability to carry heavy loads, while at the other hands, it is very expensive, difficult to produce, requires a lot of energy to operate as well as high maintenance requirements.

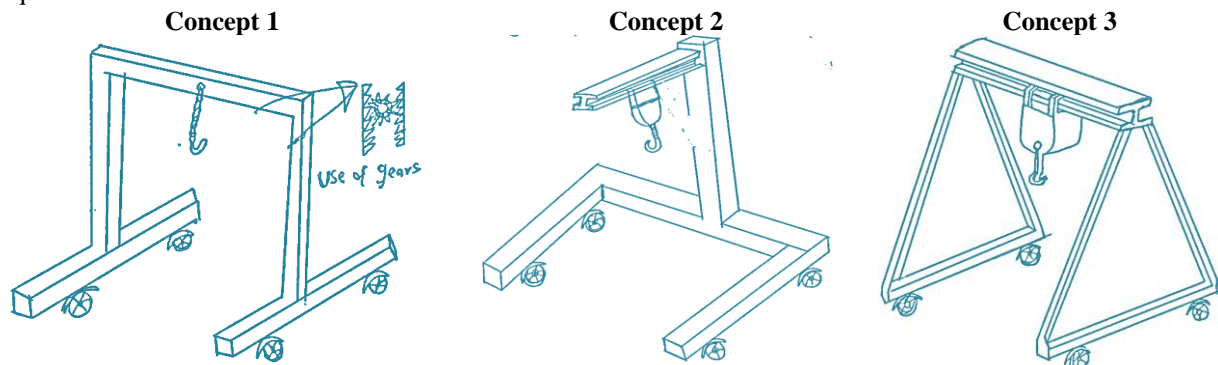

Fig. 1 Design Considerations for Automotive Engine Hoisting

As presented in Fig 1, Concept 2 is composed of 2 balance bar, 4 rollers, 1 standing bar, 1 top horizontal bar, 1 electrical hoist. The system incorporates electrical hoist which is used in manoeuvring the lifting of the engine from the car and back to the car. The I-beam provides the strength and rigidity needed to support the system and it is foldable at any given time when not in use. Mild steel was considered for the design because it is typically ductile, machinable, weldable and less expensive which makes it suitable - for structural members [13]. Design concept 2 was rated based on its mobility and ability to carry heavy loads, occupies less space, energy requirement is moderate, while at the other hands, it may not carry too heavy load due to the simplicity of the design.

Similarly, concept 3 involves the use of electrical hoist which makes it possible to lift the engine from the engine seat, with the ability to tilt, manoeuvre and control it to ground level. The system has many attachments that allows decoupling, but however has a space problem such that, if the vehicle is bigger than the space within the frame, this concept cannot be used.

Design Requirement

- The selected design must be capable of safely lifting the overall load of 193 kg of which engine weights 160 kg and the gearbox weights 33 kg.
- It must be able to produce a lifting force of 2000 N.
- It must be able to lift the weight from a minimum height of 100 mm.
- The design should be able to lift and lower the structure at a controlled pace to minimize waiving of the structure.
- Need to design the system to lift the engine out of the vehicle and able to tilt 30 degrees since the engine is attached with the gearbox.
- The design should be compact and efficient.
- The design should be easy to use, 'fold-away' or dismantle for storage.
- The system will be operated by one operator.

Design Constraints

- Need to design the system to lift the engine out of the vehicle and able to tilt 30 degrees since the engine is attached with the gearbox.
- The design should be compact and efficient.
- The design should be easy to use, 'fold-away' or dismantle for storage.
- Mass of the engine is 160kg and that of the gearbox is 33kg.
- The total mass is 193kg and weight is (mass x acceleration due to gravity) 1.93kN.
- The design need to be innovative.
- The system will be operated by one operator.
- The client requires 500 units to be manufactured.

Table - 2 Constraints Filter

Constraints→	1	2	3	4	5	6	7	8
Concept 1	o	x	o	x	x	x	x	x
Concept 2	x	x	x	x	x	x	x	x
Concept 3	x	x	x	o	x	x	x	x

Table - 3 Design Concept Selection Chart

Functional Requirement	Concept 1			Concept 2		Concept 3	
	Wt.	Rate	Weighted	Rate	Weighted	Rate	Weighted
Safety	5	7	35	8	40	8	40
Performance (speed)	5	8	40	10	50	7	35
Interaction	4	8	32	8	32	4	16
Cost	2	8	16	3	6	3	6
Ergonomics	3	5	15	8	24	5	15
Total			138		152		112

From the above design requirements and constraints considered in this study, the constraints filler used in selecting the desired design concept is as shown in Table - 2, whereas, Table - 3 represents the design concept selection chart.

Comparably, concept 2 has been proven to be the selected concept since it met the entire requirement, with the highest point in the design matrices shown in Table - 2 and 3 respectively. The selected concept has a vertical bar like the I beam which the bending effect can be determined using the generic beam bending equation as expressed in equation 4. In this case, the bending effect depends majorly on the load acting on the beam and the material used [6].

$$\frac{M}{I} = \frac{\sigma}{y} \quad (4)$$

Where: σ is the stress at distance y from neutral axis of beam, M is the bending moment of the beam, y is the distance from the neutral axis and I is the second moment of area.

From equation 4, stress at distance y from neutral axis of beam can be express as shown in equation 5

$$\sigma = \frac{M}{I} \times y \quad (5)$$

To determine the buckling load acting on the beam, the second moment of area is given as shown in equation 6,

$$I = \frac{1}{12} \times b \times h^3 \quad (6)$$

Where h = the height of the I beams and b = the width of the I beam

Considering the load bearing capacity of the hoisting device, the formula for critical load P_{cr} (also known as the Euler buckling load) that will result in buckling [12] is given in equation 7,

$$P_{cr} = \frac{\pi^2 \times E \times I}{l^2} \quad (7)$$

Where E = Young's Modulus of elasticity and l = length of the I beam

The stiffness of a beam is related to its material and geometry, and this is given in equation 8,

$$k = \frac{F}{\delta} = \frac{3EI}{l^3} \quad (8)$$

The mass of the I beam is given in equation 9,

$$Al\rho \quad (9)$$

Where A = the cross-sectional area of the beam, ρ = is the material density, F = end load and δ = deflection

Considering the above theories, governing equations for normal bending stresses in I beams are based on the following assumptions,

- The beam is subjected to pure bending effect. This implies that the shear force is zero, and that torsion or axial loads are not present. The material is isotropic or homogeneous.
- The material obeys hooks law.
- The beam is initially straight with a cross section that is constant throughout the length of the beam.
- The beam has an axis of symmetry in the plane of bending.
- The portions of the beam are such that it would fail by bending rather than by crushing, wrinkling or sidewise buckling.
- Plane cross section of the beam remain plane during bending.

However, if the stress is uniformly distributed across the beam, it can be calculated as shown in equation 10, and the maximum design load should not exceed the allowable stress [11] of the of the hoisting device

$$\sigma = \frac{F}{A} \quad (10)$$

When the hosting device is used in carrying automotive engines of a given weight, there are resultant forces acting on the structural joints, with a net force and moment equal and opposite to the reaction loads V_1 and M_1 acting on the mechanical bolts at the joints. In such cases, the load is distributed evenly across the total number of bolts in the device, and the total load supported by each bolt can be determined in the following steps,

- The shear force V_1 is divided equally among the number of bolts involved, such that each bolts takes,

$$F' = \frac{V_1}{n} \quad (11)$$

Where, n is the number of bolts involved, and the force F' is the direct load or primary shear.

- The moment load or secondary shear is the additional load supported by each bolt as a result of the moment M_1 . Considering the radial distances from the centroid to the mid-section of each bolt, the moment and moment loads can be represented as shown in equation 12,

$$M_1 = F_A''r_A + F_B''r_B + F_C''r_C + \dots \quad (12)$$

Where, r_A , r_B , r_C are the radial distances and F'' are the moment loads. During operation of the hoisting device, the force supported by each bolt is dependent on its radial distance from the centroid, which therefore implies that the bolt farthest from the centroid absorbs the highest load, whereas, the nearest bolt to the centroid absorbs the smallest load. This can be expressed as shown in equation 13,

$$\frac{F_A''}{r_A} = \frac{F_B''}{r_B} = \frac{F_C''}{r_C} \quad (13)$$

Solving equation 12 and 13 simultaneously, equation 14 is obtained.

$$F_n'' = \frac{M_1 r_n}{r_A^2 + r_B^2 + r_C^2 \dots} \quad (14)$$

Where, the subscript n is particular bolt whose load is to be determined.

- In this step, both the direct loads and moment loads are added together vectorially to arrive at the resultant load on each bolt. In cases were the bolt sizes are the same, only the bolts subjected to maximum loading conditions may be considered.

Quality Function Deployment

Quality Function Deployment (QFD) is an approach developed in early 1966 in Japan to help transform the voice of the customer (VOC) into engineering attributes for a given product. As shown in Fig 2, QFD is created to enable a better understanding of the basic design requirements from the customer's perspective [5].

Table -5 Chemical Composition of a Typical Mild Steel [14]

Elements	Fe	C	Si	Mn	P	S	Cr	Al	Cu
Compositions (%)	99.2	0.134	0.074	0.404	0.056	0.022	0.16	0.002	0.009

Table -6 List of Design parts for the Final Design

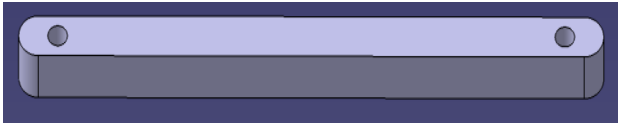
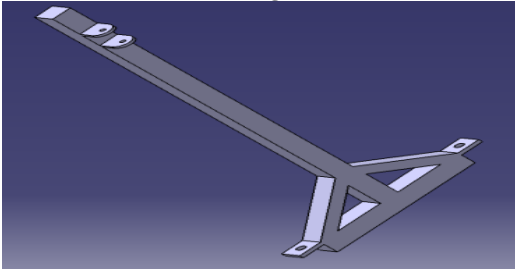
Design parts	Material	Function
<p>Top Horizontal Bar</p> 	Mild Steel	The horizontal bar connects the standing bar and the electric hoist. It produces some of the forces for lifting the engine.
<p>Ground Balance Bar</p> 	Mild Steel	The ground balance bar is fixed on the ground roller. It is used for stability and balance if the system. Forces are distributed on the ground balance bar.
<p>Standing Bar</p> 	Mild Steel	The standing bar is the pillar of the system. It holds the horizontal bar horizontally for lifting of the engine.

Electric Hoist

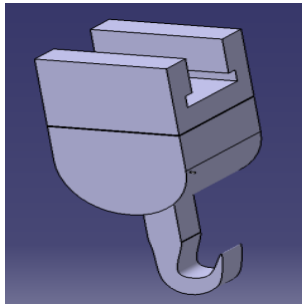

Mild Steel /Electrical Components

The electric hoist is used to lift the engine from the car. It is operated with electrical energy. The electric hoist converts electrical energy into kinetic energy.

Mechanical Nut 30

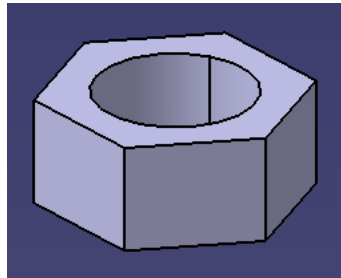

Mild Steel

The mechanical nut is used to fasten the horizontal bar and the standing bar together.

Ground Roller

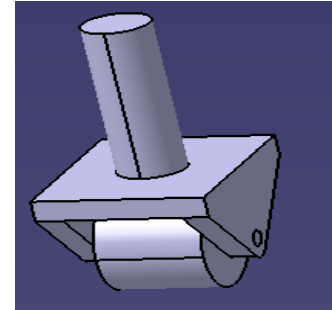

Plastic/ Mild steel

The ground roller used for easy movement of the system, especially when it is carrying loads.

Mechanical Bolt 30

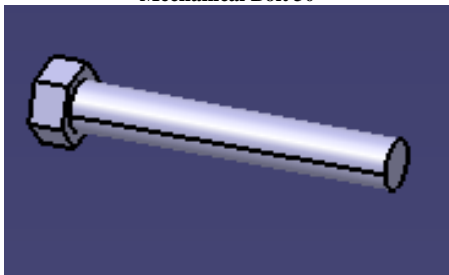

Mild Steel

The mechanical bolt is used also to fasten the horizontal bar and the standing bar together. It transfers the forces from the horizontal bar to the standing bar.

Engine Hanger



Mild Steel / Rubber

The engine hanger is used as a hook to the engine. It is also used to tilt the engine at an angle of 30 degrees.

Mechanical Nut 50

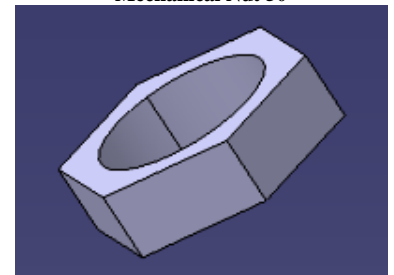

Mild Steel

The mechanical bolt 50 is used to fasten the ground roller and the ground balance bar together.

Final Design and Parts Using CATIA 2015 Version

The final designed Parts for the hosting device are presented in Fig 3-8,

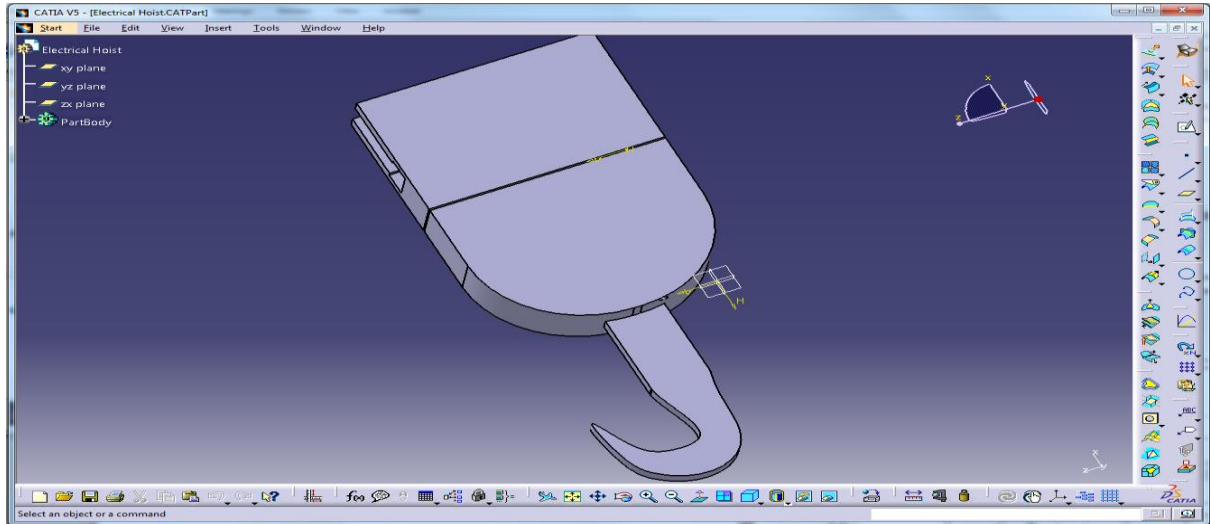

Fig. 3 Electrical hoist

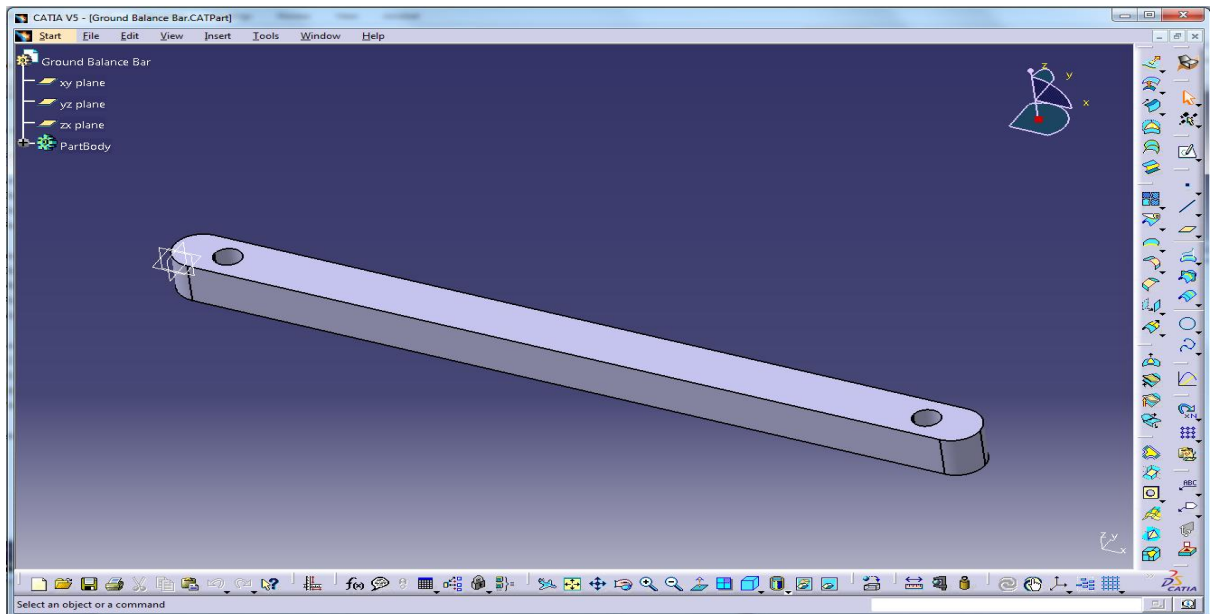

Fig. 4 Ground Balance Bar

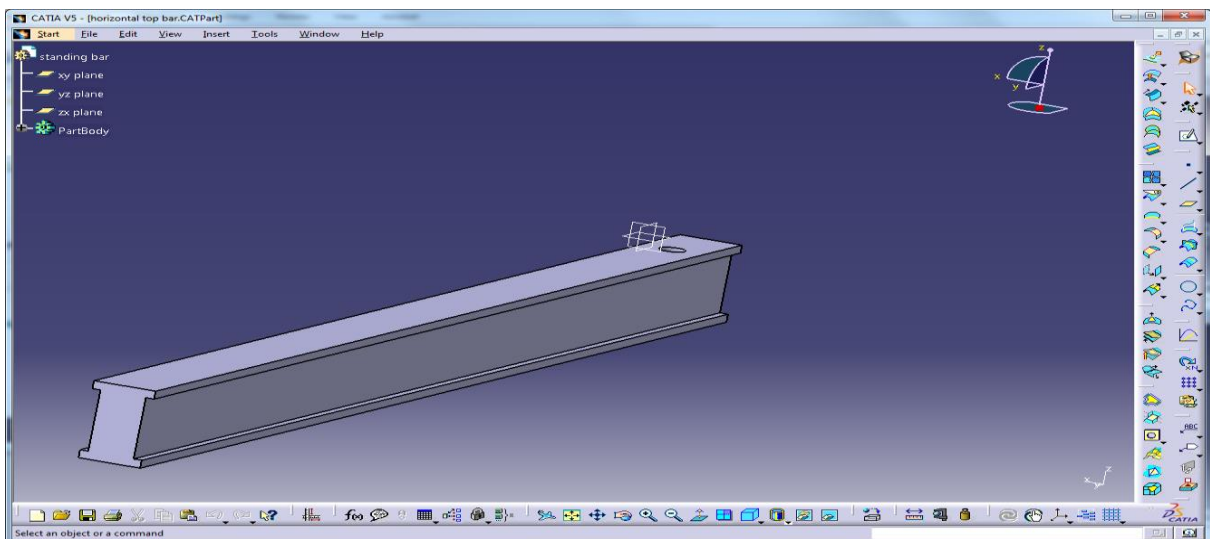

Fig. 5 Horizontal Top Bar

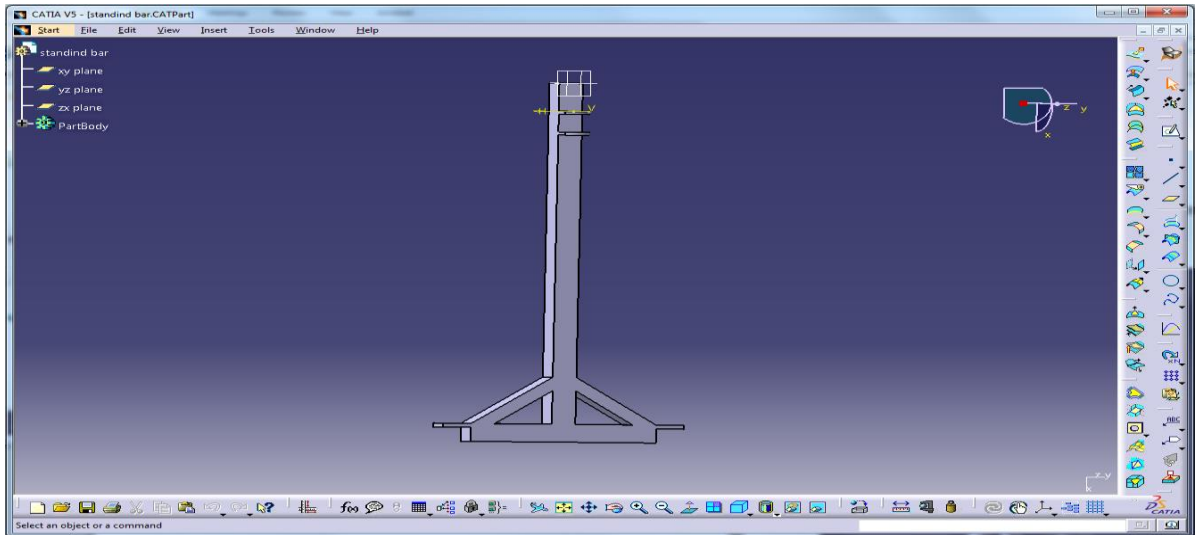

Fig. 6 Standing Bar

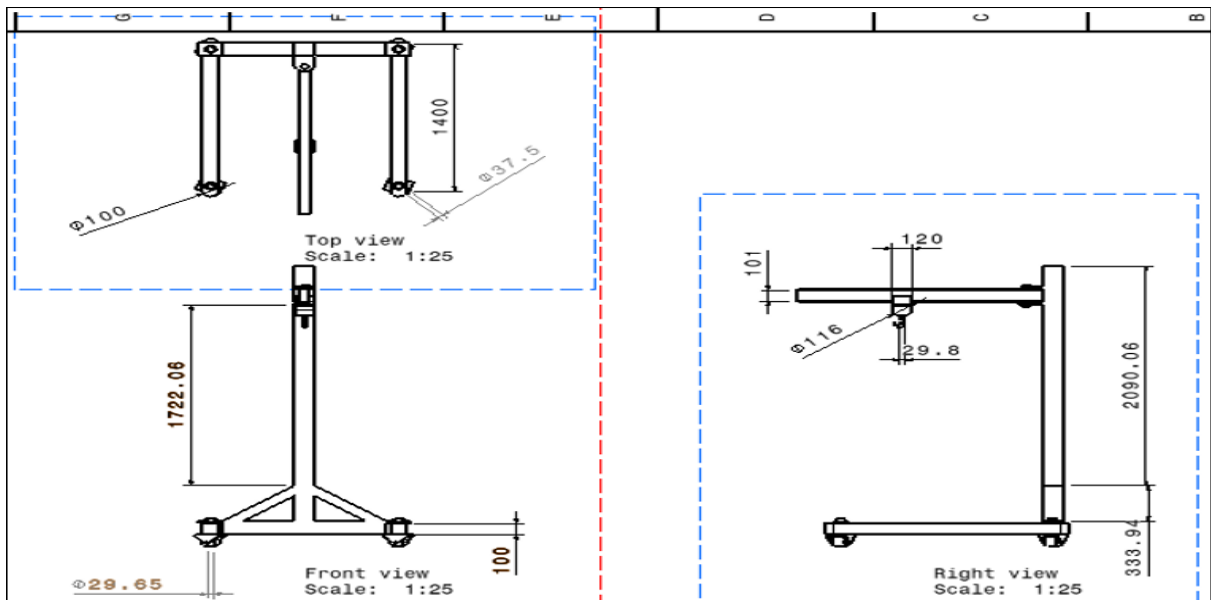

Fig. 7 Design Assembly

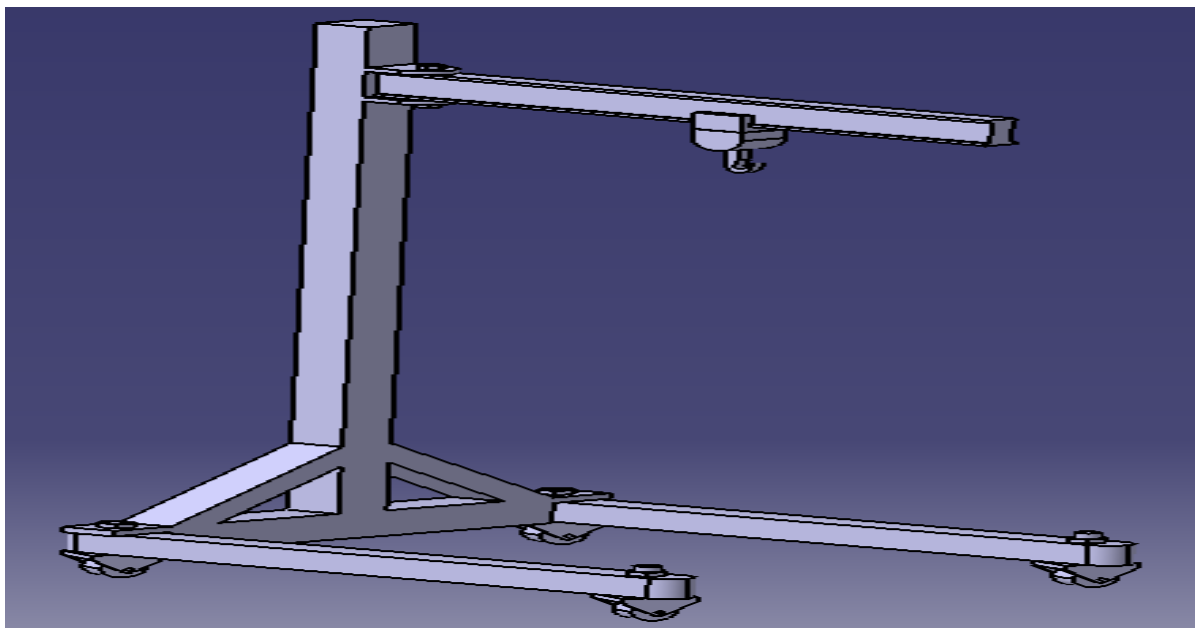

Fig. 8 Final Hoisting design



DISCUSSION

Ergonomics is related to motion study and human comfort. Ergonomics is the science of designing job, equipment, workplace to fit the people and their work. It is the scientific relation between man, machine and work environment. Ergonomic improvements involve prevention of occupational health and safety risks, improvement of work environment factors to enhance human well-being, productivity and quality through reduction of human error and discomfort. It has a quite a few aspects to concentrate on in order to make it appreciated by customer. It is a simple machine using basic ideas and principle of mechanics and so it has no fatigue because of its design in any part. It is easy to understand and simple to operate and that is one of the reasons why it is really easy for anyone to operate this mechanism. Control Element (Speed, accuracy, load). The controls of this design are capable of pulling required load and can yet be manipulated for human comfort. Movement are incompatible as they change the action if the direction of movement is changed. The energy demand for operating this machinery can be graded as moderate bodily work. Aesthetically the design has perfect symmetry and balance, Continuity of design can be described as good, it has got variety to suit its purpose and its proportion is just adequate for the task. It has a fast and strong impression of purpose. The selected concept is the combined system of the I-beam and electrical hoist. The electrical hoist was chosen as the lifting mechanism as it has the ability to lift the engine and gearbox system with the use of its control switches. Electrical hoist has an internal motor, which is operated using a remote control and provides the lifting power. That makes the electric hoist a fast device for lifting heavy loads like automotive engine. The process initially starts with attaching the hooks with the attachments of the engine. The engine and the gearbox system is then lifted using the electrical control switches and then lifted and tilted using the attachment system. The lever is rotated for 5 revolutions leading to the tilting of the system and performing the required task. Then the system is carefully lifted using the electrical switches at controlled pace. The electrical hoist is very useful in terms of making the system versatile and multi-purpose. It is able to lift the weights of up to 200Kg and suits as the best option of an electrical hoist to be used in the design. For safety reasons, Table - 7 summarises the issues, risks and control measures associated with the operation of the selected design concept. To determine the design efficiency, Design for Assembly (DFA) was drawn out for the number of parts that constitutes the entire design as shown in Table - 8.

Table -7 Safety, Risk and Control Measures for Operation of the Hoisting Device

Issue	Risk	Control Measures
Working Site	Injury to the operator.	The frame needs to be used on balance surface and clear space.
Lifting engine	Injury to the operator, damage to the vehicle.	Lifting load should not exceed the allowable load mentioned in the design.
Engine or the load attachment	Injury to the operator and damage to the vehicle or building.	The attachment to the engine must be double checked and the recommended attachments should be used [9].
Falling components	Injury to the operator and damage to the vehicle or building.	Lifting load must be anchored properly to the hoisting hook.
Heavy weather	Injury to the operator and the lifting object.	Weather or working atmosphere has to be observed before operation.
Non operation period	Damage to the building or vehicle.	Any load attached to the frame has to be unloaded before working hour is over.
Assemble the system	Failure in operation.	Assemble the frame according to user manual to avoid failure during operation.
Personal Protective equipment (PPE)	Injury to the operator.	Protective equipment should be used during operating, e.g. safety boots, hand gloves act.
Maintenance	Damage to the building and vehicle or the operator.	Routine checks and maintenance should be carried out on the system.

Table -8 Design for Assembly

Component	Handling 					Fitting 							Total	
	Size and weight (A)	Handling Difficulties (B)	End to End orientation (C)	Rotational orientation (D)	A+B+C+D	A	B	C	D	E	F	A+B+C+D+E+F		Non Assembly Process
Arm (A)	1.5	0	0.1	0	1.6	0	0	0	0	0	0	0	4	4
Legs (A)	1	0	0.1	0	1.1	0	0	0	0	0	0	0	4	4
Stand (A)	1.5	0	0.1	0	1.6	0	1.2	0	1.5	0	0	2.7	4	6.7
Hoist (B)	1	0	0.1	0	1.1	0	0	0	0	0	0	0	0	0
Bolts (A)	1	0	0.1	0	1.1	0	0	0	0	0	0	0	4	4
Wheel (B)	1	0	0.1	0	1.1	0	0	0	0	0	0	0	4	4
					7.6									22.7

$$\text{Design Efficiency} = \frac{\Sigma A \text{ parts}}{\Sigma \text{Total parts}} = \frac{4}{6} \times 100\% = 66.7\% \quad (15)$$

$$\text{Hanling Index} = \frac{\text{Handling}}{\text{Total number of A parts}} = \frac{7.6}{4} = 1.9 \quad (16)$$

$$\text{Fitting Index} = \frac{\text{Fitting}}{\text{Total number of A parts}} = \frac{22.7}{4} = 5.67 \quad (17)$$

CONCLUSION

Considering the design criteria and constraints for the design of an engine hoisting device, the requirements were met from the preliminary stage and planning through the embodiment design and then the concept design. Proper assessment of the final design of the system was carried out and a good design efficiency was obtained. However, to swap engines heavier than 2KN, operators will require standby electric source and electric motor of higher capacity which is more expensive but faster than hydraulic and chain hoist.

REFERENCES

- [1] SK Adzimah, AS Akinwonmi and B Bentum-Mensah, Improvement in the Design of Engine Crane for Modern Industries, *Research Inventory: International Journal of Engineering and Science*, **2013**, 2 (9), 1-9.
- [2] Floorjacked, Buyer's Guide: Choosing the Best Engine Hoist, [online] available at <http://floorjacked.com/buyers-guide-choosing-the-best-engine-hoist/>, **2017**.
- [3] B Miller, Different Engine Hoist Types and What They Are Used for Knock Out Engine, [online] available at <http://www.knockoutengine.com/different-engine-hoist-types-and-what-they-are-used-for/>, **2014**.
- [4] L Cveticanin, Dynamic Behaviour of the Lifting Crane Mechanism, *Mechanism and Machine Theory*, **1995**, 30 (1), 141-151.
- [5] AE Ikpe, I Owunna and P Satope, Design of a PorTable - Carrier System for Transporting Basic House-hold Utilities in Hatchback Family Cars, *European Journal of Advances in Engineering and Technology*, **2017**, 4 (2), 90-97.
- [6] RG Budynas and JK Nisbett Shigleys, *Mechanical Engineering Design*, Eighth Edition, McGraw-Hill, **2008**.
- [7] JM Hu, WH Ding and H Deng, Dynamic Modelling and Analysis of Lifting Mechanism for Forging Manipulator, *Applied Mechanics and Materials*, **2013**, 278-280, 633-640.
- [8] S Hutcheson, *Design and Construction of a Portable - Gantry Hoist*, California Polytechnic State University, San Luis Obispo, USA, **2013**.
- [9] National Aeronautics and Space Administration, *Safety Standard for Lifting Devices and Equipment*, Office of Safety and Mission Quality Washington, D.C. 20546, NASA-STD-8719.9, NSS/GO-1740.9B, **1991**.
- [10] V Suresh, and KJ Vijay, *Analysis and Design of Machine Elements*, IK International Publishing House Pvt Ltd, India, **2010**.
- [11] BJ Hamrock, SR Schmid and BO Jacobson, *Fundamentals of Machine Element*, 3rd Edition, CRC Press, **2013**.
- [12] RS Khurmi, *A Textbook on Engineering Mechanics*, 20th Revised Edition, S Chand and Company Ltd, New Delhi, India, **2009**, 171.
- [13] GF Limbrunner, C D'Allaird and L Spiegel, *Applied Statics and Strength of Materials*, 6th Edition, Pearson, **2015**.
- [14] PK Yadav, MD Abbas and S Patel, Analysis of Heat Affected Zone of Mild Steel Specimen Developed Due to MIG Welding, *International Journal of Mechanical Engineering and Robotic Research*, **2014**, 3 (3), 399-404.
- [15] US Department of Labour Occupational Safety and Health Administration, *Ergonomics: The Study of Work*, OSHA 3125, [online] available at <https://www.osha.gov/Publications/osha3125.pdf>, **2000**.
- [16] R Avantika and A Shalini, Back Problems Due to Heavy Backpacks in School Children, *IOSR Journal of Humanities and Social Science*, **2013**, 10 (6), 22-26.