



Fault Diagnosis in Cantilever Beam Using Fuzzy Logic

JR Chaudhari and CR Patil

¹Department of Mechanical Engineering, SSGB COE&T, Bhusawal, India

²Department of Mechanical Engineering, PRMIT&R, Badnera, India
jitendra_rc@rediffmail.com

ABSTRACT

Fault diagnosis is one of the major issues in every field of engineering, which may cause failure of the entire system. Fault diagnosis detection methods have been considerably increased over the past few decades. A presence of fault in structural member introduces local flexibility which affects the vibration response of the structure. The response of the system depends upon the type of fault occurs with its location. The damage in the structure leads to changes in natural frequencies and mode shapes. Early detection of presence of damage can prevent the catastrophic failure of the structures by appropriately monitoring the response to the system. In the present investigation fuzzy logic technique has been used to determine the fault in terms of crack. Here the transverse surface of the crack is considered and analyzed using FEA and fuzzy logic system. Analytical study has been performed on the cantilever beam with single crack to obtain the vibration characteristics of the beam. Here author intend to introduce fuzzy logic technique for fault diagnosis using several fuzzy rules. Here the first three natural frequencies are obtained and that are considered as input to fuzzy system. It is observed that the fuzzy controller can predict the depths and locations accurately close to the finite element analysis.

Key words: Vibration, Fault, Natural Frequency, Fuzzy Logic Techniques

INTRODUCTION

Crack is the potential source of failure in the field of engineering. Crack diagnosis in vibrating structure has drawn a lot of attention in mechanical machines and in civil structures and aerospace engineering. In the recent years the era of researchers has motivated towards development of intelligent techniques for crack detection. Many techniques have been employed in the past for damage identification. Some of these are visual (e.g. Dye Penetrant Method) and other NDT uses sensors to detect local faults (e.g. eddy current, magnetic field, radiographs, acoustics and thermal fields). In this chapter fuzzy logic technique has been projected for localization and identification of crack.

Fuzzy logic (FL) is a multi-valued logic, which allows interim values to be defined between linguistic expressions like yes/no, high/low, true/false. A form of knowledge representation suitable for notions that cannot be defined precisely, but which depend upon their contexts. Superset of conventional (Boolean) logic that has been extended to handle the concept of partial truth - the truth values between "completely true & completely false". Fuzzy logic has two different meanings as, in narrow sense: Fuzzy logic is a logical system, which is an extension of multi-valued logic. In a wider sense: Fuzzy logic (FL) is almost synonymous with the theory of fuzzy sets, a theory which relates to classes of objects with unsharp boundaries in which membership is a matter of degree.

A K Das *et al* [1] have discussed the influence of cracks to the dynamic behaviour of a cracked cantilever beam with rectangular cross section. Finite element analysis is being performed on the cracked structure to measure the vibration signature, which is subsequently used in the design of smart system based fuzzy logic in prediction of crack depths and locations following inverse problem approach. Huh *et al* [2] has proposed a new local damage detection method of damaged structures using the vibratory power estimated from accelerations measured on the beam structure. A damage index is newly defined by them based on the proposed local damage detection method and is applied to the identification of structural damage. Numerical simulation and experiment are conducted for a uniform beam to confirm the validity of the proposed method. In the experiments, they have considered the damage as an open crack such as a

slit inflicted on the top surface of the beam. Parhi and Choudhary [3] presented non-destructive method for the detection of crack in terms of crack depth and crack location with the consideration of natural frequency. The crack is analyzed using Fuzzy Logic System and Finite Element Analysis. Zadeh [4] introduced and briefly analysed the relevant properties of fuzzy sets, the notions of a fuzzy system and a fuzzy class of systems. The work constitutes a very preliminary attempt on introducing into system theory several concepts which provide a way of treating fuzziness in a quantitative manner. The paper closes with a section dealing with optimization under fuzzy constraints in which an approach to problems of this type is briefly sketched. Salam *et al* [5] has proposed a simplified formula for the stress correction factor in terms of the crack depth to the beam height ratio. They have used the proposed formula to examine the lateral vibration of a Euler-Bernoulli beam with a single edge open crack and compared the mode shapes for the cracked and undamaged beam to identify the crack parameters.

Agarwalla *et al* [6] uses the GA –Fuzzy controller for the identification of damage in steel cantilever beam in transverse direction subjected to natural vibration. Parhi and Choudhary [7] have analyzed the transverse surface crack using fuzzy logic system and finite element analysis. The fuzzy controller uses the hybrid membership functions (combination of triangular, trapezoidal and Gaussian) as input and trapezoidal membership functions as output. By using several fuzzy rules, the results obtained for crack depth and crack location in the Matlab Simulink environment and have been compared with the results obtained from finite element analysis. Tahaa *et al* [8] has introduced a method to improve pattern recognition and damage detection by supplementing intelligent health monitoring with used fuzzy inferences system. The Bayesian methodology is used to demarcate the levels of damage to developing the fuzzy system and is examined to provide damage identification using data obtained from finite element analysis for a pre-stressed concrete bridge. Wada *et al* [9] has proposed a fuzzy control method of triangular type membership functions using an image processing unit to control the level of granules inside a hopper. They stated that the image processing unit can be used as a detecting element and with the use of fuzzy reasoning methods good process responses were obtained. Parhi and Choudhary [10] describe a comprehensive review of various technical papers in the domain of crack detection in Beam-Like Structure. The various techniques discussed on the basis of dynamic analysis of Crack. The techniques mainly of fuzzy logic neural network, fuzzy system, hybrid neuro genetic algorithm, artificial neural network, artificial intelligence. Parhi [11] has developed a fuzzy inference based navigational control system for multiple robots working in a clumsy environment. They have been designed to navigate in an environment without hitting any obstacles along with other robots. Zimmermann [12] has applied fuzzy linear programming approach to solving linear vector maximum problem. The solutions are obtained by fuzzy linear programming. These are found to be efficient solutions then the numerous models suggested solving the vector maximum problem.

FINITE ELEMENT FORMULATION

The free bending vibration of a Euler-Bernoulli beam of a constant rectangular cross section is given by the following differential equation as given in:

$$\frac{\partial^4 \varphi(x)}{\partial x^4} - \frac{\rho \omega^2}{EI} \varphi(x) = 0 \tag{1}$$

By defining $\beta^4 = \frac{\rho \omega^2}{EI}$ equation is rearranged as a fourth order differential equation as

$$\frac{\partial^4 \varphi(x)}{\partial x^4} - \beta^4 \varphi(x) = 0 \tag{2}$$

The general solution to this equation is

$$\varphi(x) = A \sinh(\beta x) + B \cosh(\beta x) + C \sin(\beta x) + D \cos(\beta x) \tag{3}$$

Where A, B, C, D are constants and β is a frequency parameter. Adopting Hermitian shape functions, the stiffness matrix of the two-nodded beam element without a crack is obtained using the standard integration based on the variation in flexural rigidity.

The element stiffness matrix of the un cracked beam is given as

$$[K^e] = \int [B(x)]^T EI [B(x)] dx \tag{4}$$

$$[B(x)] = \{H_1(x), H_2(x), H_3(x), H_4(x)\} \tag{5}$$

Where $[H_1(x), H_2(x), H_3(x), H_4(x)]$ is the Hermitian shape functions defined as

$$H_1(x) = 1 - \frac{3x^2}{l^2} + \frac{2x^3}{l^3}, H_2(x) = x - \frac{2x^2}{l} + \frac{x^3}{l^2}, H_3(x) = 1 - \frac{3x^2}{l^2} - \frac{2x^3}{l^3}, H_4(x) = -\frac{x^2}{l} + \frac{x^3}{l^2} \tag{6}$$

Assuming the beam rigidity EI is constant and is given by EI₀ within the element, and then the element stiffness is

$$[K^e] = \frac{EI_0}{l^3} \begin{bmatrix} 12 & 6l & -12 & 6l \\ 6l & 4l^2 & -6l & 2l^2 \\ -12 & -6l & 12 & -6l \\ 6l & 2l^2 & -6l & 4l^2 \end{bmatrix} \tag{7}$$

$$[K_c^e] = [K^e] - [K_e] \tag{8}$$

Here, $[K_c^e]$ = Stiffness matrix of the cracked element, $[K^e]$ = Element stiffness matrix, $[K_e]$ = Reduction in stiffness matrix due to the crack.

According to Peng, the matrix $[K_c]$ is

$$[K_c] = \begin{bmatrix} K_{11} & K_{12} & -K_{11} & K_{14} \\ K_{12} & K_{22} & -K_{12} & K_{24} \\ -K_{11} & -K_{12} & K_{11} & -K_{14} \\ K_{14} & K_{24} & -K_{14} & K_{44} \end{bmatrix} \tag{9}$$

Where, $k_{11} = \frac{12E(I_0 - I_c)}{L^4} \left[\frac{2l_c^3}{L^2} + 3l_c \left(\frac{2L_1}{L^2} - 1 \right) \right]$

$$K_{12} = \frac{12E(I_0 - I_c)}{L^3} \left[\frac{l_c^3}{L^2} + l_c \left(2 - \frac{7L_1}{L} + \frac{6L_1^2}{L^2} \right) \right]$$

$$K_{14} = \frac{12E(I_0 - I_c)}{L^3} \left[\frac{l_c^3}{L^2} + l_c \left(2 - \frac{5L_1}{L} + \frac{6L_1^2}{L^2} \right) \right]$$

$$K_{24} = \frac{12E(I_0 - I_c)}{L^3} \left[\frac{3l_c^3}{L^2} + 2l_c \left(2 - \frac{9L_1}{L} + \frac{9L_1^2}{L^2} \right) \right]$$

$$K_{44} = \frac{12E(I_0 - I_c)}{L^2} \left[\frac{3l_c^3}{L^2} + 2l_c \left(\frac{3L_1}{L} - 1 \right) \right]$$

Here, $l_c=1.5W$, L =Total length of the beam, L_1 =Distance between the left node and crack

$I_0 = \frac{BW^3}{12}$ =Moment of inertia of the beam cross section, $I_c = \frac{B(W-a)^3}{12}$ =Moment of inertia of the beam with crack.

It is supposed that the crack does not affect the mass distribution of the beam. Therefore, the consistent mass matrix of the beam element can be formulated directly as

$$[M^e] = \int_0^1 \rho A [H(x)]^T [H(x)] dx \tag{10}$$

$$[M^e] = \frac{\rho A l}{420} \begin{bmatrix} 156 & 22l & 54 & -13l \\ 22l & 4l^2 & 13l & -3l^2 \\ 54 & 13l & 156 & -22l \\ -13l & -3l^2 & -22l & 4l^2 \end{bmatrix} \tag{11}$$

The natural frequency then can be calculated from the relation.

$$[-\omega^2 [M] + [K]] \{q\} = 0 \tag{12}$$

Where, q =displacement vector of the beam

ANALYSIS OF FUZZY MECHANISM USED FOR CRACK DETECTION

The fuzzy controller has been developed (as shown in Fig.:1) where there are 3 inputs and 2 outputs parameter.

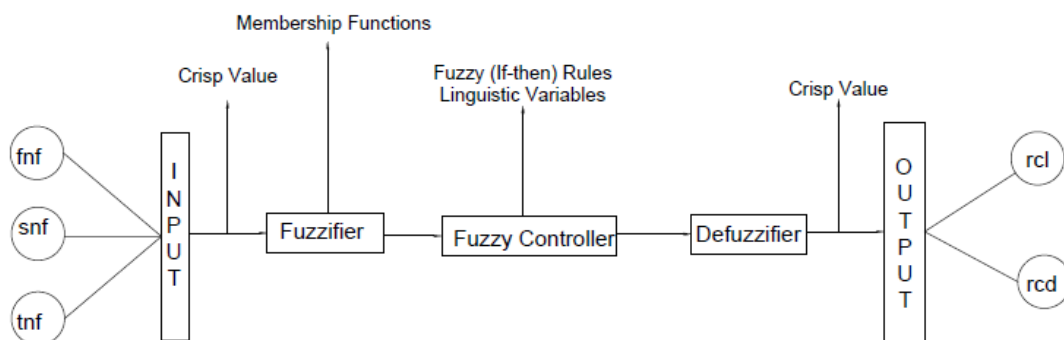

Fig. 1 Schematic Diagram of Fuzzy Inference System

The linguistic term used for the inputs are as follows;

- Relative first natural frequency = FNF
- Relative second natural frequency = SNF
- Relative third natural frequency = TNF
- Relative crack depth = RCD
- Relative crack location = RCL

The fuzzy models developed in the current analysis, based on triangular, Gaussian and trapezoidal membership functions have got three or six input parameters and two or four output parameters. The pictorial view of the triangular membership, Gaussian membership, trapezoidal membership fuzzy models are shown in Fig. 2(a), Fig. 2(b) and Fig. 2(c) respectively.

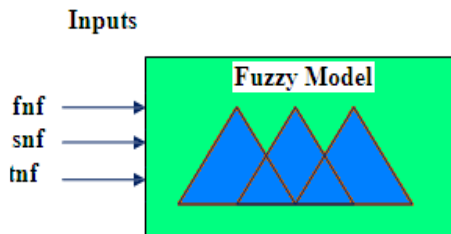

Fig. 2 (a) Triangular Fuzzy Model

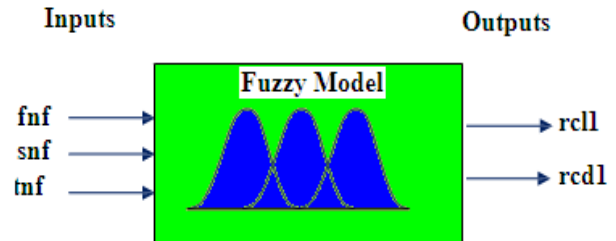

Fig. 2 (b) Gaussian Fuzzy Model

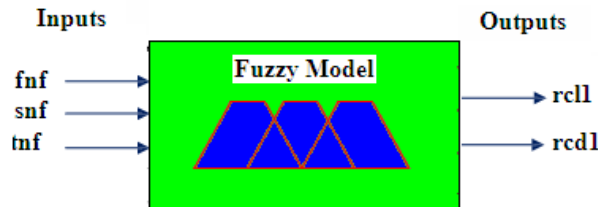

Fig. 2(c) Trapezoidal Fuzzy Model

Based on the above fuzzy subset the fuzzy rules are defined in a general form as follows: If (FNF is FNF_i and SNF is SNF_j and TNF is TNF_k) then (CD is CD_{ijk} and CL is CL_{ijk}) Where i= 1to 9, j=1 to 9, k=1 to 9 (13)
Because of “FNF”, “SNF”, “TNF” have 9 membership functions each.

From the above expression (11), two set of rules can be written

If (FNF is FNF_i and SNF is SNF_j and TNF is TNF_k) then CD is CD_{ijk} (14 a)

If (FNF is FNF_i and SNF is SNF_j and TNF is TNF_k) then CL is CL_{ijk} (14 b)

According to the usual Fuzzy logic control method (Das and Parhi [1]), a factor W_{ijk} is defined for the rules as follows:
W_{ijk}=μ_{fnfi}(freq_i) ∧ μ_{snfj}(freq_j) ∧ μ_{tnfk}(freq_k)
Where freq_i, freq_j and freq_k are the first, second and third natural frequency of the cantilever beam with crack respectively ; by Applying composition rule of interference (Das and Parhi [1,13]) the membership values of the relative crack location and relative crack depth (location)CL.

$$\mu_{rclijk}(\text{location}) = W_{ijk} \wedge \mu_{rclijk}(\text{location}) \text{ length CL}$$

$$\text{As; } \mu_{rcdijk}(\text{depth}) = W_{ijk} \wedge \mu_{rcdijk}(\text{depth}) \text{ depth CD}$$

The overall conclusion by combining the output of all the fuzzy can be written as follows:

$$\mu_{rclijk}(\text{location}) = \mu_{rcl111}(\text{location}) \vee \dots \vee \mu_{rclijk}(\text{location}) \vee \dots \vee \mu_{rcl999}(\text{location}) \tag{15a}$$

$$\mu_{rcdijk}(\text{depth}) = \mu_{rcd111}(\text{depth}) \vee \dots \vee \mu_{rcdijk}(\text{depth}) \vee \dots \vee \mu_{rcd999}(\text{depth}) \tag{15b}$$

The crisp values of relative crack location and relative crack depth are computed using the centre of gravity method (Das and Parhi [1, 13]) as:

$$\text{Relative crack loaction} = \frac{\int \text{location} \cdot \mu_{rcl}(\text{location}) \cdot d(\text{location})}{\int \mu_{rcl}(\text{location}) \cdot d(\text{location})}$$

$$\text{Relative crack depth} = \frac{\int \text{depth} \cdot \mu_{rcd}(\text{depth}) \cdot d(\text{depth})}{\int \mu_{rcd}(\text{depth}) \cdot d(\text{depth})}$$

RESULTS AND DISCUSSION

The fuzzy controller has been designed using three types of membership functions, i.e. Triangular, Trapezoidal and Gaussian membership function. The linguistic terms used for the fuzzy membership function have been specified in Table -1. The fuzzy rules being used for the fuzzy inference system are specified in the Table - 2. Out of several hundreds of fuzzy rules only twenty-four fuzzy rules have been indicated in the table. Fig. 3 to Fig. 5 shows the operation of fuzzy inference system to exhibits the fuzzy results after defuzzification when rule 2 and 15 of the Table -2 are activated for triangular, trapezoidal, Gaussian and hybrid membership functions respectively. The comparison of the results obtained from theoretical and the fuzzy controller of triangular membership function, fuzzy controller with trapezoidal membership function, fuzzy controller with Gaussian membership function are presented in Table - 3. Table - 4 shows the comparisons of natural frequencies of the beam with various crack depth and location by theoretical, ANSYS and experimental method. Graph: 1 to Graph: 4 show the natural frequencies obtained by experimental method (fft analysis).

Table -1 Linguistic Term used for Fuzzy Membership Functions

Name of the Membership functions	Linguistic terms	Description and range of the linguistic terms
L1F1,L1F2,L1F3,L1F4	fnf _{1to4}	Low ranges of relative natural frequency for first mode of vibration in ascending order respectively.
M1F1,M1F2,M1F3	Fnf _{5to7}	Medium ranges of relative natural frequency for first mode of vibration in ascending order respectively.
H1F1,H1F2,H1F3,H1F4	fnf _{8to11}	Higher ranges of relative natural frequency for first mode of vibration in ascending order respectively
L2F1,L2F2,L2F3,L2F4	snf _{1to4}	Low ranges of relative natural frequency for second mode of vibration in ascending order respectively.
M2F1,M2F2,M2F3	snf _{5to7}	Medium ranges of relative natural frequency for second mode of vibration in ascending order respectively.
H2F1,H2F2,H2F3,H2F4	snf _{8to11}	Higher ranges of relative natural frequency for first mode of vibration in ascending order respectively
L3F1,L3F2,L3F3,L3F4	tnf _{1to4}	Low ranges of relative natural frequency for second mode of vibration in ascending order respectively
M3F1,M3F2,M3F3	tnf _{5to7}	Medium ranges of relative natural frequency for second mode of vibration in ascending order respectively
H3F1,H3F2,H3F3,H3F4	tnf _{8to11}	Higher ranges of relative natural frequency for first mode of vibration in ascending order respectively
SD1,SD2,SD3,SD4	rcd _{1to4}	Small ranges relative crack depth in ascending order respectively.
MD1,MD2,MD3	rcd _{5to7}	Medium ranges relative crack depth in ascending order respectively.
LD1,LD2,LD3,LD4	rcd _{8to11}	Larger ranges of relative crack depth in ascending order respectively.
SL1,SL2,SL3,SL4	rcl _{1to4}	Small ranges of relative crack depth in ascending order respectively.
ML1,ML2,ML3	rcl _{5to7}	Medium ranges of relative crack location in ascending order respectively.
BL1,BL2,BL3,BL4	rcl _{8to11}	Bigger ranges of relative crack location in ascending order.

Table -2 Fuzzy Rules for Fuzzy Inference System

S. No	Some Examples of Fuzzy rule used in the Fuzzy Controller
1	If fnf is L1F1, snf is L2F1, tnf is L3F1 then rcd is SD1 and rcl is SL1
2	If fnf is L1F1, snf is L2F2, tnf is L3F2 then rcd is SD2 and rcl is SL2
3	If fnf is L1F1, snf is L2F2, tnf is L3F3 then rcd is SD1 and rcl is SL2
4	If fnf is M1F1, snf is M2F1, tnf is M3F1 then rcd is MD1 and rcl is ML1
5	If fnf is M1F1, snf is M2F2, tnf is M3F2 then rcd is MD2 and rcl is ML2
6	If fnf is M1F1, snf is M2F2, tnf is M3F3 then rcd is MD1 and rcl is ML2
7	If fnf is M1F2, snf is M2F1, tnf is M3F1 then rcd is MD2 and rcl is ML1
8	If fnf is M1F2, snf is M2F2, tnf is M3F2 then rcd is MD2 and rcl is ML3
9	If fnf is M1F3, snf is M2F1, tnf is M3F2 then rcd is MD3 and rcl is ML1
10	If fnf is M1F2, snf is M2F3, tnf is M3F2 then rcd is MD1 and rcl is ML3
11	If fnf is L1F2, snf is L2F1, tnf is L3F1 then rcd is SD2 and rcl is SL1
12	If fnf is L1F2, snf is L2F3, tnf is L3F3 then rcd is SD2 and rcl is SL3
13	If fnf is L1F3, snf is L2F1, tnf is L3F2 then rcd is SD3 and rcl is SL1
14	If fnf is L1F2, snf is L2F3, tnf is L3F2 then rcd is SD1 and rcl is SL3
15	If fnf is L1F3, snf is L2F3, tnf is L3F3 then rcd is SD3 and rcl is SL3
16	If fnf is M1F3, snf is M2F3, tnf is M3F3 then rcd is MD3 and rcl is ML3
17	If fnf is H1F1, snf is H2F1, tnf is H3F1 then rcd is LD1 and rcl is BL1
18	If fnf is H1F1, snf is H2F2, tnf is H3F2 then rcd is LD2 and rcl is BL2
19	If fnf is H1F1, snf is H2F3, tnf is H3F3 then rcd is LD1 and rcl is BL2
20	If fnf is H1F2, snf is H2F1, tnf is H3F1 then rcd is LD2 and rcl is BL1
21	If fnf is H1F2, snf is H2F2, tnf is H3F2 then rcd is LD2 and rcl is BL3
22	If fnf is H1F3, snf is H2F1, tnf is H3F2 then rcd is LD3 and rcl is BL1
23	If fnf is H1F2, snf is H2F3, tnf is H3F2 then rcd is LD1 and rcl is BL3
24	If fnf is H1F3, snf is H2F3, tnf is H3F3 then rcd is LD3 and rcl is BL3

Inputs for Trapezoidal Membership Function

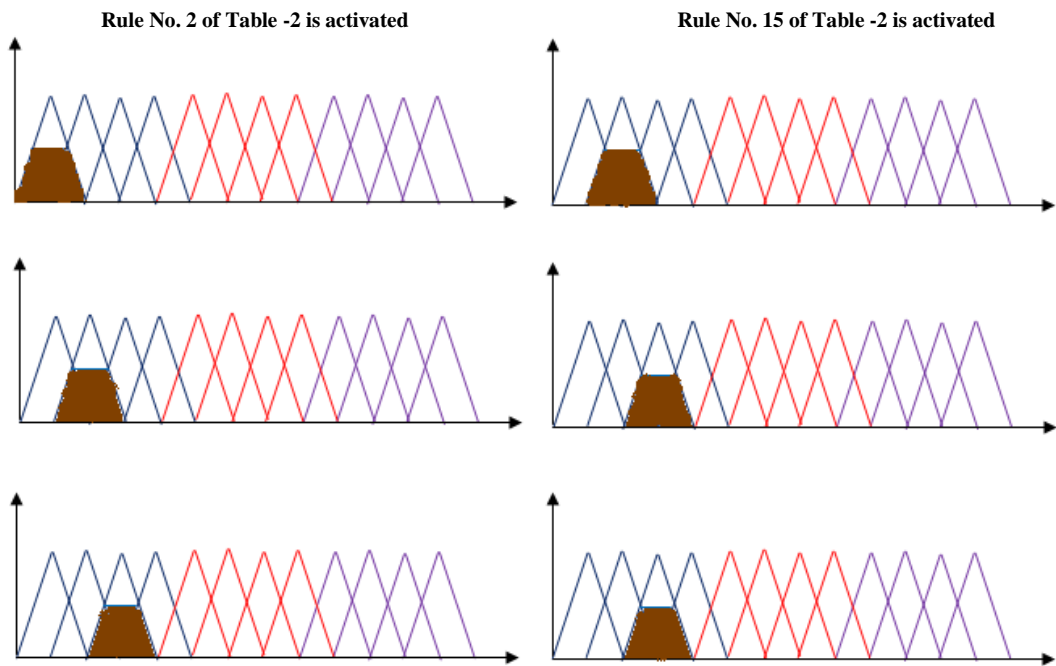

Outputs Obtained from Triangular Membership Function

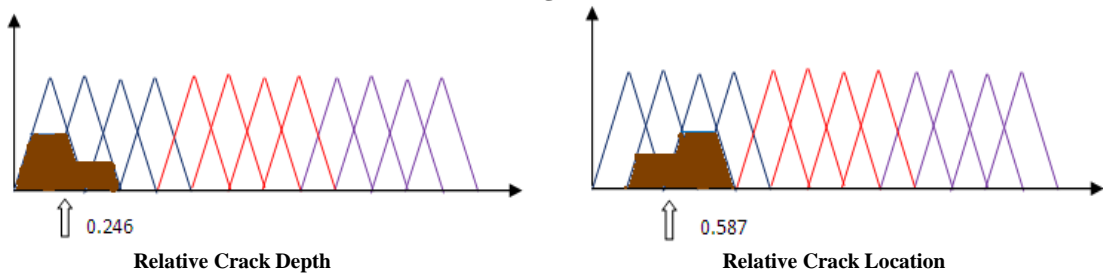
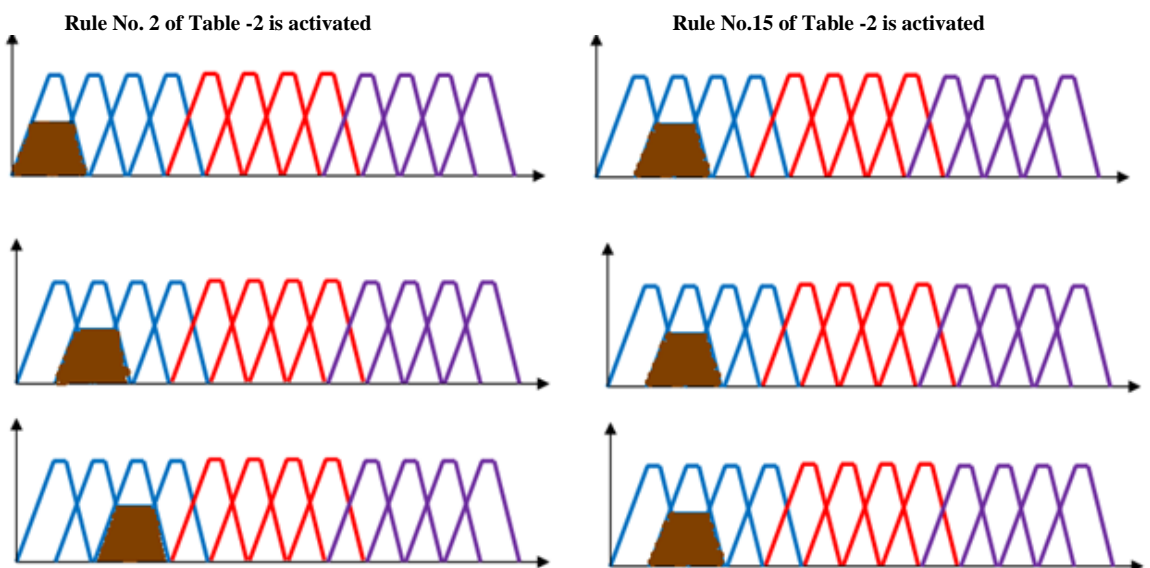

Fig. 3 Resultant Values of Relative Crack Depth and Relative Crack Location of Triangular Membership Function When Rules 2 And 15 of Table -2 Are Activated

Inputs for Trapezoidal Membership Function



Outputs Obtained from Trapezoidal Membership Function

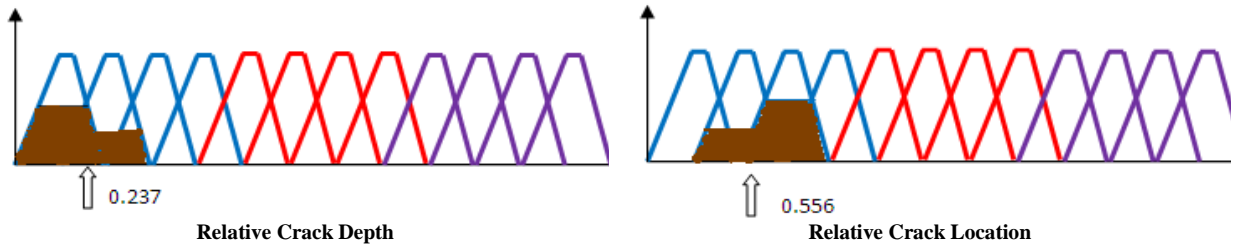
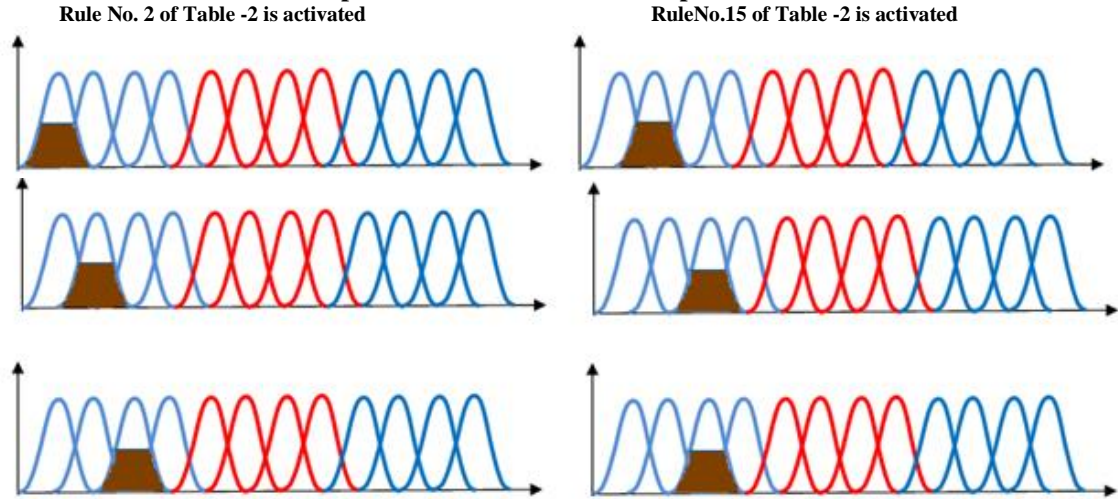

Fig. 4 Resultant Values of Relative Crack Depth and Relative Crack Location of Trapezoidal Membership Function When Rules 2 and 15 of Table -2 Are Activated

Inputs for Gaussian Membership Function



Outputs Obtained from Gaussian Membership Function

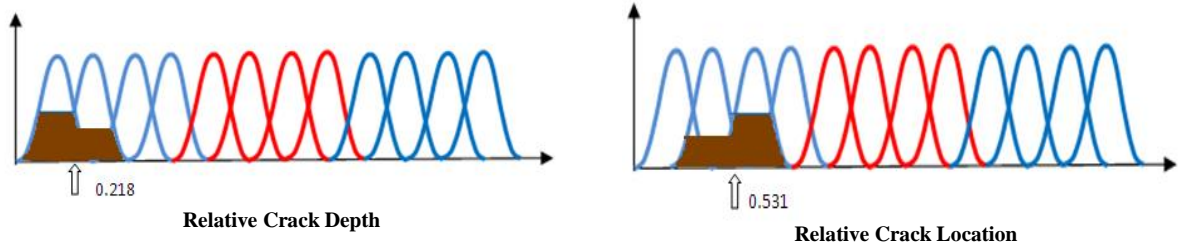
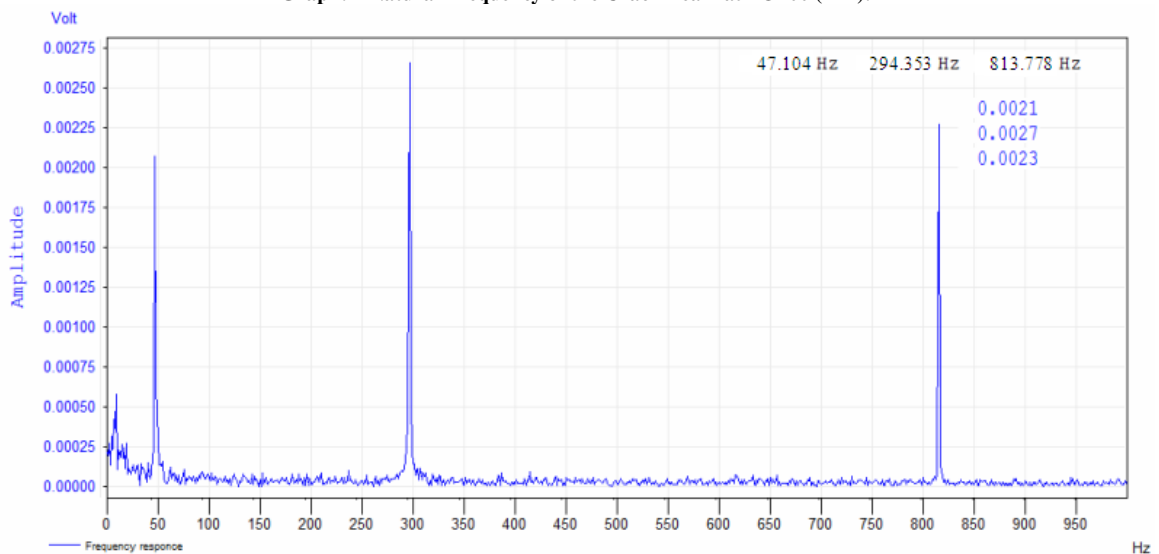
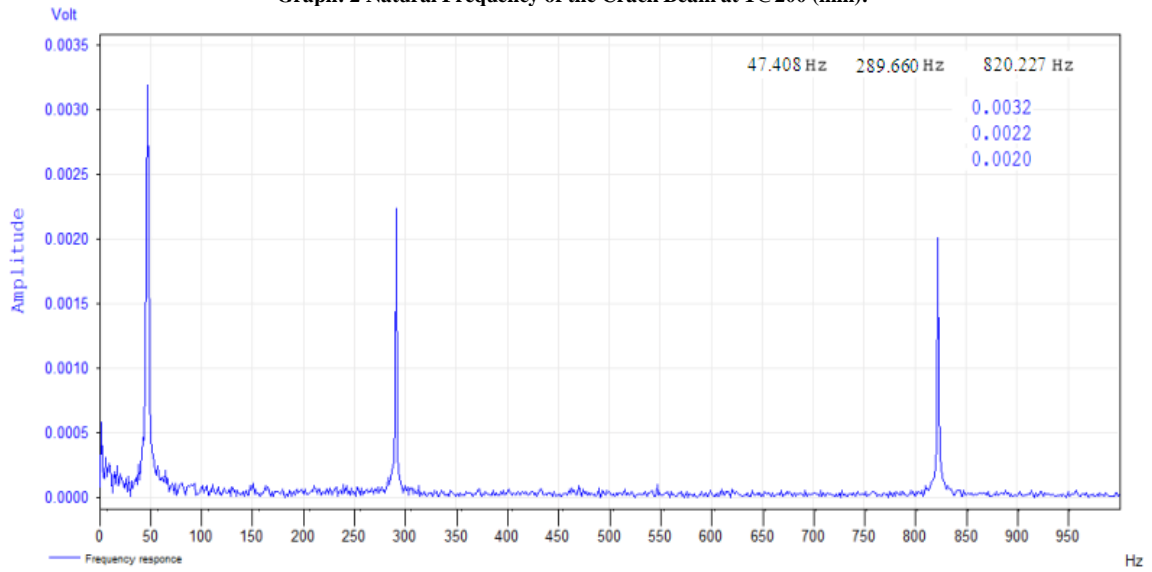

Fig. 5 Resultant Values of Relative Crack Depth and Relative Crack Location of Gaussian Membership Function When Rules 2 and 15 of Table -2 Are Activated

Graph: 1 Natural Frequency of the Crack Beam at 1@100 (mm):



Graph: 2 Natural Frequency of the Crack Beam at 1@200 (mm):



Graph: 3 Natural Frequency of the Crack Beam at 2@100 (mm)

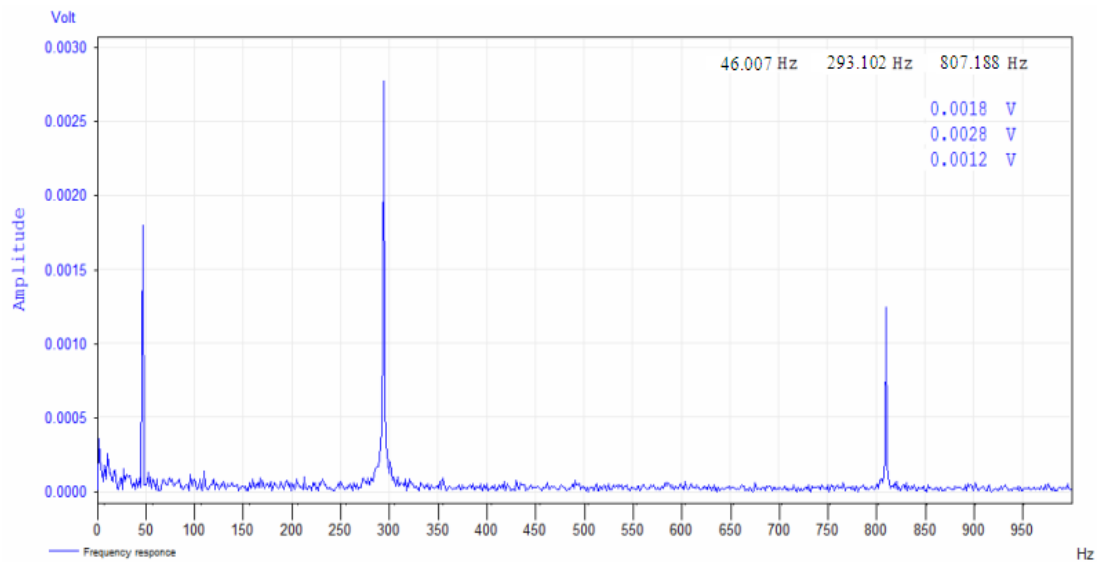

Graph: 4 Natural Frequency of the Crack Beam at 2@200 (mm)

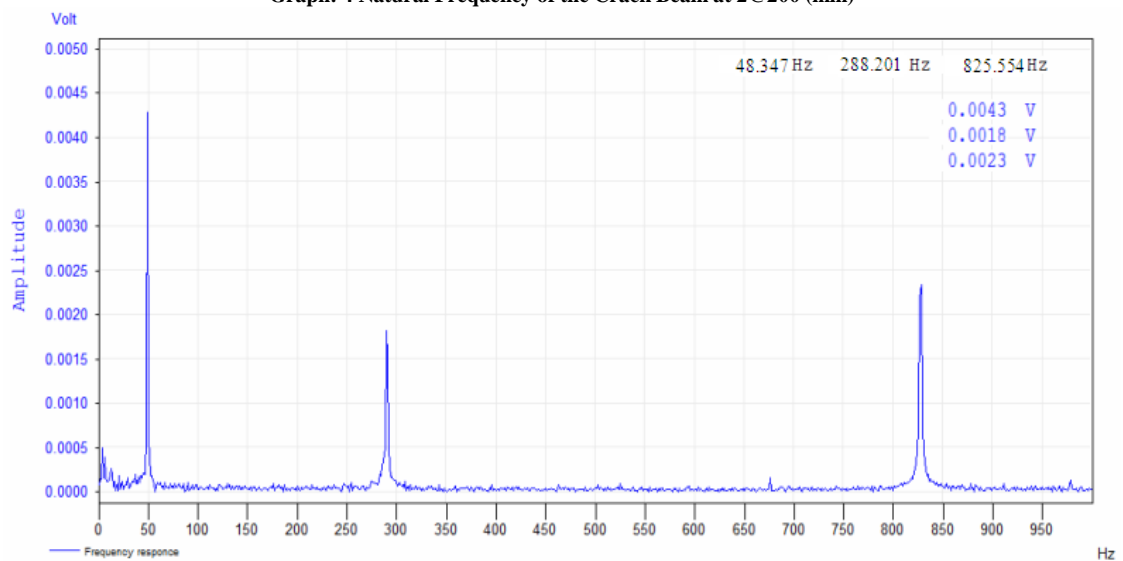

Table -3 Comparisons of Results between Theoretical Analysis and Different Fuzzy Controller Analysis

First Natural Frequency fnf	Second Natural Frequency snf	Third Natural Frequency tnf	Theoretical		Triangular Fuzzy Controller		Trapezoidal Fuzzy Controller		Gaussian Fuzzy Controller	
			Relative crack depth rcd	Relative crack location rcl	rcd	rcl	rcd	rcl	rcd	rcl
47.864	296.853	815.502	0.2	0.25	0.213	0.261	0.212	0.258	0.21	0.252
48.197	290.257	821.870	0.2	0.5	0.246	0.587	0.237	0.556	0.218	0.531
46.455	293.842	809.819	0.4	0.25	0.423	0.259	0.415	0.255	0.407	0.252
48.991	289.865	827.046	0.4	0.5	0.425	0.537	0.418	0.529	0.405	0.511

Natural Frequencies of Cantilever Beam using ANSYS For crack 1mm depth at 100 mm length

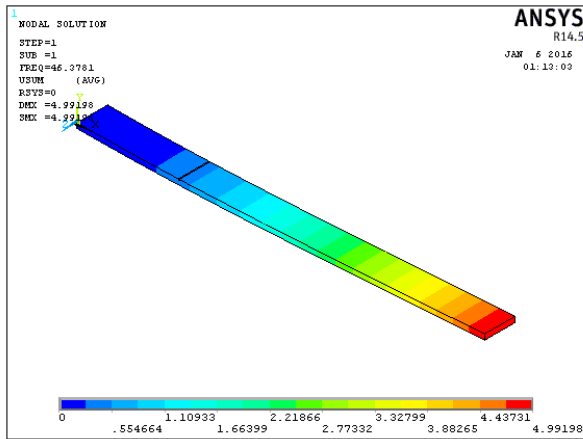

Fig. 6 (a) First Natural Frequency

For crack 1mm depth at 200 mm length

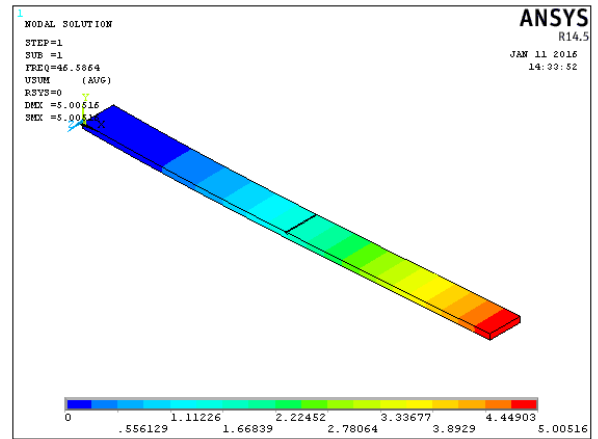

Fig. 7 (a) First Natural Frequency

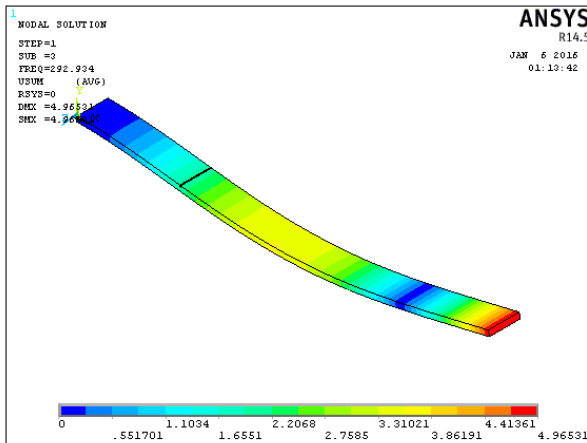

Fig. 6 (b) Second Natural Frequency

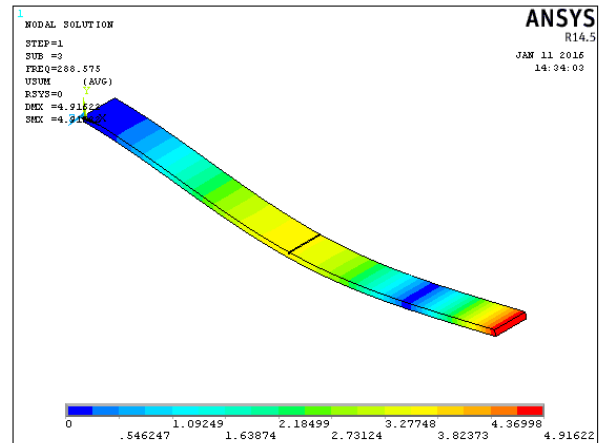

Fig. 7 (b) Second Natural Frequency

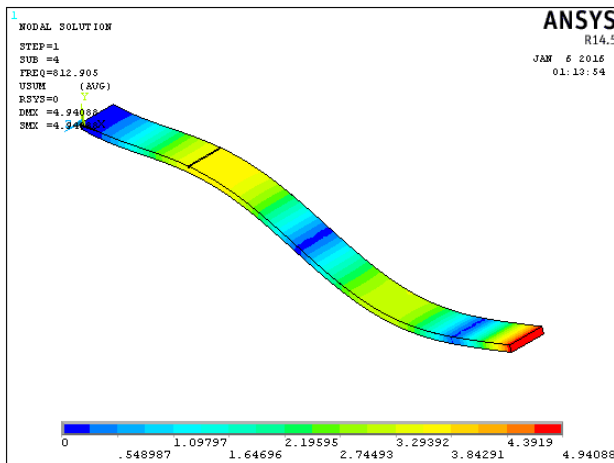

Fig. 6 (c) Third Natural Frequency

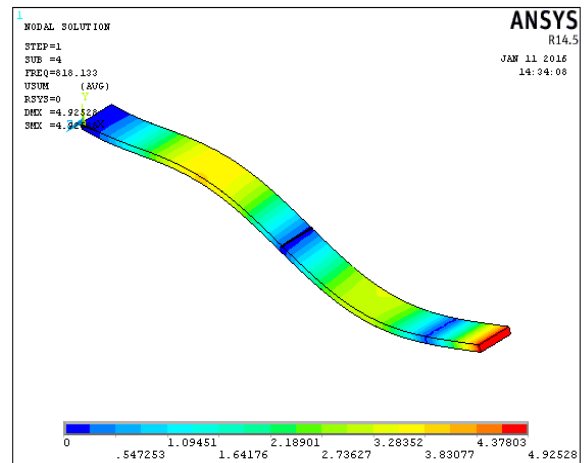

Fig. 7 (c) Third Natural Frequency

For crack 2mm depth at 100 mm length

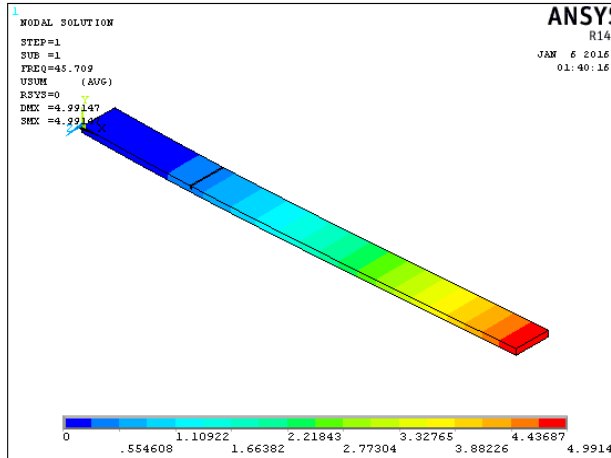

Fig. 8 (a) First Natural Frequency

For crack 2mm depth at 200 mm length

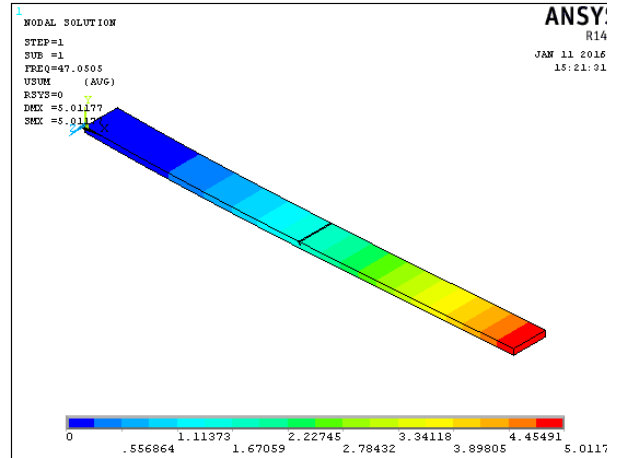

Fig. 9 (a) First Natural Frequency

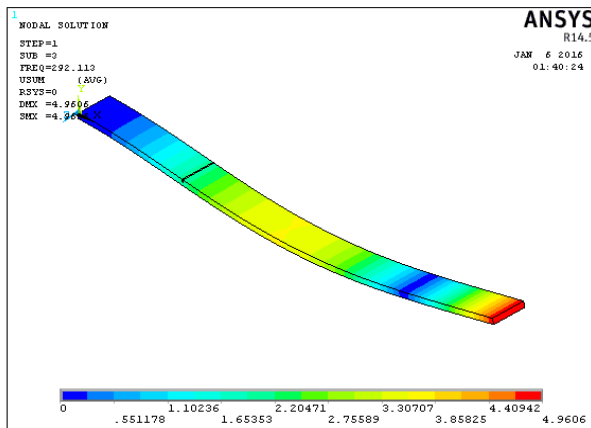

Fig. 8 (b) Second Natural Frequency

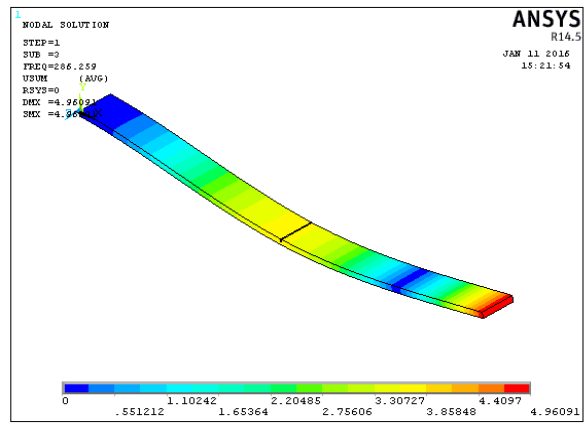

Fig. 9 (b) Second Natural Frequency

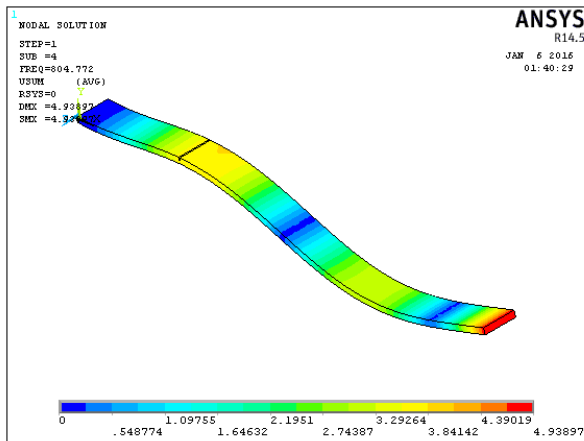

Fig. 8 (c) Third Natural Frequency

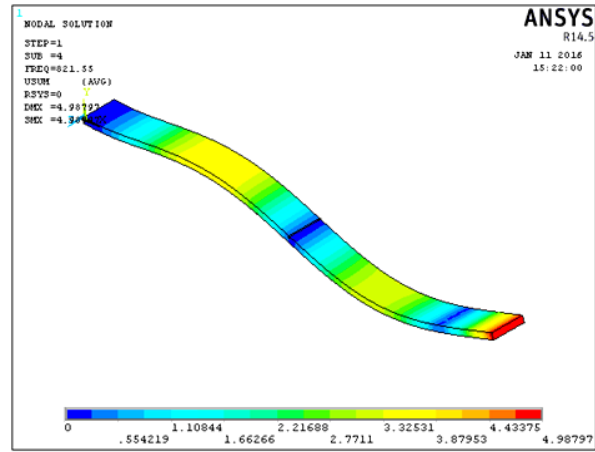

Fig. 9 (c) Third Natural Frequency

Table - 4 Natural Frequencies of Cantilever Beam

Frequency	First Natural Frequency			Second Natural Frequency			Third Natural Frequency		
	Theoretical	ANSYS	Experimental	Theoretical	ANSYS	Experimental	Theoretical	ANSYS	Experimental
Crack (mm) 1@100	47.864	46.3781	47.104	296.853	292.934	294.353	815.502	812.905	813.778
Crack (mm) 1@200	48.197	46.5864	47.408	290.257	288.575	289.660	821.870	818.132	820.227
Crack (mm) 2@100	46.455	45.709	46.007	293.842	292.113	293.102	809.819	804.772	807.188
Crack (mm) 2@200	48.991	47.0505	48.347	289.865	286.259	288.201	827.046	821.55	825.554

CONCLUSION

The fuzzy controller has been designed using Triangular, Trapezoidal and Gaussian membership function. A fuzzy controller uses three natural frequencies as inputs whereas the crack depth and crack location as output. It has been observed that the natural frequencies of the beam are changing into change in crack depth and crack location. The predicted results from fuzzy controllers of crack location and crack depth are compared with the theoretical results. It is observed from the Table -3 that the results obtained from Gaussian membership function fuzzy controller predict more accurate result in comparison to other three controllers. The cracks depth and crack location obtained from the Gaussian membership function are nearness to the theoretical value.

REFERENCES

- [1] Amiya Kumar Dash and Dayal R Parhi, Development of an Inverse Methodology for Crack Diagnosis using AI Technique, *International Journal of Computational Materials Science and Surface Engineering*, **2011**, 4(2), 143-167.
- [2] YC Huh, TY Chung, SJ Moon, HG Kil and JK Kim, Damage Detection in Beams Using Vibratory Power Estimated from the Measured Accelerations, *Journal of Sound and Vibration*, **2011**, 330(15), 3645-3665.
- [3] Dayal R Parhi and Sasanka Choudhury, Intelligent Fault Detection of a Cracked Cantilever Beam Using Fuzzy Logic Technology with Hybrid Membership Functions, *International Journal of Artificial Intelligence and Computational Research*, **2011**, 3 (1), 9-16.
- [4] Lotfi Zadeh, Fuzzy Sets and Systems, *International Journal of General Systems*, 1990, 17:2, 129-138.
- [5] A Salam, Y Alsabbagh, OM Abuzeid and Mohammad H Dado, Simplified Stress Correction Factor to Study the Dynamic Behavior of a Cracked Beam, *Applied Mathematical Modeling*, **2009**, 33, 127-139.
- [6] Deepak K Agarwalla, Abdul Sadik Khan and Subham Kumar Sahoo, Application of Genetic Fuzzy System for Damage Identification in Cantilever Beam Structure, *Procedia Engineering*, **2016**, 144, 215-225.
- [7] Dayal R Parhi and Sasanka Choudhury, Smart Crack Detection of a Cracked Cantilever Beam using Fuzzy Logic Technology with Hybrid Membership Functions, *Journal of Engineering and Technology Research*, **2011**, 3(8), 270-278.
- [8] MMR Tahaa and J Lucero, Damage Identification for Structural Health Monitoring Using Fuzzy Pattern Recognition, *Engineering Structures*, **2005**, 27, 1774-1783.
- [9] K Wada, N Hayano and H Oka, Application of the Fuzzy Control Method for Level Control of a Hopper, *Advanced Powder Technology*, **1991**, 2, 163-172.
- [10] DRK Parhi and Dash Amiya Kumar, Analysis of Methodologies Applied for Diagnosis of Fault in Vibrating Structures, *International Journal of Vehicle Noise and Vibration*, **2009**, 5 (4), 271-286.
- [11] DR Parhi, Navigation of Mobile Robot using a Fuzzy Logic Model, *Journal of Intelligent and Robotic Systems: Theory and Applications*, **2005**, 42, 253-273.
- [12] HJ Zimmermann, Fuzzy Programming and Linear Programming with Several Objective Functions, *Fuzzy Sets and Systems*, 1978, 1, 45-55.
- [13] Harish Ch Das and Dayal R Parhi, Online Fuzzy Logic Crack Detection of a Cantilever Beam, *International Journal of Knowledge-based and Intelligent Engineering Systems*, **2008**, 12 (2), 157-171.