

[14] Nonlinear filtering with adaptation to local properties of the image

Shcherbakov M.A., Panov A.P.
Penza State University

Abstract

Different approaches to construction of digital nonlinear filters using local properties of the image are offered. Structures of nonlinear filters with regulation of weight of the nonlinear component and parametric adaptation are considered. Effectiveness of proposed methods of filtering is demonstrated on examples of suppression of additive Gaussian and impulse noises.

Keywords: DIGITAL IMAGE PROCESSING, ADAPTIVE NONLINEAR FILTER, NOISE REDUCTION

Citation: SHCHERBAKOV M.A. NONLINEAR FILTERING WITH ADAPTATION TO LOCAL PROPERTIES OF THE IMAGE / SHCHERBAKOV M.A., PANOV A.P. // COMPUTER OPTICS. – 2014. – VOL. 38(4). – P. 818-824.

Introduction

Designing of nonlinear filters, which are optimal according to some criterion, relates to minimization of a functional that determines the filtration quality. In case of some other criteria being usually controversial in character, the purpose of designing is to construct Pareto optimal filters [1] which enable to achieve the minimum of the weighted quality functional. Synthesis of optimal nonlinear filters requires knowledge of higher-order correlation moments which can be a priori known or experimentally determined [2]. For filtering of signals with variable statistical properties it is possible to obtain optimum-close solutions based on local adaptive nonlinear image processing [3].

Adaptive filtering can be performed using both the input signal alone (with no feedback) and also the output signal (with a feedback). The choice of the adaptive filtering method is determined by specific character of the problem being solved. Construction of filters with input signal adaptation is based on the use of analytical methods and requires direct setting of filter's behavior depending on properties of the input signal. If it is difficult to give analytical description, output signal adaptive filters can be applied. The matching error can be used between target and output signals to correct weighting factors in the filters. Adaptive polynomial filters can be implemented both in time and frequency [4] areas, and they mainly differ from each other by their target function and the algorithm used for its minimization. In this context, the key issue in designing nonlinear feedback filters is to select the type and parameters of the algorithm.

It is generally difficult to give clear interpretation of nonlinear filters synthesized using multi-objective optimization techniques [1]. Though the resulting filter coefficients are considered to be optimal according to the selected criteria, the meaning of nonlinear filtering processes is not considered herewith. In practice, it often makes sense to sacrifice the filter's optimality to support a simpler solution with clear physical meaning.

1. Setting-up a filtering problem

Let us consider a problem of extraction of the useful signal $s(\mathbf{n})$ from the observed signal $x(\mathbf{n})$ distorted with additive noise $\xi(\mathbf{n})$:

$$x(\mathbf{n}) = s(\mathbf{n}) + \xi(\mathbf{n}),$$

where $\mathbf{n} = [n_1, n_2]$ is the vector defining point (pixel) coordinates of the image.

If the interference $\xi(\mathbf{n})$ is represented as the white noise, the estimate $\hat{s}(\mathbf{n})$ minimizing the mean-root-square error $M \{\hat{s}(\mathbf{n}) - s(\mathbf{n})\}^2$ has the following form [5]:

$$\hat{s}(\mathbf{n}) = \left(1 - \frac{\hat{D}_\xi}{\hat{D}_x} \right) \cdot x(\mathbf{n}) + \frac{\hat{D}_\xi}{\hat{D}_x} \cdot \hat{m}_x \quad (1)$$

where \hat{D}_x, \hat{D}_ξ are local estimated variances of the signal $x(\mathbf{n})$ and the noise $\xi(\mathbf{n})$, respectively; \hat{m}_x – is the local estimate of the mean value $x(\mathbf{n})$.

The estimate computing procedure (1) may be interpreted as the adaptive filtering based on local signal statistics. This can be proved as follows: at relatively smooth change of the useful signal $s(\mathbf{n})$ the estimated variances of the signal $x(\mathbf{n})$ and the noise $\xi(\mathbf{n})$ will be approximately equal, and we can consider that

$\hat{D}_\xi / \hat{D}_x \approx 1$. In this case, the filter shall compute the estimate \hat{m}_x of the mean value of the input signal providing the maximum noise cancellation. On the other hand, if the signal $s(\mathbf{n})$ is changed fast ($\hat{D}_x \gg \hat{D}_\xi$), the ratio is $\hat{D}_\xi / \hat{D}_x \approx 0$, and the filter will pass the input signal $x(\mathbf{n})$ almost unchanged. Between these two extreme situations the filter output signal is formed as a weighted sum of the input signal $x(\mathbf{n})$ with its mean value \hat{m}_x . Thus, the filter's behavior has an adaptive character and varies depending on local properties of the input signal.

2. Adaptive filtering with nonlinear component weight control

Based on this approach we can construct different structures of digital nonlinear filters differing in types of estimates used for the analysis of local signal properties and adaptation parameters. In particular, in the two-component filtering method [5] the input process $x(\mathbf{n})$ is represented as low-frequency $x_L(\mathbf{n})$ and high-frequency $x_H(\mathbf{n})$ components, and the output signal $y(\mathbf{n})$ of the filter is formed as the sum

$$y(\mathbf{n}) = x_L(\mathbf{n}) + \alpha \cdot x_H(\mathbf{n}),$$

where the adaptation parameter α is determined through local variance estimates as $1 - \hat{D}_\xi / \hat{D}_x$.

This principle may be used to filter noise images while underlining boundaries at the same time. Thus to smooth noise in homogeneous areas of the image a low-frequency filter with mask can be used

$$\mathbf{H}_1 = \{h_1(i_1, i_2)\} = \begin{bmatrix} 0.1 & 0.1 & 0.1 \\ 0.1 & 0.2 & 0.1 \\ 0.1 & 0.1 & 0.1 \end{bmatrix} \quad (2)$$

whereas to contrast image details a quadratic differentiating filter can be used [6].

In general case, the filter output signal $y(\mathbf{n})$ is formed as the sum of linear $y_L(\mathbf{n})$ and nonlinear $y_N(\mathbf{n})$ components $y(\mathbf{n}) = y_L(\mathbf{n}) + \alpha \cdot y_N(\mathbf{n})$.

Depending on local properties of the image (a background or a difference) the parameter α should enhance or weaken the impact of the filter nonlinear component. In order to ensure such behavior we shall use the local estimated variance \hat{D}_x in the area of 3×3 and determine the adaptation parameter α as follows:

$$\alpha = \begin{cases} 0, & R < a; \\ \frac{\gamma(R-a)}{b-a}, & a \leq R \leq b; \\ \gamma, & R > b, \end{cases} \quad (3)$$

where γ is the amplification factor, a and b are threshold values, and the value R is selected as being equal to $\hat{D}_x / \hat{D}_\xi - 1$ and may be considered as the signal-to-noise ratio estimate.

According to (3) and the filtering circuit given in Fig. 1, such structure will execute low-pass linear filtering, when $R < a$, ensuring noise smoothing in homogeneous image areas, and high-frequency nonlinear filtering, when $R > b$, underlining boundaries of image details. Within the interval $a \leq R \leq b$ the weighted signal summation of linear and nonlinear branches will produce some averaged effect.

We can define filter nonlinearity nature by changing threshold values a and b . Convergence of thresholds leads to "tougher" nonlinearity. In the limiting case $a = b$ the nonlinear characteristic will take the form of a step function that corresponds to the instant nonlinearity "turning-on" mode when exceeded by the signal-noise ratio of the given threshold.

In addition to threshold values in the filter structure it is also proposed to set the noise variance $\xi(\mathbf{n})$. If this value is a priori unknown, its estimate may be calculated according to image homogeneous areas or may be experimentally selected in accordance with series of tests during the filtering process.

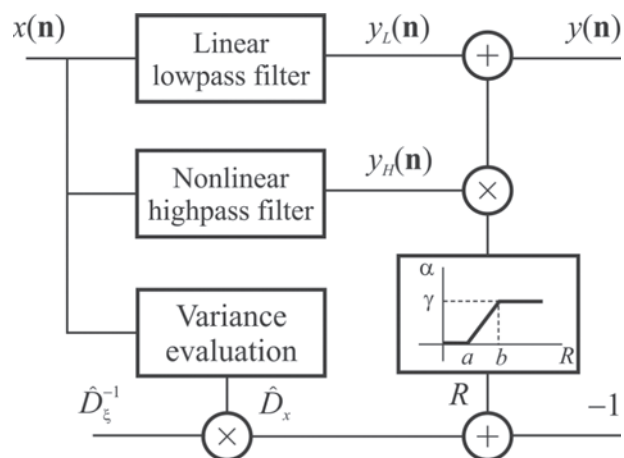

Fig. 1. Adaptive nonlinear filter with nonlinear component weight control

In order to study possibilities of the proposed filter we have used the "House" image shown in Fig. 2a. As the input we used the image given in Fig. 2b and obtained by adding Gaussian noise with the variance $D_\xi = 900$. The adaptive nonlinear filter has been used for filtering of this image with the following parameters: $\gamma = 0.001$, $a = 0$, $b = 1$. The obtained result is given in Fig. 2d. If compared, Fig. 2c shows the image obtained by normal linear filtering with mask (2). Clarity of the image obtained by nonlinear filtering is much higher. At the same time, if compare image homogeneous areas shown in Fig. 2c and d (for example, the sky or the shady side of the house), it could be seen that adaptive nonlinear filtering provides the same noise smoothing as linear filtering.

3. Nonlinear filtering with parametric adaptation

Let us discuss now another simple but rather effective way of nonlinear filtering based on the use of linear filters with parametric adaptation. We will explain the meaning of the proposed approach first using the one-dimensional case. Suppose that $h(i)$ is the impulse characteristic of the low-pass filter with the duration $N = 2M + 1$, so that $h(-M) + \dots + h(0) + \dots + h(M) = 1$. We will generate the filter output signal according to the following equation:

$$y(n) = (1 - \alpha_n \cdot \delta) \cdot x(n) + \alpha_n \cdot \sum_{\substack{i=-M \\ i \neq 0}}^M h(i) \cdot x(n-i) \quad (4)$$

where $\delta = 1 - h(0)$, and α_n is the adaptation parameter, $-1 \leq \alpha_n \leq 1$.

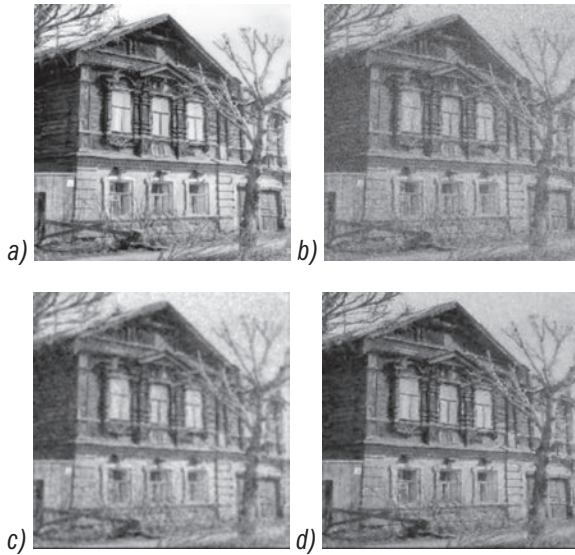

Fig. 2. Results of filtering the "House" image: (a) the initial image; (b) the image distorted by adaptive Gaussian noise with the variance $D_\xi = 900$; (c) resulted low-frequency linear filtering; (d) resulted adaptive nonlinear filtering

If the parameter $\alpha_n = 1$, the equation (4) will correspond to the low-pass linear filter, and if $\alpha_n = -1$, it will correspond to the high-pass filter; and when $\alpha_n = 0$, the input signal will be transferred without change thereof. Determining properly the adaptation parameter α , we can change the filter's behavior depending on local properties of the input signal.

Let us suppose that it's required to provide filtering of the impulse signal from broadband noise without edges distortion. In this case the filter must change its behavior showing low-frequency properties in plateau areas to change the input signal and high-frequency properties when detecting differences. It is possible to determine a difference moment, for example, by the following estimate:

$$\theta_n = [x(n+M) - x(n-M)]^2 \quad (5)$$

which is close to zero when slowly changing the signal in the vicinity of current input reading and rises sharply in difference moments. In order to convert the value θ_n into the adaptation parameter α_n , it should be reduced to the interval $[-1, 1]$. Let us use for this purpose the following function:

$$\alpha_n = f(\theta_n) = \frac{2}{1 + \gamma \cdot \theta_n} - 1 = \frac{1 - \gamma \cdot \theta_n}{1 + \gamma \cdot \theta_n} \quad (6)$$

By using the coefficient γ in (6), which changes the function scale along the X-axis, the filter may be adjusted within the specified dynamic range of the input signal. If $\theta_n = 1/\gamma$, the filter gain is equal to unity; whereas if θ_n is decreasingly deviated from this value, low-frequency properties of the adaptive filter will appear, and when it is increasingly deviated – high-frequency properties.

Another possible option of conversion of θ_n to the adaptation parameter α_n is the piece-linear function

$$\alpha_n = \begin{cases} 1, & \theta_n < a; \\ \frac{2\theta_n - a - b}{b - a}, & a \leq \theta_n \leq b; \\ -1, & \theta_n > b, \end{cases}$$

where the preliminary filter adjustment for the specified dynamic range is performed by changing threshold values a and b .

In addition to simplest difference detecting in the form of the above estimate (5), and in order to form the adaptation parameter α_n , some more complicated nonlinear structures, particularly, neural networks, may also be used. In particular, we may use the following structure for differences detection in noisy images

$$\theta_n = f \left(\sum_{i=-M}^M w_i \cdot x_i + \sum_{i=-M}^M \sum_{j=-M}^M w_{ij} \cdot x_i \cdot x_j - \theta \right),$$

where $f(\cdot)$ is the activation function varying within the range of $[-1, 1]$. Weighted coefficients shall be determined in such structures by means of training in accordance with series of test cases.

In the performed experiment we have examined the adaptive nonlinear filter whose flowchart is shown in Fig. 3. The equations (5) and (6) have been used in order to determine differences. The input signal was represented as a unit jump distorted by adding Gaussian noises with the mean-square deviation $\sigma = 0.1$.

The response on this adaptive filter signal with the impulse characteristic length $N = 11$ and the coefficient $\gamma = 1$ is shown in Fig. 4, and it differs in rather good noise suppression with no notable distortion of the impulse front.

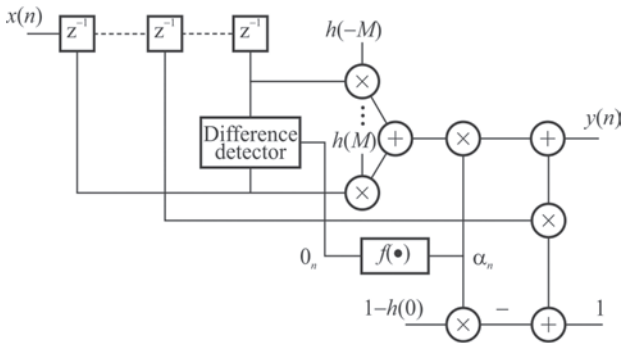

Fig. 3. Adaptive nonlinear filter flowchart

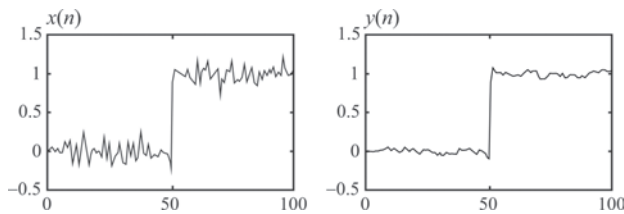

Fig. 4. Response to noisy unit jump

The proposed structure may be used for adaptive image filtering in two different ways. In the first method the general model is fully maintained, the only difference being that instead of the one-dimensional difference detector we use the two-dimensional one. We can use as such operator, for example, the Sobel operator [7] or the synthesized in [8] optimized difference detector which is resistant to noises. Thus, for example, when selecting the low-frequency filter mask in the above form (2), we will receive the following two-dimensional filtering algorithm:

$$y(n_1, n_2) = (1 - 0.9\alpha_{n_1, n_2})x(n_1, n_2) + 0.1\alpha_{n_1, n_2} \sum_{i=-1}^1 \sum_{j=-1}^1 x(n_1 - i, n_2 - j), \quad (7)$$

where the adaptation parameter is $\alpha_n = f(\theta_n)$, and θ_n – is the squared filter output signal with coefficients. The second method is based on one-dimensional processing of the two-dimensional signal along different directions and then summing the results obtained. To explain this approach we shall construct, for example, the adaptive two-dimensional filter with mask $N \times N$, $N = 2M + 1$, using an arithmetic mean operator to reduce noise and the equation in the form of (5) – to determine differences. Processing of the two-dimensional signal shall be performed in four basic directions using a pair of indexes (i, j) in the following way: $(0, 1)$ – horizontal; $(1, 0)$ – vertical; $(1, 1)$ – right diagonal; $(-1, 1)$ – left diagonal.

Based on (4), after substitution $h(n) = 1/N$, the filtering algorithm in the direction of (i, j) shall obtain the following form:

$$y_{(i,j)}(n_1, n_2) = (1 - \alpha_{(i,j), n_1, n_2})x(n_1, n_2) + \frac{\alpha_{(i,j), n_1, n_2}}{N} \sum_{k=-M}^M x(n_1 + i + k, n_2 + j + k) = x(n_1, n_2) - \frac{\alpha_{(i,j), n_1, n_2}}{N} \times \left(Nx(n_1, n_2) - \sum_{k=-M}^M x(n_1 + i + k, n_2 + j + k) \right). \quad (8)$$

Here, $\alpha_{(i,j), n_1, n_2} = f(\theta_{(i,j), n_1, n_2})$ and it can be represented as the adaptation parameter in the direction of (i, j) , where $\theta_{(i,j), n_1, n_2}$ – is the response of the difference detector in the same direction equal to

$$\theta_{(i,j), n_1, n_2} = [x(n_1 + i + M, n_2 + j + M) - x(n_1 + i - M, n_2 + j - M)]^2.$$

The filter output signal $y(n_1, n_2)$ is the sum of components (8) calculated in various directions.

$$y(n_1, n_2) = y_{(0,1)}(n_1, n_2) + y_{(1,0)}(n_1, n_2) + y_{(1,1)}(n_1, n_2) + y_{(-1,1)}(n_1, n_2). \quad (9)$$

In general, when forming each response filter component (9) in the functions $f(\theta_{(i,j), n_1, n_2})$, various coefficients γ (or the thresholds a and b) can be used for different filtering directions that enables to take into account a priori image information. For example, high-frequency properties of the filter can be amplified in a diagonal direction and low-frequency properties to be amplified in a horizontal direction, etc.

In order to compare the analyzed adaptive nonlinear filters we used the synthesized test image 60×60 in size shown in Fig. 5a and consisting of the line with 3 pixels in thickness oriented in different directions. The incoming image shown in Fig. 5b was formed from the initial image by adding normal noise with the estimated variance $\sigma^2 = 400$.

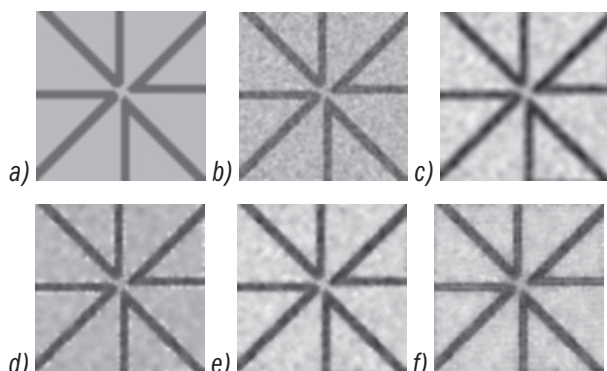

Fig. 5. Results of processing the test image using different filters: (a) the initial image; (b) the image distorted with Gaussian noise with the estimated variance $\sigma^2 = 400$; (c) resulted linear filtering with mask 3×3 ; (d, e, f) resulted adaptive processing by different nonlinear filters

The resulted linear low-pass filtering of the given image with mask (2) is shown in Fig. 5*b* which is characterized with blurring of boundaries; the result is that due to the halo effect the line thickness is increased up to 5 pixels. Fig. 5*d* shows the resulted adaptive processing by means of the nonlinear filter with weight control of the nonlinear component (see Fig. 1) with mask 3×3 and the parameters: $\gamma = 0.001$, $a = 0$, $b = 1$. Fig. 5*e* shows the image obtained as a result of processing by the nonlinear filter of the above form (7), which uses, in the capacity of the difference detector, a noise-resistant nonlinear operator with coefficients and is synthesized in [8]. And, finally, Fig. 5*f* shows the result obtained by the nonlinear filter of the above form (9) based on separate filtering in accordance with directions with mask $N = 5$ in size. In order to form the adaptation parameter we used the foregoing function (6), and the coefficient γ was selected in accordance with the noise level.

As can be seen from the above figures, though the details of nonlinear processing effects are slightly different from each other, all nonlinear filters can reduce the noise level while retaining the difference

boundaries. The biggest noise reduction can be observed in Fig. 5*d* and *e*, while the line density is higher in Fig. 5*f*. Some distortions of image elements directly adjacent to difference boundaries are typical for Fig. 5*d*, *e*, though to a smaller extent than in linear processing. The distortions will increase with the increase of mask size. These distortions are practically absent in Fig. 5*f* that can be explained by separate adaptation of the filter to local properties of the image in different directions.

The example of filtering of noisy images is shown in Fig. 6. We used the "Castle" image (Fig. 6*a*) distorted by Gaussian noise with the estimated variance $\sigma^2 = 500$ (Fig. 6*b*) as the input image. Results of linear filtering with mask (3) and the adaptive nonlinear filtration in the above form (9) with the value $N = 5$ are shown in Fig. 6*c* and *d*. The adaptation parameter was formed in accordance with the above equations (5), (6). It is evident from comparing the given results that the quality of the image after nonlinear processing is much higher and has a higher degree of noise reduction and clarity of image details.

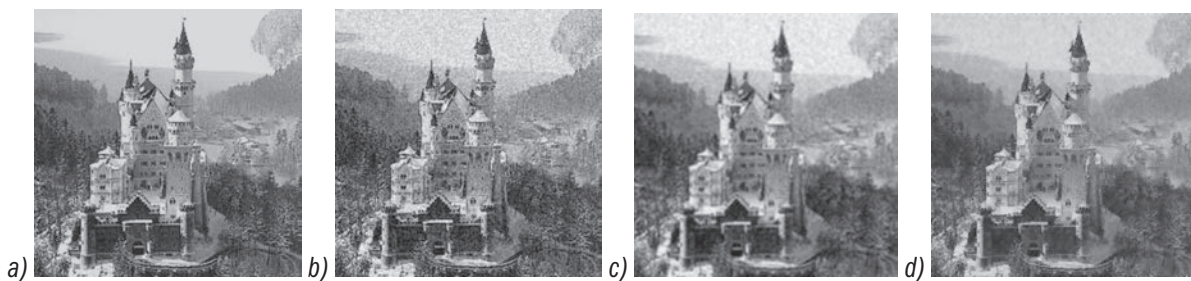

Fig. 6. Results of filtering the "Castle" image: (a) the initial image; (b) the image distorted with Gaussian noise with the estimated variance $s_2 = 500$; (c) the resulted low-frequency linear filtering with mask 3×3; (d) the resulted adaptive nonlinear filtration of the form (9) with mask $N = 5$ in size

The analyzed principle of adaptive filtering can be used not only for noise reduction with a continuous probability distribution function but also for various kinds of impulse noise occurring, for example, as a result of decoding errors in the image transfer process over communication channels. They appear in the form of brightness emissions of individual pixels of the image. The distorted image is well described by the above model [5].

$$x(\mathbf{n}) = \begin{cases} \Delta_{\xi} & , \text{ with probability } \delta; \\ s(\mathbf{n}) & , \text{ with probability } 1 - \delta, \end{cases} \quad (10)$$

where Δ_{ξ} – is the value of brightness (noise) emissions.

In order to suppress this type of interferences, median filtering is generally used [5, 7]. It is based on ordering of image elements in ascending order and ex-

tracting of a mean from the obtained range. Median filtering is a more effective mean in impulse distortion suppression than normal averaging since it allows maintain the clarity of image details. The window size of the median filter should be selected twice as much as the impulse width that will provide single-impulses suppression. In the case of impulse merging the median filter does not guarantee their elimination. The filter mask size should be increased to eliminate these interferences. However, this shall inevitably lead to blurring of boundaries of image details. Median filtering involves processing of the entire image replacing a current image element with the median value regardless of whether it is distorted or not. The result is that such filtering does not only eliminate impulse noises, but also introduces distortions into true image elements.

in the proposed below adaptive nonlinear filtering scheme shown in Fig. 7, the correction is performed only in case of distorted image element. If the filter mask size is $N \times N$, $N = 2M + 1$ (in the figure $N = 3$), the output signal shall be determined by the following equation:

$$y(n_1, n_2) = (1 - \alpha_{n_1, n_2}) \cdot x(n_1, n_2) + \frac{\alpha_{n_1, n_2}}{N^2 - 1} \cdot \sum_{\substack{i=-M \\ i \neq 0}}^M \sum_{\substack{j=-M \\ j \neq 0}}^M x(n_1 - i, n_2 - j). \quad (11)$$

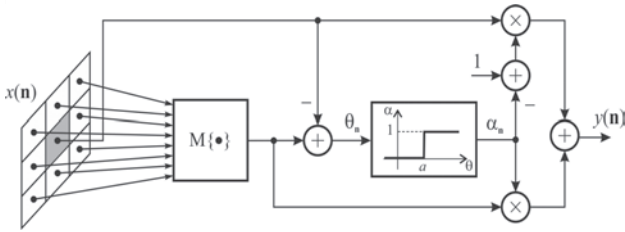

Fig. 7. Adaptive nonlinear filter flowchart for impulse noise suppression

The following estimate is used here for detection of the impulse noise:

$$\theta_n = \theta_{n_1, n_2} = x(\mathbf{n}) - \frac{1}{N^2 - 1} \cdot \sum_{\substack{i=-M \\ i \neq 0}}^M \sum_{\substack{j=-M \\ j \neq 0}}^M x(n_1 - i, n_2 - j), \quad (12)$$

which represents the deviation of the current element $x(\mathbf{n})$ from the mean value of image elements located in its neighborhood $N \times N$ in size. The filter adaptation parameter α_n possessing discrete values 0 and 1 is formed as follows:

$$\alpha_n = f(\theta_n) = \begin{cases} 1, & \theta_n > a; \\ 0, & \theta_n \leq a. \end{cases}$$

If the value θ_n exceeds the given threshold a ($\alpha_n = 1$), the element $x(\mathbf{n})$ shall be classified as an interference and can be replaced with the mean value of its surrounding elements. Otherwise ($\alpha_n = 0$), the element $x(\mathbf{n})$ shall be transferred unchanged to the filter output.

In case of severe image distortions and residual interferences, the obtained image may be processed once more after filtering performed with a lower threshold a . The phased threshold reduction from-stage-to-stage enables to minimize the effect of blurring image details. There usually happen to be good results already after two or three stages of image processing.

Filtering examples of impulse noises are shown in Fig. 8. The image "Lena" distorted according to (10), when $p = 0.2$ and $\Delta_\xi = 250$, is shown in Fig. 8a. The image processing effect using the median filter with mask 3×3 in size is given in Fig. 8b and is characterized by residual noises and distortions forming a slightly stylish look in it.

These distortions are amplified by increasing the size of the median filter mask. Fig. 8c shows the image obtained as the result of adaptive nonlinear filtering according to (11) with the threshold $a = 70$. If compared with median filtering, the noise level is significantly lower here, and the nature of residual distortions is smoother. In order to reduce these distortions the resulting image was processed again by the adaptive filter with the lower threshold value $a = 30$. The result is that we have obtained the image shown in Fig. 8d, in which impulse noises are practically absent, and distortions associated with some decrease in image clarity are lower than in the case of median filtering.

Conclusion

Therefore, the proposed structures and principles of construction of digital nonlinear filters with adaptation to local properties of the input signal are characterized by the simplicity and the ability to control the process of nonlinear filtration with a small number of parameters that makes it possible to use them in solving various problems of digital image processing so as to obtain predictable visual filtering results.

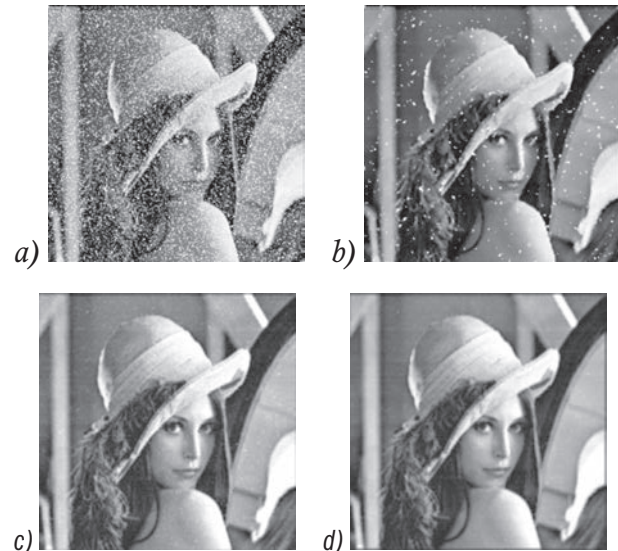

Fig. 8. Results of filtering the image "Lena": (a) the impulse-noise distorted image with the probability value $p = 0.2$; (b) the result of median filtering with mask 3×3 in size; (c, d) the results of phased nonlinear filtering with threshold values a , and equal to 70 and 30, respectively

Acknowledgements

This work has been performed with the support of the Ministry of Education and Science of the Russian Federation within the framework of the state task in the field of research and development activities.

References

1. **Shcherbakov, M.A.** Designing Pareto Optimal Nonlinear Filters for Image Processing / M.A. Shcherbakov // Automation and Remote Control. – 2010. – Vol. 71(2). – P. 339-351.
2. **Shcherbakov, M.A.** Iterative method of optimal nonlinear filtering of images / M.A. Shcherbakov // University proceedings. Volga region. Technical sciences. – 2011. – Vol. 4(20). – P. 43-56. (in Russian).
3. **Kopenkov, V.N.** An algorithm for automatic construction of computational procedure of non-linear local image processing on the base of hierarchical regression / V.V. Myasnikov // Computer Optics. – 2012. – Vol. 36(2). – P. 257-265. (in Russian).
4. **Shcherbakov, M.A.** Proceedings of 6th Saint Petersburg Symposium on Adaptive Systems Theory / M.A. Shcherbakov // Proceedings of 6th Saint Petersburg Symposium on Adaptive Systems Theory. – 1999. – Vol. 2. – P. 195-197. (in Russian).
5. **Pitas, I.** Nonlinear digital filters: principles and applications / I. Pitas, A.N. Venetsanopoulos. – Boston: Kluwer Academic Publishers. – 1990. – P. 391.
6. **Shcherbakov, M.A.** Method for the synthesis of digital polynomial filters using basis frequency functions / M.A. Shcherbakov, S.V. Sorokin // University proceedings. Volga region. Technical sciences. – 2007. – Vol. 4. – P. 74-86. (in Russian).
7. **Pratt, W.** Digital image processing (in 2 books). – Wiley-Interscience: John Wiley & Sons, Inc., Publication. – P. 786.
8. **Shcherbakov, M.A.** A matrix solution of the problem of optimal nonlinear image filtering / M.A. Shcherbakov, S.V. Sorokin // Reliability and quality: Proceedings of the International Symposium. – Penza: PSU Publisher. – 2007. – Vol. 1. – P. 285-288. (in Russian).

