

INVESTIGATION OF VIBRATORY LOADINGS OF MOTOR VEHICLE'S USER IN OPERATION CONDITIONS

Miroslav Demić¹, Ph.D, Full professor, Jovanka Lukić, Ph.D, Full professor, Živorad Milić, Phd,ME

UDC: 629,18; 534,1;614,872;629.1.07

1. INTRODUCTION

Investigations of a human body exposed to vibratory loads are significant in vehicle design. It enables modelling and parameters optimisation of vehicles from ride comfort aspects. In order to obtain reliable laboratory conditions experiment in operational conditions are conducted. Passangers and trucks are used in experimental conditions.

Users of vehicles are exposed to broadband random vibration in longitudinal, lateral and vertical directions, as well as angular oscillatory loads. Field experiments are conducted in the first phase of investigations in order to get data about dominant vibratory loads of human in motor vehicle.

The influence of vertical vibration on human is analysed in significant number of published papers, because oscillatory loads are highest in vertical direction [4,15-16]. The influence of the multi-axial vibrations is not investigated in such number of papers. In order to determine the influence of multi-axial vibrations on human it was necessary to rang vibratory load directions in passenger cars and trucks in operational conditions. Field experiments were conducted.

2. EXPERIMENTAL RESEARCH OF ACTUAL VIBRATORY LOADS OF HUMAN IN VEHICLES

Data about dominant vibratory loads of passengers are important for parameter identification of ride comfort of vehicle. Field experiments are conducted in operational conditions. Accelerations in three orthogonal directions are measured (fore and aft x , lateral y and vertical z), according to [18-20] on seat and floor of the vehicle in order to determine dominant vibratory loadings of passengers. Inductive accelerometers HBM B12/200, amplifier HBM DMC 100 and data acquisition software BEAM 3.1 (Apple Macintosh operating system) are used. Each record lasted $T=27.33$ s, number of data points was $n=2048$ and data acquisition step was $\Delta t=1.33*10^{-3}$ s. Spectral analysis was performed in the frequency domain of 0.09-37.5 Hz. Each factor level was repeated $N=5$ times.

Experiments were performed on good and bad asphalt road. Acceleration signals in "good asphalt conditions" are recorded on straight-line section of road Kragujevac-Batočina. Accelerations signals in "bad asphalt conditions" are conducted on flat horizontal section of "old road" Kragujevac-Batočina between Maršić i Korman turns. Lane had small number of holes.

Different types of passenger cars were used: Yugo 65 cl, Florida equipped with standard vehicles suspension system, Florida equipped with prototype of new suspension

¹ Miroslav Demić, University of Kragujevac, Faculty of Engineering, demic@kg.ac.rs

system and Fiat Croma, as well trucks: Rival, Turbo Zeta and Euro Cargo. All vehicles both passengers and trucks were new.

Measurements were conducted in three speed regimes: 30, 60 and 90 km/h. Vehicle's speeds was constant.

Trucks were loaded and unloaded and had speed 30, 50 and 70 km/h on good and bad asphalts.

Chosen roads represent road network in Serbia and chosen speeds are adapted to road conditions. Time series of accelerations are recorded under constant speed conditions in order to get stationary ergodic random process.

Computer memory limitation caused repeating of measuring five times and total time signal was 135 s. Recorded time signals of accelerations are analysed by using of Macintosh Powerbook 150 and software BEAM.

Accelerometers measuring positions were on the floor below seat and on the seat cushion of assistant driver are given in figure 1. The measuring points were the same both passenger cars and trucks. Measurement set up is given in figure 2.

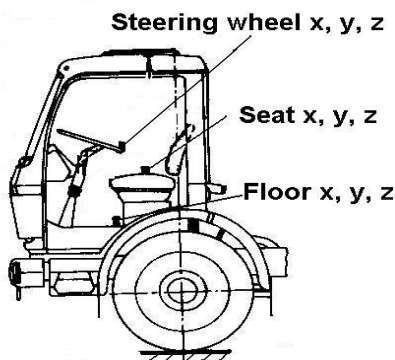

Figure 1 Measuring points

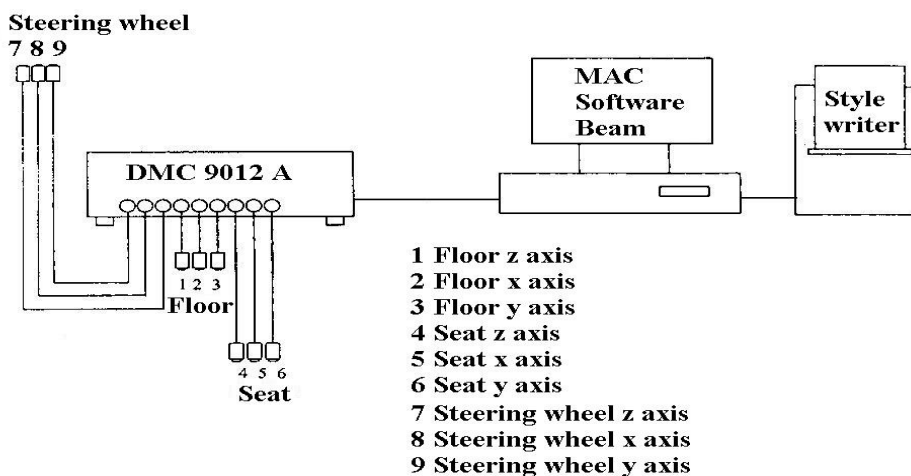

Figure 2 Measurement set up

Time series of accelerations measured in vehicle 4910H on different roads are random signals and are given in figure 3.

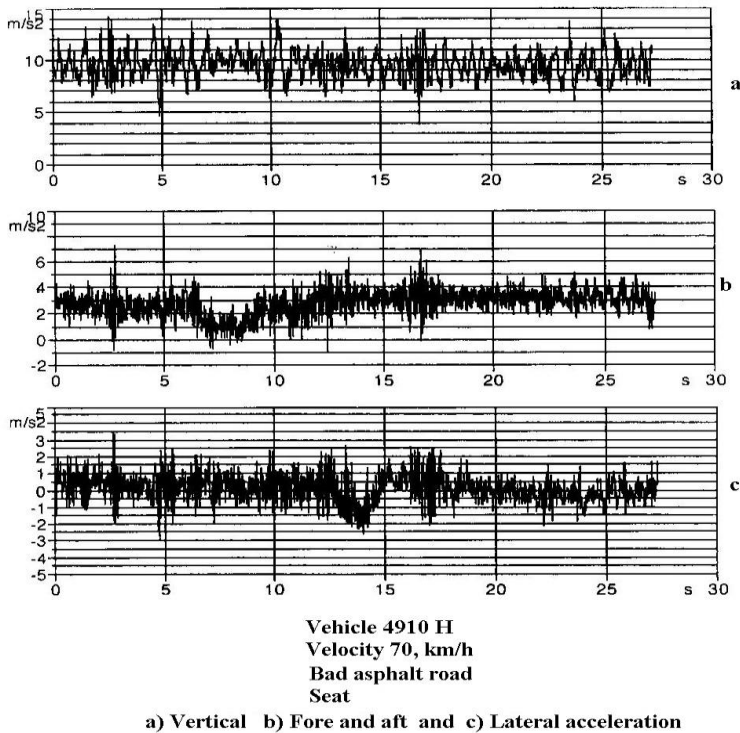

Figure 3 Seat vibration of vehicle 4910H driven on bad asphalt road, vehicle speed was 70 km/h: a-vertical, b-fore and aft and c-lateral direction

3. DATA ANALYSIS

Procedure of data analysis depending on testing vehicle will be given in this chapter. [11][12].

3.1 PASSENGER CARS

Experimental research included more different influencing factors which should be analysed in detail. Preliminary analysis showed that all recorded signals are random and statistically methods should be applied, [9].

Root mean square values of accelerations (R.M.S.) are significant value for ride comfort assessment, [7] except in case that crest factor is less 6, and higher than 9, according to ISO 2631/1 recommendation, [7]. The influence of some factors on human's vibratory loads are investigated by application of acceleration r.m.s. Measured r.m.s. accelerations are normalized and are weighted according to ISO 2631/1 [7].

Average value, r.m.s. value and standard deviation of acceleration signals are determined. Random error, caused by random signal of limited duration, is determined

according to, [3]: $\varepsilon_r = \frac{\sigma_x}{\mu_x \sqrt{n}}$, and is between $4.07 \cdot 10^{-4}$ and 0.0256 []. Random error

caused by determination of r.m.s. values, [3] is : $\varepsilon_r = \sqrt{\frac{2}{n}}$ and its value is 0.03125 []. Crest

factor for all measurement is between 1.04719-3.0769 [], which is satisfactory condition defined in [35].

Experimental results are analysed by analysis of variance method for factorial experiment. Four factors are analyzed (*road surface, vehicle speed, vehicle model and acceleration direction*), and are given in Table 1.

Table 1 Experimental factors

Factor	Number of factor level	Factor level
A – road	a=2	1 - good asphalt 2 - bad asphalt
B – speed	b=3	1 - 30 km/h 2 - 60 km/h 3 - 90 km/h
C – vehicle model	c=4	1 - Fiat Croma 2 - Florida, serial suspension system 3- Florida, prototype of suspension system 4 - Yugo 65 cl
D – acceleration direction	d=3	1 – X 2 – Y 3 – Z

Analysis of variance enabled the influence of external factors and measurement errors on experimental results in case when it is possible to combine one level of one factor with all levels of other factors [9].

Analysis of variance method is described in detail in [9]. Necessary expressions for analysis of three factors experiment are given in [9]. For four factors experiments, expressions are developed based on three factors experiment.

Degrees of freedom of factors are given in table 2, according to [9].

Table 2 Variance table of RMS accelerations

Excitatione	Degree of freedom	Sums of squares	Average square	v_0	C for V=95%
A	1	1.09424	1.094238	0.02979	254

B	2	6.318848	3.159424	0.08601	19.5
C	3	30.72168	10.24056	0.27879	8.53
D	2	5231.779	2615.889	71.2154	19.5
AB	2	1.602832	0.801416	0.02182	19.5
AC	3	5.728472	1.909491	0.05198	8.53
AD	2	2.563704	1.281852	0.03489	19.5
BC	6	10.40352	1.733999	0.04720	3.67
BD	4	5.470605	1.367765	0.03723	5.63
CD	6	8.91543	1.485905	0.04045	3.67
ABC	6	52147.73	8691.288	185.204	3.67
ABD	4	416.2613	104.0653	74.2886	5.63
ACD	6	23294.97	3882.495	54.2886	3.67
BCD	12	8993.058	749.4214	5.30219	2.30
ABCD	12	94947.54	7912.295	112.587	2.30
Error	288	10578.83	36.7328		
Sum	359				

According to results of dispersion analysis given in Table 2 the factor D (direction factor) effect is significant. In addition, the factorial effect of fore and aft factor interaction is significant.

In order to decrease inter factor interaction transformation of coordinates are conducted, [9]. Coordinates transformation by using of square root, logarithm or square values caused stronger inter factor interactions [15,16,47].

International standard ISO 2631/1 [7], as well older standard issues, recommended frequency weighting of rms accelerations. Experimental results are weighted according to [7,19] in order to obtain reliable data.

Spectral analysis of acceleration time series were performed. Acceleration power spectrums are weighted by multiplying with weighting factors W_k (vertical direction) and W_d (fore and aft and lateral directions) for sitting position according to ISO 2631/1 [7]. Based on obtained weighted power spectrums r.m.s. values of accelerations are determined. Analysis of variance procedure is repeated. Results are given in detail in [11,12] and are the same as well as obtained previously.

Normalized R.M.S. values of acceleration signals are analysed by variance method analysis, the same procedure applied in previous section. Results are given in Table 3. Conclusions are the same as well as in previous two cases.

Table 3. Variance table of normalized RMS accelerations

Excitation	Number of factor level	Sums of squares	Average square	v_0	C for V=95%
A	1	13.26153	13.26153	42.311024	254
B	2	3.796913	1.898457	6.057043	19.5
C	3	0.835625	0.278542	0.888689	8.53
D	2	16.99749	8.498748	27.115332	19.5
AB	2	0.287930	0.143965	0.459322	19.5
AC	3	1.010636	0.336879	1.074815	8.53
AD	2	0.533410	0.266705	0.850925	19.5
BC	6	1.404979	0.2341632	0.747100	3.67
BD	4	0.5207565	0.1301891	0.415370	5.63
CD	6	0.2034459	0.033908	0.108183	3.67
ABC	6	453.7496	75.62494	241.283043	3.67
ABD	4	65.9325	16.48313	52.589558	5.63
ACD	6	221.6583	36.94305	117.867134	3.67
BCD	12	148.273	12.35608	39.422184	2.30
ABCD	12	967.4673	80.62228	257.226074	2.30
Error	288	90.26733	0.313429	0.313430	
Sum	359				

Results can be analysed by application of regression test of significance. Method was described in detail in [64]. Elements given in Table 4 are determined according to [9]. Confirmation of factorial experiment by method of regression test of significance was given in Table 4.

Conclusions obtained by application of analysis of variance and regression test of significance are the same. Influential factor on acceleration level is direction factor *D*.

Regression test of significance method has advantage over analysis of variance method in easier calculation especially in factorial experiment with high level and number of factors. Application of previously method could not obtain analysis of inter factor relationships [9].

Further analysis is subordinate to type of factors. Analysis of variance is the same in both cases. Factor of direction has the most significance level and is confirmed by average values analysis.

In order to compare average values, in reference to determine direction of dominant loadings of passenger, Student's t-test is determined according to [9]:

$$t_0 = \frac{D}{s \sqrt{\frac{1}{r} \left(\frac{1}{m} + \frac{1}{n} \right)}}, \quad (1)$$

where are: s - standard error dispersion, r - number of repeated readings for the same factor combination, n and m - numbers of average values in comparing groups. Value D is:

$$D = \frac{\bar{x}_1 + \dots + \bar{x}_n}{n} - \frac{\bar{y}_1 + \dots + \bar{y}_m}{m}, \quad (2)$$

where are x_i and y_i are two compared groups of average values. Criterion has the same degree of freedom as well experiment error. Value v_0 is standard value and based on criterion $v_0 > v_{0table}$ group of higher average values can be determined, [9].

Number of repeated readings in experiment was $r=5$ and number of compared average values are $m=n=24$. According to table 2 value s is:

$$s = \sqrt{\text{Average square error}} = 6.06069.$$

For degree of freedom value 288 and confidence interval $\alpha=0.05$ i $t_{0table}=1.96$, determined values of t_0 can be compared:

$$\begin{aligned} t_0[x, y] &= 8.228392 & \ddot{X} > \ddot{Y}, \\ t_0[z, x] &= 233.0132 & \ddot{Z} > \ddot{X}, \\ t_0[z, y] &= 241.2416 & \ddot{Z} > \ddot{Y}. \end{aligned} \quad (3)$$

According to equation (3), the highest loading of human in operational conditions are in vertical direction and the lowest is in the lateral direction.

Conducted experiment is analyzed as factorial experiment, because all factor combinations could be arranged [64].

Analysis of variance and regression test of significance pointed out significant direction factor. Analysis showed that transformation of coordinates should not be performed, as well as acceleration weighting in order to determine the most influenced factor, [11,12,21], results are the same. Analysis of average values showed that dominant loadings are i vertical direction and the lowest is in lateral direction.

Table 4. Regression test of significance

Factor	m	t _j	SR(m,t _j)	SR(m')	SF	SG	v ₀	V _{0table}
A	3.9669083	0.0550678 -0.055066	5666.1834	5665.0227	1.160664	5786.8166	0.0718	254
B		-0.164235 0.1601642 4.07087e-3	5671.4072		6.384521	5781.5928	0.1971	19.5
C		-0.0151805 -0.2493305 -0.2169972 0.4815106	5695.8098		30.787086	5757.1902	0.6345	8.53
D		-2.5603766 -2.8286344 5.3890084	10896.835		5231.8118	556.165	1678.87	19.5

Assessment of linear dependence between two signals can be determined by correlation coefficient, according to [1]:

$$\rho_{xy} = \frac{\sigma_{xy}}{\sigma_x \sigma_y}, \quad -1 \leq \rho_{xy} \leq 1 \quad 4)$$

where are σ_x standard deviation of input signal, σ_y standard deviation of output signal, σ_{xy} covariance of signals x and y .

Correlation coefficients are determined according to (4) and are given in Table 5, are different from extreme values. There is both correlation between acceleration in vertical and longitudinal direction and correlation between vertical and lateral accelerations. There is nonlinear correlation between acceleration signals. Results are given in Table 5 in columns 7-9. Obtained results point out smaller correlation between signals. Comparison of correlation coefficients showed stronger relationship between vertical and longitudinal acceleration.

Coherence function that describes statistical couplings between two signals is analog to correlation coefficient. It is more convenient tool than correlation coefficient with respect to analysis of system behavior in frequency significant domain, [1].

Values of coherence function are in interval 0-1. Based on data given in figure 4 there is stronger statistically couplings between fore and aft acceleration and vertical acceleration than between lateral and vertical acceleration. It is obvious that there is nonlinear correlation between signals, [3].

Table 5 Correlation coefficients

σ_x	σ_y	σ_z	σ_{xy}	σ_{xz}	σ_{yz}	ρ_{xy}	ρ_{xz}	ρ_{yz}
0.021909	0.030954	0.080475	0.000321	-0.008141	0.006439	0.012342	-0.16314	0.15335
0.048247	0.092622	0.207435	0.007143	0.027635	0.02695	0.106859	0.276239	0.01945
0.048247	0.092622	0.207435	0.007143	0.027635	0.02695	0.106859	0.276239	0.01945
0.450209	1.008203	1.732715	-0.022318	0.291851	-0.028132	-0.033127	0.330439	-0.0218
0.128818	0.561031	0.493499	-0.009030	0.117296	0.021552	-0.033590	0.465214	0.04096
0.101608	0.24910	0.376176	0.027115	-0.008824	0.018481	0.170435	0.094527	-0.0288
0.030665	0.025234	0.106521	0.000417	0.021689	0.012679	0.014986	0.379494	0.24454
0.057712	0.057528	0.096853	-0.010524	0.032849	0.008958	-0.18264	0.439378	0.12009
0.085830	0.075939	0.315493	0.013744	0.074922	0.026792	0.170244	0.455296	0.17309
0.743727	0.802565	0.335762	-0.118843	0.851143	0.142046	-0.153824	0.538617	0.08653
0.562435	0.311502	0.133511	-0.0011183	0.308725	0.133236	-0.026717	0.356215	0.20657
0.384022	0.257761	0.621458	-0.027205	0.181111	-0.043076	-0.08647	0.370733	-0.1076
0.405643	0.265238	0.371269	0.005157	0.159862	0.000657	0.015721	0.411935	0.00209
1.002021	0.824650	1.399682	-0.086248	0.612796	-0.0990	-0.094031	0.512810	-0.0921
0.892577	0.775624	1.788532	-0.097902	0.732115	-0.022050	-0.117664	0.579439	-0.0187
0.076736	0.109851	0.131883	-0.064051	0.016619	-0.00711	-0.697623	0.165200	-0.0059
0.062012	0.068803	0.187060	-0.024304	0.013344	0.007064	-0.372084	0.117666	0.06558
0.025505	0.022215	0.092893	0.000579	-0.002728	0.011264	0.024340	0.247947	-0.0560
0.123422	0.340681	0.278213	-0.054883	0.055898	-0.008012	-0.267648	0.301654	-0.0260
0.054973	0.073076	0.165952	0.006817	0.025106	0.025157	0.0107563	0.262848	0.22848
0.123422	0.340681	0.278213	-0.054883	0.055898	-0.008014	-0.267648	0.301654	-0.0260
0.515318	0.348888	1.747677	-0.058049	0.475656	0.166879	-0.136904	0.501215	0.21371
0.269019	0.105881	0.457689	-0.046379	0.146154	0.034476	-0.274796	0.416518	0.15660
0.080283	0.103750	0.211660	-0.030203	0.012092	0.00137	-0.330932	0.092759	0.00922

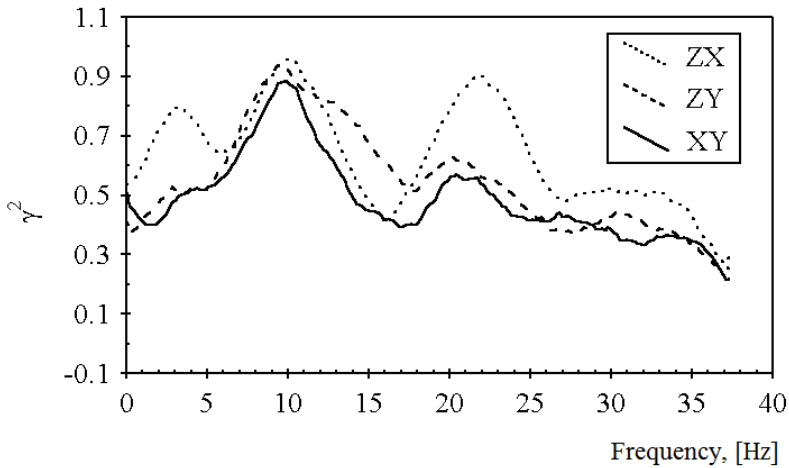

Figure 4 Coherence function between accelerations in for and aft and lateral directions and vertical directions

Loadings affected on human are analysed by Seat to head transfer function in three directions, figures 4, 5 and 6.

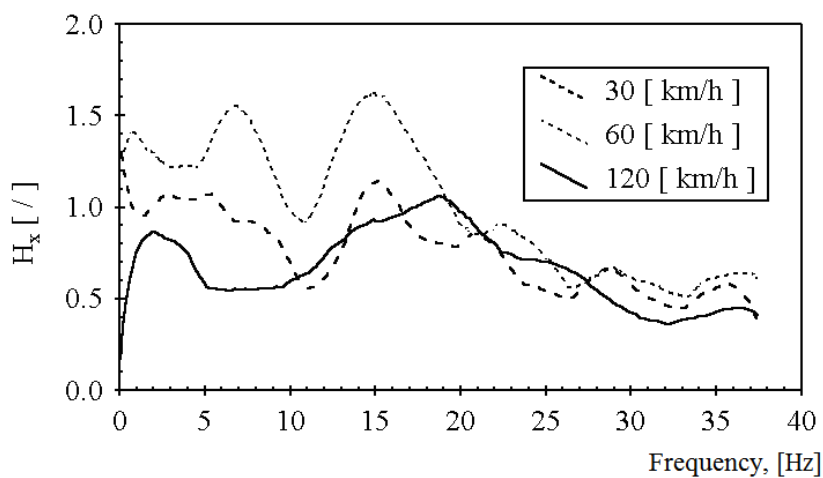

Figure 5 The influence of vehicle speed on transfer function of floor seat in fore and aft direction

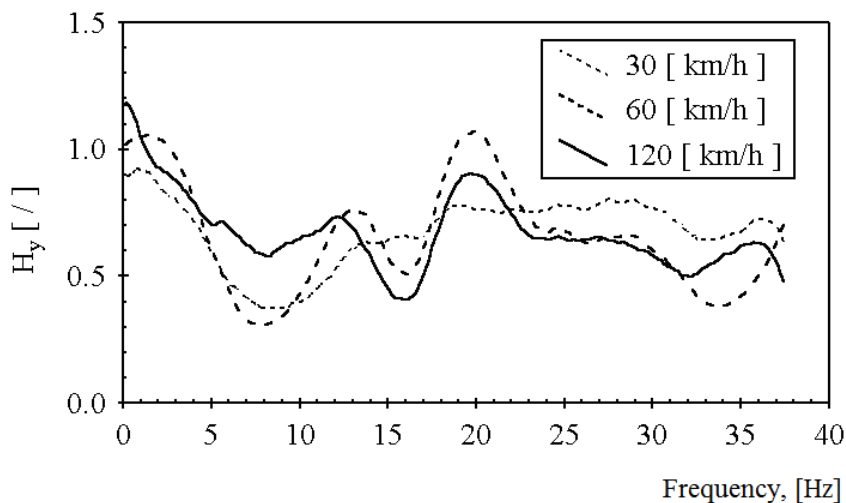

Figure 6 The influence of vehicle speed on transfer function of floor seat system in lateral direction

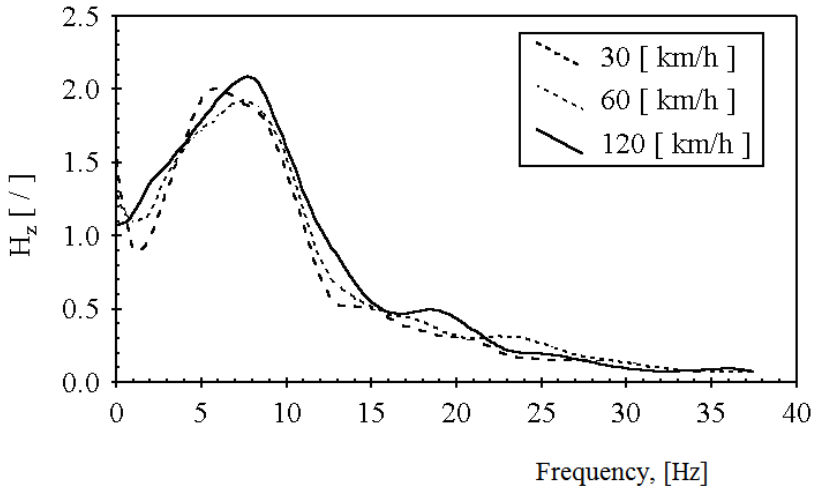

Figure 7 The influence of vehicle speed on transfer function of floor seat in vertical direction

Change of vehicle speed affected change of transfer function amplitude that indicated that system floor - seat is nonlinear in all directions [11].

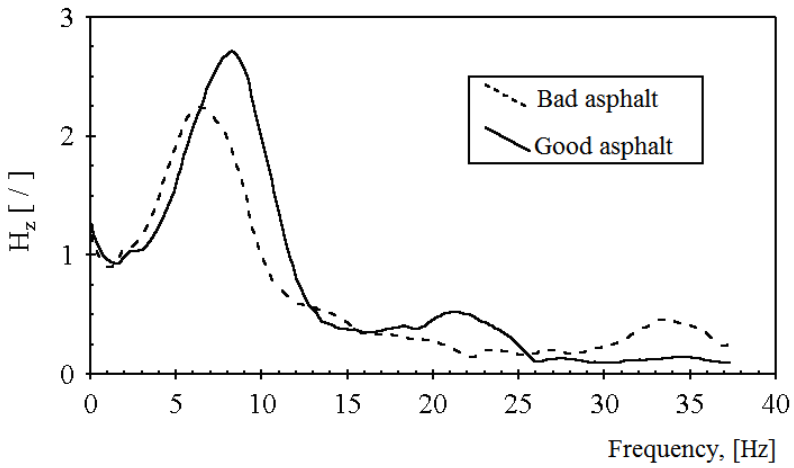

Figure 8 The influence of road surface on transfer function of floor seat system in vertical direction

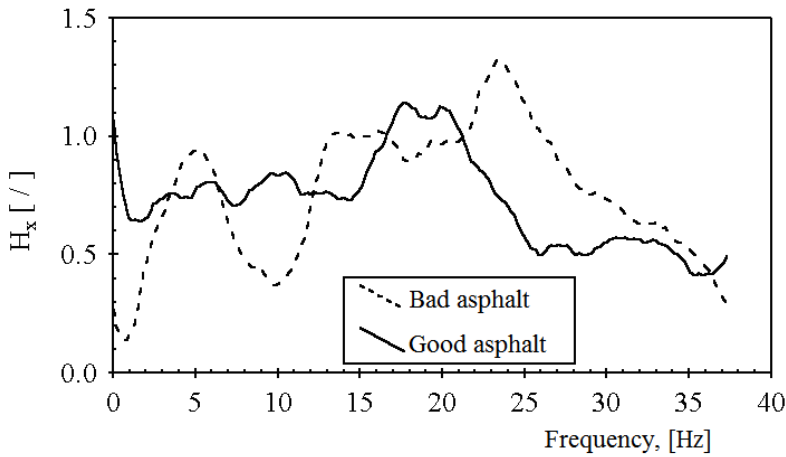

Figure 9 The influence of road surface on transfer function of floor seat system in fore and aft direction

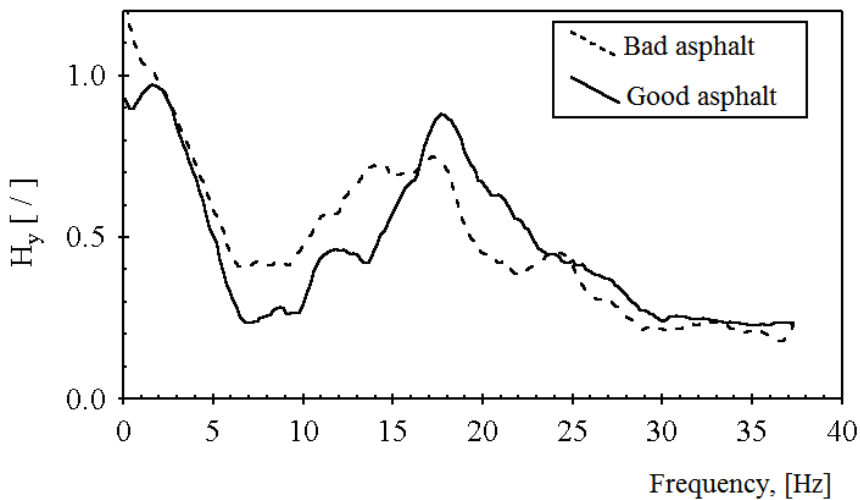

Figure 10 The influence of road surface on transfer function of floor seat system in lateral direction

The influence of road surfaces on transfer function of floor seat system is given in figures 8 - 10 (good and bad asphalt) in all three directions. Presented diagrams pointed out on system nonlinearity.

In order to determine couplings between acceleration signals in vertical and lateral and fore and aft directions partial coherence function is determined. Field investigations were performed in order to define dominant loading directions and to define excitations direction for further research.

If system has two input $x_1(t)$ and $x_2(t)$ and one output (z) than partial coherence function $\gamma_{2y,1}$ represents statistical correlation between signals x_2 and y , when linear effects of input signal x_1 are removed from both signals. Partial coherence function is:

$$\gamma_{2y,1}^2 = \frac{|S_{2y,1}|^2}{S_{22,1}S_{yy,1}}, \tag{5}$$

where are:

- $S_{22,1}$ and $S_{yy,1}$ conditional autospectrums of x_2 and y signals when linear effects of x_1 signal are removed from x_2 and y signals and
- $S_{2y,1}$ conditional cross spectrum of x_2 and y signals when linear effect of x_1 signal are removed [1].

When input signals x_1 and x_2 , are acceleration signals in fore and aft direction x and lateral direction y , and output signal z is acceleration signal in vertical direction, partial coherence function between z and y signals, when the linear effects of signal x is removed is:

$$\gamma_{yz,x}^2 = \frac{|S_{yz,x}|^2}{S_{yy,x}S_{zz,x}}. \tag{6}$$

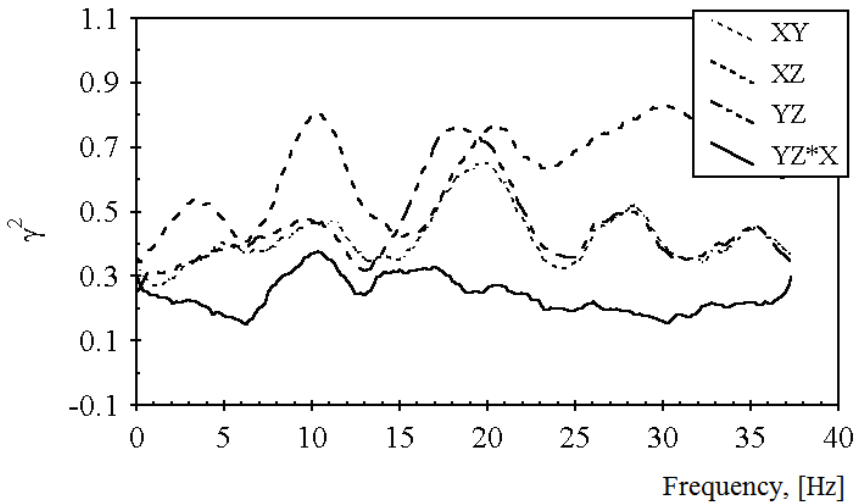

Figure 11 Ordinary coherence function and partial coherence function

According to diagram given in figure 11, there is stronger correlation between accelerations in fore and aft and vertical direction than accelerations in lateral and vertical direction. Diagrams given in figure 11 showed that low level of partial correlation between acceleration in vertical and lateral direction (maximum values are up to 0.4 when linear effect of signals in fore and aft directions are removed).

Performed analysis showed that dominant oscillatory loads of passengers are in vertical and fore and aft directions and observed system is non-linear in all three directions.

Results obtained in field experiments are starting point for further laboratory investigations of passenger cars ride comfort. The broadband random excitations affect on human body in sitting position and will be investigated in further laboratory experiments.

3. 2 HEAVY VEHICLES

According to average r.m.s. values of accelerations in extreme operational conditions and maximal values of acceleration magnitudes, crest factor is less than 9, which caused to apply assessment methods based on r.m.s. accelerations values, [7].

Root mean squares values of accelerations are determined from 1/3 octave spectrums with constant relative bandwidth. R.M.S. values of vertical and horizontal (fore and aft and lateral) accelerations are compared with equivalent comfort curve of 8 hours, according to standard ISO 2631/85, and r.m.s. values of accelerations in vertical and horizontal directions on steering wheel are compared with equivalent comfort curves for 4-8 hours according to standard ISO 5349/79. Equivalent comfort curves for 4-8 hours are adopted as well reference. Vibration measured on the steering wheel are not considered in this paper.

Spectrums of r.m.s. accelerations on the seat are given in figures 12 - 13. Accelerations are measured on seat of loaded truck 49 10H driven on bad asphalt road with speed 70 km/h.

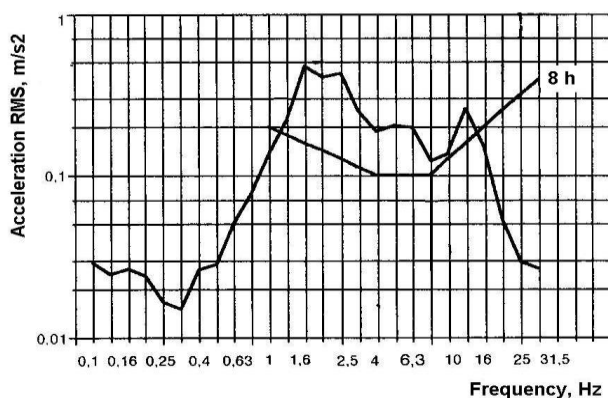

Figure 12 Spectrum of vertical accelerations measured on seat, respect to equivalent comfort curves for 8h, according to ISO 2631/85

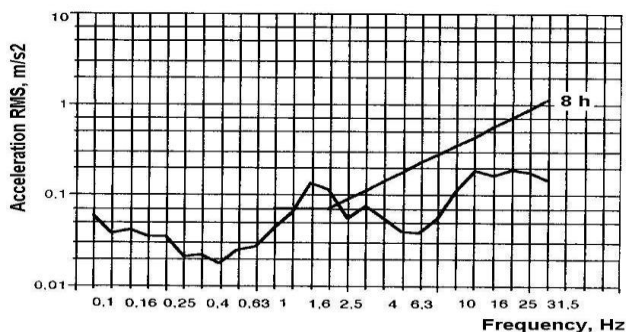

Figure 13 Spectrum of fore and aft accelerations measured on seat, respect to equivalent comfort curves for 8h, according to ISO 2631/85

Analysis of vertical accelerations spectrums showed significant spectrums density in frequency region between 2 and 8 Hz, where are human body resonances. Power spectrums are highest in vertical directions and the lowest in horizontal (lateral) directions. Spectrum

of vertical acceleration measured on the floor has more power than acceleration spectrums measured on the seat and steering wheel.

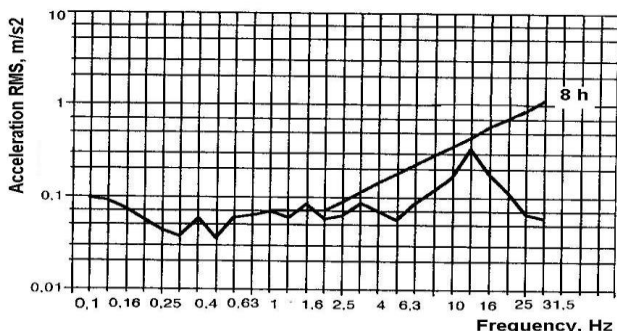

Figure 14 Spectrum of lateral accelerations measured on the seat respect to equivalent comfort curves for 8h, according to ISO 2631/85

Vehicles used in this investigation do not satisfy requirements of standard ISO 2631/8 for equal comfort curves for 8 hours in vertical direction and satisfy requirements for horizontal (fore and aft lateral) vibrations.

In order to determine dominant oscillatory loads of users of duty vehicle, analysis of variance method were applied, the same method applied on passenger cars.

Performed experiment has four influenced factors, described in table 6.

Table 6 Experimental factor

Factor	Factor level	Elements
A-road	a=2	1-good asphalt 2-bad asphalt
B-loading	b=2	1-loaded 2-unloaded
C-vehicle model	c=3	1-4910H 2-7912 3-110E18
D-direction	d=3	1-x 2-y 3-z

Results of performed analysis are given in table 7.

Table 7. Variance table of RMS accelerations

Excitation	Degree of freedom	Summs of squares	Average square	v_0	C for $v=95\%$
A	1	0.61	761	0.0554	3.90
B	1	0.84	0.84	0.006	3.90
C	2	0.30	5.15	0.037	3.06
D	2	2794	1397	10.18	3.06
AB	1	258	6258	45.61	3.90
AC	2	6220	3110	22.66	3.06
AD	2	6216	3108	22.66	3.06
BC	2	6218	3109	22.66	3.06

BD	2	6218	3109	22.66	3.06
CD	4	6226	1556	11.34	2.43
ABC	2	-12468	-6234	-45.4	3.06
ABD	2	-12486	-6243	-45.5	3.06
ACD	4	-15188	-3797	-27.66	2.43
BCD	4	-12456	-3114	-22.69	2.43
ABCD	4	-3460	-865	-6.30	2.43
Error	144	19757	1372		
Summ	179	2856			

Degree of freedom was 144 and confidence interval was $\alpha=0.05$ and $t_{0tablično}=2.62$ [12]. Obtained values of t_0 can be mutually compared. Results are:

$$t_0[z, x] = 18.86 > 2.62 \rightarrow \ddot{z} > \ddot{x},$$

$$t_0[z, y] = 20.14 > 2.62 \rightarrow \ddot{z} > \ddot{y}. \quad (7)$$

The highest loading is in vertical direction and the lowest loading is in lateral direction.

Performed experiment is analysed as factorial. The main condition for factorial experiment, possibility of mutual combination of all levels of all factors, was satisfied, [9].

Analysis of coherence functions between accelerations in three directions was performed.

Partial results of coherence function analysis are presented in figures 16 -19. Coherence functions between accelerations measured on the floor and seat of loaded duty vehicle Rival 4910.H driven on bad asphalt road are given.

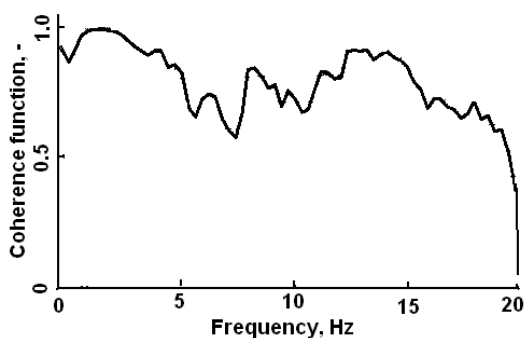

Figure 15 Coherence function between measured accelerations on the floor and seat, Z-direction

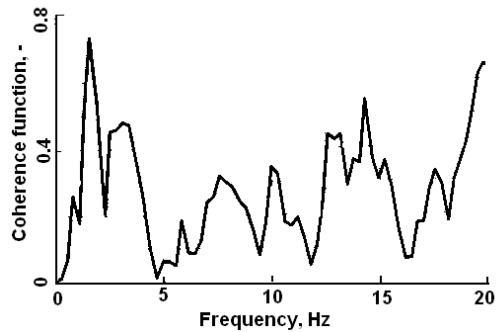

Figure 16 Coherence function between accelerations measured on the floor and seat, X-Y-direction

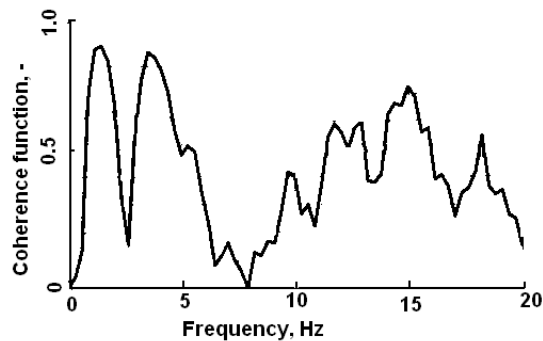

Figure 17 Coherence function between accelerations measured on the seat, Z-X-direction

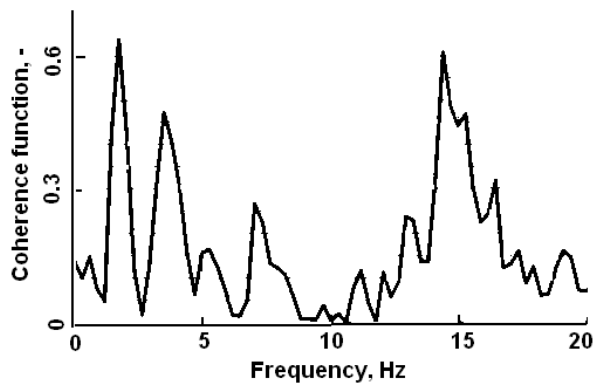

Figure 18 Coherence function between accelerations measured on the seat, Z-Y-direction

According to figures 16-19, there is higher level of linearity and mutual dependence between vertical and fore and aft accelerations than between vertical and lateral accelerations. The highest mutual dependence between vertical and fore and aft accelerations are in frequency region between 2 and 8 Hz and between 12 and 16 Hz.

Analysis of variance and coherence function analysis showed that dominant vibratory loads of trucks are in vertical and fore and aft directions.

4. CONCLUSIONS

Based on performed experimental investigation conclusions are:

- developed experimental methodology enables obtaining reliable results about factor effects on vibratory loads of human in motor vehicle (passenger car, truck),
- dominant vibratory loadings of human in passenger car are in vertical and fore and aft directions,
- dominant vibratory loadings of human in truck are in vertical and lateral directions,
- field experiment results obtained further laboratory investigations.

ACKNOWLEDGEMENT

Paper is result of project TR35041 financially supported by Ministry of education and science of Republic of Serbia.

References

- [1] Bendat J. S. and Piersol A.G.: Engineering Applications of Correlation and Spectral analysis, John Wiley & Sons, New York, 1980.
- [2] British Standard Institution: Measurement and evaluation of human exposure to whole body mechanical vibration and repeated shocks, BS 6841, London, 1989.
- [3] Corbridge C. and Griffin M. J.: Vibration and comfort: vertical and lateral motion in the range 0.5 - 5.0 Hz, Ergonomics, vol.29, No.2, 1986, pp. 249-272.
- [4] Giuliano F. and Bucco A.: A road test procedure for definition of the vibratory mission of automotive seats, 3rd International conference Vehicle comfort and ergonomics, Bologna, 1995
- [5] Griffin M. J., Whitham E. M. and Parsons K. C: Vibration and comfort I: Translational seat vibration, Ergonomics, vol. 25, No. 7, 1982, pp 603-630
- [6] Griffin M. J.: Handbook of Human Vibration, Academic Press, London, 1990.
- [7] International Standardization Organization: Guide for the evaluation of human exposure to whole body vibration, ISO 2631/1, Geneva, 1997.
- [8] Khatib A. E., Guillon F. and Domont A.: Vertical transmission through the lumbar spine of the seated subject-first results, Journal of Sound and Vibration, Vol. 215, No. 4, 1998.
- [9] Kostić M.: Statistical methods of analysis with computational approach, in Serbian, Naučna knjiga, Beograd, 1988.
- [10] Latherwood J. D., Dempsey T. K. and Clevenson S. A.: A Design Tool for Estimating Passenger Ride Discomfort Within Complex Ride Environments; Human Factors, vol.22, No.3, 1980, pp 291-312
- [11] Lukić J.: Ride comfort parameter identification of passenger cars, Ph.D. Thesis, University of Kragujevac, Faculty of Mechanical engineering, Kragujevac, 2001.
- [12] Milić Ž.: Ph.D. Ride comfort parameters of heavy vehicles, PhD Thesis, University of Kragujevac, Faculty of Mechanical engineering, Kragujevac, 2001.

- [13] Osborne D. J., Boarer P. and Heath T. O.: Variations in response to whole body vibration.. Intensity dependent effects, *Ergonomics*, vol. 24, No. 7, 1981, pp 523-530
- [14] Osborne D. J., Heath T. O. and Boarer P.: Vibration in human response to whole body vibration, *Ergonomics*, Vol. 24, No. 4, 1981, pp 301-313
- [15] Paddan G. S. and M. J. Griffin: The transmission of translational seat vibration to the head - I. Vertical seat vibration, *Journal of Biomechanics*, Vol. 21, No 3, 1998, pp 191-197.
- [16] Paddan G. S. and M. J. Griffin: The transmission of translational seat vibration to the head - II. Horizontal seat vibration, *Journal of Biomechanics*, Vol. 21, No 3, 1998, pp 199-206.
- [17] Wheeler A., Ganji A.: *Introduction to Engineering experimentation*, Prentice Hall, 2010.
- [18] Simić D.: *Beitrag zur Optimierung der Schwingungseigenschaften des Fahrzeuges Physiologische Grundlagen des Schwingungskomfort*, Doctor Disertation, TU Berlin 1970.
- [19] Simić D., Robbins D. R.: General human vibration: International standard ISO 2631, state and research trends, *MVM*, No. 58/59, Vol X, Kragujevac, 1984, pp. 452-473,
- [20] Simić D.: The influence of complex mechanical oscillations on human, *MVM*, 37/38, Vol VII, Kragujevac, 1981, pp.34-46.
- [21] Demić M., Lukić J., Milić Ž.: Some aspects of the investigation of random vibration influence on ride comfort, *Journal of sound and vibration*, Vol. 253, No 1, 2002, pp. 109-129