

Identification of coulomb, viscous and particle damping parameters from the response of SDOF harmonically forced linear oscillator

Mr.U.L.Anuse.

*Department of Mechanical Engineering, Solapur University/ WIT/Solapur/ India
uttamanuse@gmail.com*

Prof.S.B.Tuljapure

Department of Mechanical Engineering, Solapur University/ WIT/Solapur/India

Abstract

This paper deals with Theoretical and Experimental methods for identification of coulomb ,Viscous and Particle damping parameters from the response of Single degree of freedom harmonically forced linear oscillator when system damped with more than one type of damping ,which parameter is responsible for the control of resonant response of vibrating systems, in experimental method setup have been presented to investigate steady state response amplitude x_i for SDOF system for different values of amplitude Y_i of the base excitation from this relationship of (X_i, Y_i) the values of viscous damping coefficient 'c' and coulomb friction force F_0 ,also equivalent viscous damping ratios ,have been calculated from frequency response analysis for the systems with viscous damping ,Viscous and Coulomb friction damping, coulomb friction damping and particle damping by using half power band-width method and in theoretical studies expression for steady state amplitude X_0 obtained is used to study the effect of frequency ratio and coulomb friction parameters on phase angle and amplitude ratio.

Keywords: Coulomb Friction parameter; Damping ratio; Half power band method; Damping Coefficient; Resonant frequency; Excitation frequency; Particle damping; Viscous damping ; Coulomb damping

Relevance

In many situations, it is important to identify damping information from a vibration system with both Coulomb and Viscous sources of damping. Their frequent occurrence in practical engineering has aroused for a long time the interest of many researchers in the vibration field. Friction dampers (with viscous damping as the system damping) are used in gas turbine engines, high speed turbo pumps, large flexible space structures under carriage of railway bogie, vehicle suspension systems etc. These dampers are used to reduce resonant stresses by providing sliding contact between points experiencing relative motion due to vibration, thereby dissipating resonant vibration energy.

Introduction

Methods of vibration control

The problem of reducing the level of vibration in dynamic systems arises mainly due to increase in operating speeds of the machines, large dimensions of constructions, stricter standards and norms by the environmental pollution boards and technological demands placed on keeping vibrations down to accepted levels. The important ways and means of controlling unacceptable vibrations in machines are:

System Modification: Changing the rigidity (stiffness) and or inertial parameters (mass, inertia) to modify natural frequency or frequencies of the dynamic systems.

Vibration Isolation: Use of isolation techniques in which either the source of vibration is isolated from the system concerned (force transmissibility case) or a device is protected from its point of attachment (motion transmissibility case). The isolation systems can be passive, semi-active or active.

Dynamic Vibration Absorber: A Dynamic Vibration Absorber is simplest device used to reduce the steady state vibrations of a system at a certain fixed frequency of excitation. It is a passive control device which is attached to a vibrating body subjected to force or motion excitation.

Method of Damping: Damping used is viscous damping viscoelastic damping, electro-rheological damping, magneto-rheological damping, eddy current damping, piezoelectric damping, or Particle damping etc. Passive, semi-active and active damping techniques are common methods of attenuating the resonant amplitudes excited of a structure/machine. Active damping amplitudes of a structure/machine. Active damping techniques are not applicable under all circumstances due to power requirements, cost, environment, etc. Under such circumstances, passive techniques are available alternative.

VISCOUS AND COULOMB DAMPING

Various forms of passive damping exist, including viscous damping, viscoelastic damping, friction damping, and impact damping etc. Viscous and viscoelastic damping usually have a relatively strong dependence on temperature. Friction dampers, while applicable over wide temperature ranges, may degrade with wear.

Den Hartog [5] has presented an exact solution for the steady-state vibration of a harmonically excited oscillator damped by combined dry and viscous friction. The system, as shown in figure (1.1), consists of a forced excited mass with friction forces acting between it and the ground. The several experimental tests to verify solutions have been performed to find out the forced response of a single-degree-of-freedom system with both viscous and dry friction damping.

Hundal [6] studied a base-excitation frictional oscillator as shown in figure (1.2), in which close form analytical solutions of the equation of motion were obtained. Results have been presented in non dimensional form as magnification factors versus frequency ratios as functions of Viscous and Coulomb friction parameters. It has been shown that the mass motion may be continuous or one stop during each cycle, depending upon system parameters. The response of a single degree of freedom spring-mass system with Viscous and Coulomb friction, with harmonic base excitation, has been determined.

Levitan [7] analyzed the motion of a system with harmonic displacement of the base, as shown in figure (1.3). The friction forces in his model act between the base and the mass. An analytical solution for the response of the support-excited system has been presented. The solution to the equation of motion has been developed through the application of a Fourier series to represent the frictional force opposing the relative motion between mass and supporting structure.

Perls and Sherrard [8] have extended the results of Den Hartog through the ranges applicable to inertial instruments as accelerometers and jerk meters. They obtained the curves with analog computers for the magnification factor verses frequency ratio of second order systems with combined Coulomb and Viscous damping. The figure (1.4) shows a typical vibration instrument with its frame rigidly attached to a sinusoidal vibrating structure having a motion $X \cos \omega t$.

Ferri and Dowell [9] have investigated the vibration response of both single and multi degree-of-freedom systems with combined dry friction and viscous damping.

Jacobsen and Ayre [10] have developed an approximate scheme for estimating both viscous and dry friction quantities from the free-vibration decrements by noting that the viscous friction dominates in the large-amplitude responses, and that Coulomb friction dominates in the small-amplitude oscillations. As such, they exploited the exponential and linear decay of a free vibration Viscous or Coulomb-friction damped system.

Dimentberg [15] to generate identification equations. A non-linearly damped Single-Degree-Of-Freedom (S.D.O.F. for the short) system under broadband random excitation is considered. A procedure for in-service identification of the damping characteristic from measured stationary response is described damping

mechanisms from measured random vibration data. Extensive results of numerical tests for the procedure have been presented.

Marui and Kato [16] have worked out a brief analytical technique for the behavior of the linear forced vibratory system under the influence of a Coulomb friction force, as shown in figure (1.5). The analysis has been based on the new simple idea of stopping region. Using this technique, the behavior of the system in the low exciting frequency range, where the remarkable influence of friction easily develops, has been examined and the results have been compared with the experimental ones.

Liang and Feeny [19] have proposed a simple identification algorithm for estimating both Viscous and Dry friction in harmonically forced single degree of freedom mechanical vibration systems. The method has been especially suitable for the identification of systems for which the traditional free-vibration scheme is difficult to implement. Numerical simulations have been included to show the effectiveness of the proposed algorithm. A numerical perturbation study has been also included for insight on the robustness of the algorithm.

Liang and Feeny [1] have presented a method for estimating Coulomb and Viscous friction coefficients from responses of a harmonically excited dual-damped oscillator with linear stiffness. The identification method has been based on existing analytical solutions of non-sticking responses excited near resonance. Schematic diagram depicting a SDOF oscillator with viscous, Coulomb friction and base excitation has been shown in figure (1.6).

Cheng and Zu [20] have studied a mass-spring oscillator damped with both Coulomb and Viscous friction and subjected to two harmonic excitations with different frequencies. By employing an analytical approach, closed form solutions for steady state response have been derived for both non-stop and one-stop motion. From numerical simulations, it has been found that near the resonance, the dynamic response due to the two-frequency excitation demonstrates characteristics significantly different from those due to a single frequency excitation. In addition, the one-stop motion has been demonstrated peculiar characteristics, different from those in the non-stop motion.

Theoretical and Experimental Methods for Identification of Coulomb, Viscous and Particle Damping Parameters from the Responses of a SDOF Harmonically Forced Linear Oscillator” have been carried out.

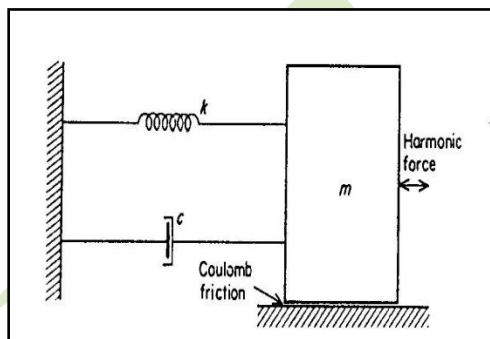

Fig.1.1 Schematic representation of the system, analyzed by Den Hartog [5]

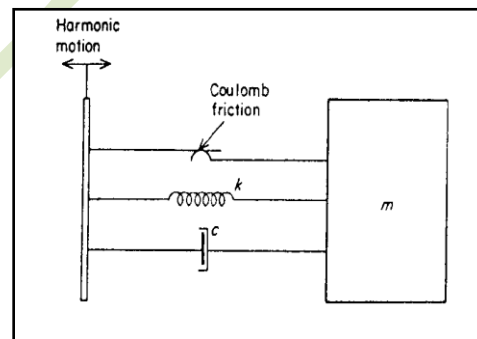

Fig.1.2 Schematic representation of the system, analyzed by Levitan [7]

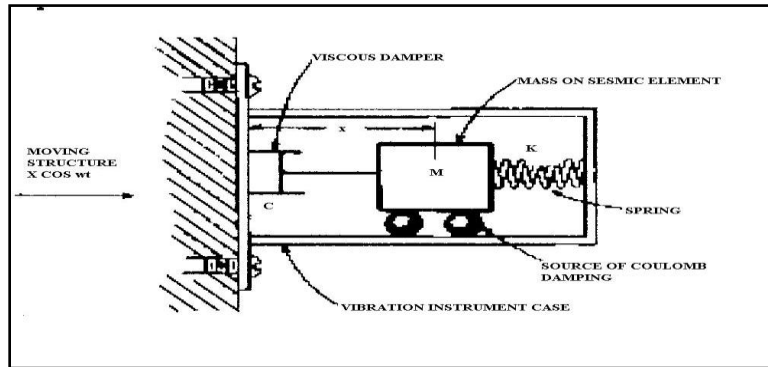

Fig.1.3 System with Coulomb friction between mass and ground, with harmonic excitation of the base analyzed by Hundal [6]

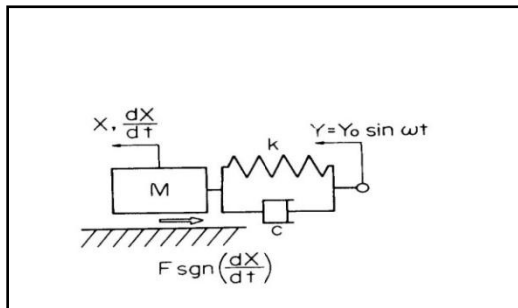

Fig.1.5 Forced vibratory system with Coulomb friction [16]

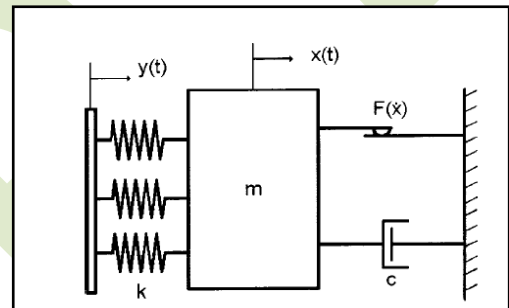

Fig.1.6 Schematic diagram depicting a SDOF oscillator with viscous, Coulomb friction and base excitation [1]

STEADY STATE RESPONSE ANALYSIS

Figure (2.1) shows a mass-spring-damper system, (SDOF) where a mass m is suspended from a spring with stiffness k and a viscous fluid damper with damping coefficient c and Coulomb friction force F . The mass is subjected to two harmonic excitations $P_1 \cos(\omega_1 t + \phi_1)$ and $P_2 \cos(\omega_2 t + \phi_2)$ with different frequencies.

$$\omega_1 = \frac{M}{N} \omega_2 \quad (2.1)$$

where M and N are integers and they have no common factors. Thus, the two external harmonic excitations can be regarded as a single nonharmonic, but periodic excitation whose frequency ω is calculated as the greater common divisor of the two original harmonic frequencies [20]

$$\omega = \frac{\omega_2}{N} \quad (2.2)$$

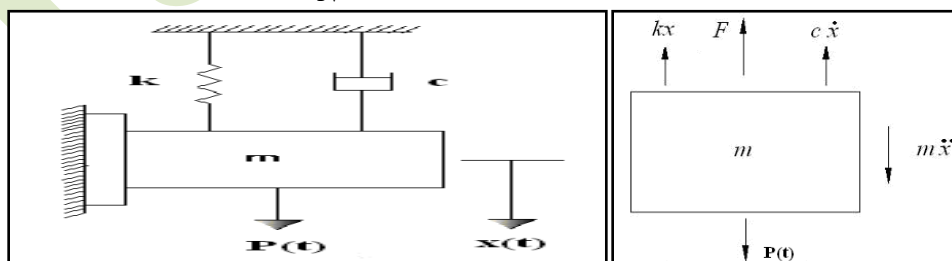

Fig. 2.1 A mass spring damper system subjected to excitation $P(t)$ Where $P(t) = P_1 \cos(\omega_1 t + \phi_1) + P_2 \cos(\omega_2 t + \phi_2)$ Fig. 2.2 Free Body Diagram

Referring the free body diagram of figure 2.2, the equation of motion of mass m is given as,

$$m\ddot{x} = P_1 \cos(\omega_1 t + \phi_1) + P_2 \cos(\omega_2 t + \phi_1 + \Delta\phi) - c\dot{x} - kx - (-\mu N) \quad (2.3)$$

After writing $F = \mu N$ and rearranging, the equation 2.3 becomes,

$$m\ddot{x} + c\dot{x} + kx = F + P_1 \cos(\omega_1 t + \phi_1) + P_2 \cos(\omega_2 t + \phi_1 + \Delta\phi) \quad (2.4)$$

Where, x is the displacement, and $\Delta\phi$ is the phase difference between two harmonic excitations, i.e., $\Delta\phi = \phi_2 - \phi_1$. Assuming that the response always starts ($t=0$) at maximum value, the phase difference between the first harmonic excitation and the motion is uniquely determined by the unknown phase angle ϕ_1 .

Correspondingly, the time boundary conditions of equation (2.4) take on the following simple form:

$$\begin{aligned} t = 0; \quad x = x_0, \quad \dot{x} = 0 \\ t = \pi/\omega; \quad x = -x_0, \quad \dot{x} = 0 \end{aligned} \quad (2.5)$$

Where x_0 is the amplitude of the vibration. Introducing the following parameters

$$\omega_n^2 = \frac{k}{m}, \quad x_f = \frac{F}{k}, \quad a_1 = \frac{P_1}{k}, \quad a_2 = \frac{P_2}{k}, \quad \xi = \frac{c}{c_c}, \quad c_c = 2m\omega_n \quad \text{and} \quad (2.6)$$

Dividing both sides by m of Eq. (2.4) one obtains,

$$\ddot{x} + \frac{c}{m}\dot{x} + \frac{k}{m}x = \frac{F}{m} + \frac{P_1}{m}\cos(\omega_1 t + \phi_1) + \frac{P_2}{m}\cos(\omega_2 t + \phi_1 + \Delta\phi) \quad (2.7)$$

Divide and multiply by k on right side of Eq. (2.7) one get,

$$\ddot{x} + \frac{c}{m}\dot{x} + \omega_n^2 x = \frac{F}{k} + \frac{P_1}{k}\cos(\omega_1 t + \phi_1) + \frac{P_2}{k}\cos(\omega_2 t + \phi_1 + \Delta\phi) \quad (2.8)$$

Upon substituting parameters from Eq. (2.6) one can write,

$$\ddot{x} + \frac{c}{m}\dot{x} + \omega_n^2 x = \omega_n^2 x_f + a_1 \omega_n^2 \cos(\omega_1 t + \phi_1) + a_2 \omega_n^2 \cos(\omega_2 t + \phi_1 + \Delta\phi) \quad (2.9)$$

The equation of motion, Eq. (2.9), then can be rewritten as,

$$\ddot{x} + \frac{c}{m}\dot{x} + \omega_n^2 (x - x_f) = \omega_n^2 [a_1 \cos(\omega_1 t + \phi_1) + a_2 \cos(\omega_2 t + \phi_1 + \Delta\phi)] \quad (2.10)$$

$$\begin{aligned} x = x_f + e^{-c t/2m} (C_1 \cos pt + C_2 \sin pt) + a_1 \beta(s_1) \cos(\omega_1 t + \phi_1 - \theta_1) \\ + a_2 \beta(s_2) \cos(\omega_2 t + \phi_1 + \Delta\phi - \theta_2) \end{aligned} \quad (2.11)$$

$$\text{Where, } p = \sqrt{\left(\omega_n^2 - \frac{c^2}{4m^2}\right)}, \quad \theta_i = \tan^{-1} \frac{2\xi s_i}{1 - s_i^2} \quad (i = 1, 2)$$

and C_1 and C_2 are two integration constants. (2.12)

The two constants C_1 and C_2 , the unknown amplitude x_0 and the phase angle ϕ_1 will be determined by using the four conditions in Eq. 2.5, as described in the procedure outlined in Appendix I from Eq. I-16 onwards.

The final expressions for the amplitude x_0 and phase angle ϕ_1 of the steady-state vibration for nonstop motion are obtained as,

$$x_0 = \frac{-b^* + \sqrt{b^{*2} - 4a^*c^*}}{2a^*} \quad (2.13)$$

$$\text{Where, } \begin{cases} a^* = (aP - dA)^2 + (dB - aQ)^2, \\ b^* = 2(aP - dA)(bP - eA) + 2(dB - aQ)(eB - bQ), \\ c^* = (bP - eA)^2 + (eB - bQ)^2 - (AQ - BP)^2. \end{cases} \quad (2.14)$$

The phase angle ϕ_1 is determined as,
$$\cos \phi_1 = \frac{BR - CQ}{AQ - BP} \quad (2.15)$$

Experimental Analysis

- i) An experimental set up has been designed and developed to obtain input output amplitude relationship for SDOF Harmonically excited system with Viscous, Viscous and Coulomb friction, and Viscous, Coulomb friction and Particle damping.
- ii) For this purpose, design and development of viscous fluid damper, dry friction damper and particle damping system has been carried out.

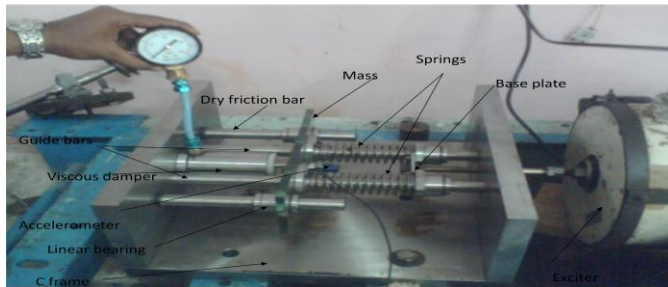

Fig 3.1 Experimental test set-up

Parameters	Spring stiffness $k_1/2=1511 \text{ N/m}$
Number of turns (N)	14
Wire diameter (d)	4mm
Mean diameter (D)	38 mm
Outer diameter (D ₀)	42 mm
Inner diameter (D _i)	34 mm
Spring index (C)	10

A schematic of the experimental test set-up is shown in the fig. (4.1) of the “C” frame. The frequency response curve of the system is obtained using the accelerometer pick up with its necessary attendant equipment and a FFT analyzer, over a small range of excitation frequency. The SDOF system taken for analysis has following parameters. mass $m = 1.0 \text{ kg}$, spring stiffness $k = 3022.0 \text{ N/m}$, coefficient of viscous damping $c = ?$, Coulomb friction force $F_0 = ?$ Using this experimental set-up, steady state response amplitudes x_i of the SDOF harmonically base excited system have been determined by exciting the system near resonance with excitation frequency near about 8.75 Hz. These values are given in Table 4.2.

Y_i	x_i		Y_i	x_i
$Y_1=0.701$	$x_1=4.05$		$Y_1=0.81$	$x_1=3.15$
$Y_2=0.7242$	$x_2=4.34$		$Y_2=0.986$	$x_2=5.34$
$Y_3=0.7514$	$x_3=4.68$		$Y_3=1.021$	$x_3=5.73$
$Y_4=0.7626$	$x_4=4.82$		$Y_4=1.114$	$x_4=64.84$
$Y_5=0.788$	$X_5=5.04$		$Y_5=5.04$	$X_5=8.31$

Table 4.2 the input/output amplitudes of experimental set-up

From this (Y_i, x_i) relationships, the values of viscous damping coefficient c and Coulomb friction force F_0 are determined as follows:

- i) A straight line relationship between Y_0 and x_0 has been obtained using regression analysis with points (Y_i, x_i) taken from Table 4.2.

- ii) The slope m and intercept z on the ordinate axis have been obtained as,

$$m = 0.08585 \text{ and } 0.083361, \quad z = 0.3517 \text{ and } 0.544535 \text{ mm}$$

- iii) Using the identification scheme presented in section 3.3 of chapter 3, the values of viscous damping coefficient c and Coulomb friction force F_0 are determined as follows:

a) Determination of viscous damping coefficient c :

The viscous damping ratio ζ is given as

$$\therefore \xi = \frac{Y_2 - Y_1}{2(x_2 - x_1)} = \frac{1}{2} \times \text{slope of line} = \frac{1}{2} \times m \quad (\text{refer Eq. 3.13})$$

From the slope $m = 0.08585$ and 0.083361 we get,

$$\therefore \xi = \frac{1}{2} \times \left[\frac{0.08585 + 0.083361}{2} \right]$$

$$\therefore \xi = 0.04230275 \quad \text{But, } \xi = c/c_c \quad \therefore \xi = c / (2\sqrt{mk}) \quad \therefore 0.04230275 = \frac{c}{(2\sqrt{1.0 \times 3022})}$$

\therefore viscous coefficient $c = 4.65$ N-sec/m

b) Determination of Coulomb friction force F_0 :

From the intercept, $z = 0.3517$ and 0.544535 mm we get,

$$Gx_f = z = \left[\frac{0.3517 + 0.544535}{2} \right] \quad (\text{refer Eq. 3.8})$$

$$\therefore Gx_f = 0.4481175 \quad \text{But, } G = \frac{\sinh(\xi\pi)}{\cosh(\xi\pi) - 1} \quad (\text{refer Eq. 3.14})$$

By putting the value of $\xi = 0.04230275$ determined just above one can get,

$$G = \frac{\sinh(0.04230275 \times \pi)}{\cosh(0.04230275 \times \pi) - 1} \quad \therefore G = 15.07127759$$

By substituting the value of G one can determine the value of x_f as,

$$\therefore x_f = 0.029733212 \quad \text{But, } x_f = \frac{F_0}{k} \quad (\text{refer Eq. 3.3})$$

$$\therefore F_0 = k \times x_f = 3022 \times 0.029733212$$

\therefore Coulomb friction force $F_0 = 89.85376666$ N

Thus the unknown values of viscous damping coefficient c and Coulomb friction force F_0 have been identified. Using the experimental set-up, the frequency response analysis has been carried out for a harmonically base excited SDOF system with

Type of damping	f_r (Hz)	X_r (microns)	f_1	f_2	ξ
S	8.75	4647.5	8.314	9.243	0.053
S+C	8.75	4437.5	8.178	9.561	0.076
S+P(T:-No balls)	7.5	6815	7.289	7.9	0.04
S+P(T:-200 balls)	7.5	6325	7.308	8.2	0.059
S+P(T:-300 balls)	7.5	6095	7.102	8.037	0.0623
S+P(T:-fully filled withballs)	7.5	4395	6.92	8.08	0.0778
S+V	9	194.5	8.508	10.687	0.121
S+V+C	9	113.83	7.93	10.506	0.1431
S+V+C+P (25%full balls)	9	143.5	7.138	11.04	0.2167
S+V+C+P (50%full balls)	9	121	7.63	11.95	0.2333
S+V+C+P (full balls)	9	117	7.82	12.08	0.2366

Table 4.4 Damping ratio ξ of various damping combination

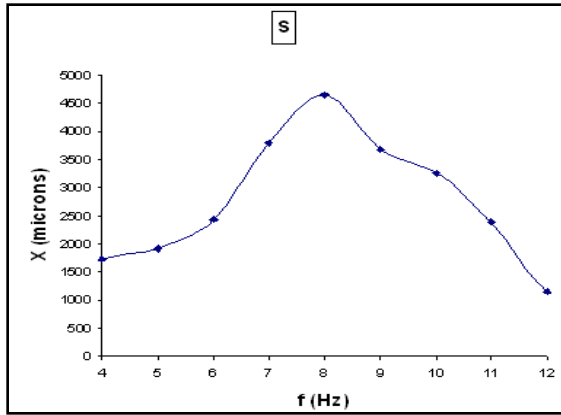

$f_n=8.75 \text{ Hz} ; f_1= 8.314 \text{ Hz} ; f_2= 9.243\text{Hz}$
 $\xi=0.053 ; X_r=4647.5 \mu\text{m}$

Fig. 1 Frequency response curve for ξ_s

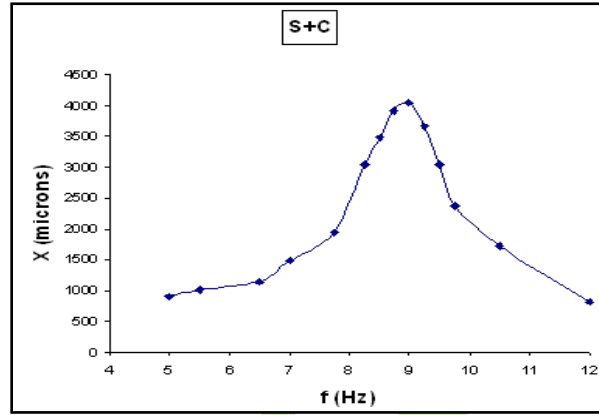

$f_n=8.75 \text{ Hz} ; f_1= 8.178 \text{ Hz} ; f_2= 9.561 \text{ Hz}$
 $\xi=0.076 ; X_r=4437.5 \mu\text{m}$

Fig.2 Frequency response curve for ξ_{s+c}

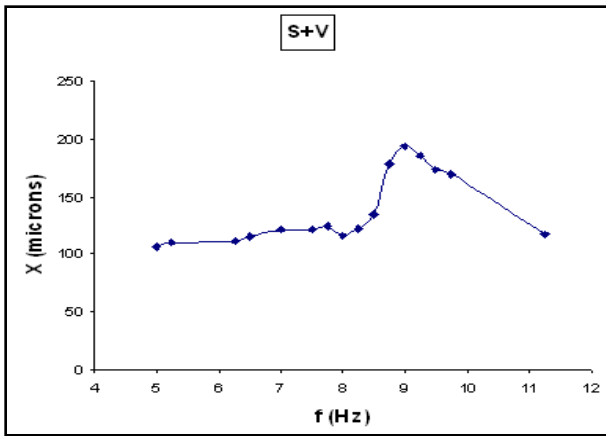

$f_n=9.0 \text{ Hz} ; f_1= 8.508 \text{ Hz} ; f_2= 10.68 \text{ Hz}$
 $\xi=0.121 ; X_r=194.5 \mu\text{m}$

Fig. 3. Frequency response curve for ξ_{s+v}

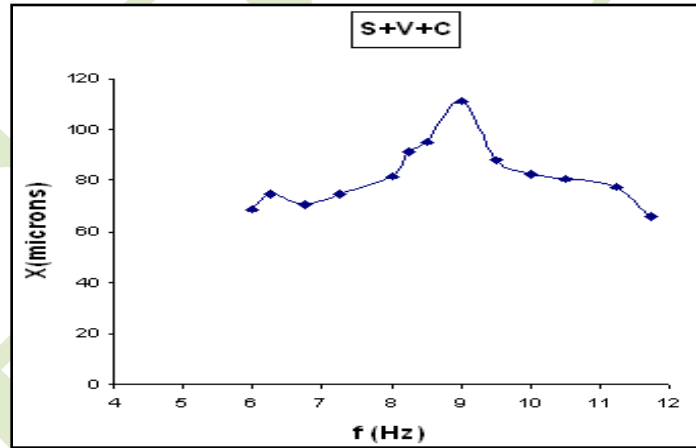

$f_n=9.0\text{Hz} ; f_1= 7.93 \text{ Hz} ; f_2= 10.5 \text{ Hz}$
 $\xi=0.143 ; X_r=113.83 \mu\text{m}$

Fig.4. Frequency response curve for ξ_{s+v+c}

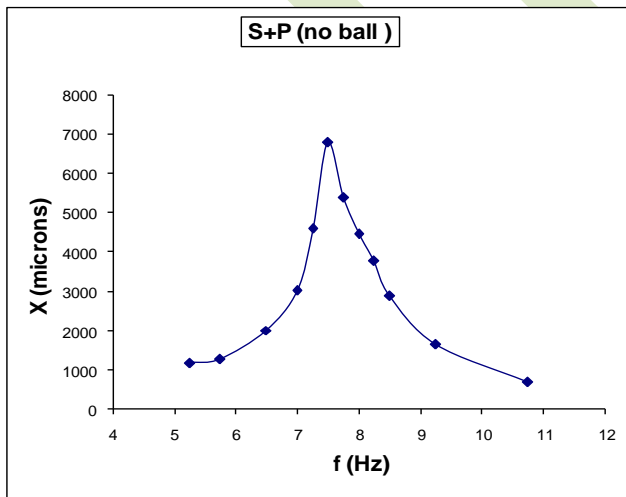

$f_n=7.5 \text{ Hz} ; f_1= 7.28 \text{ Hz} ; f_2= 7.9 \text{ Hz}$
 $\xi=0.04 ; X_r=6815 \mu\text{m}$

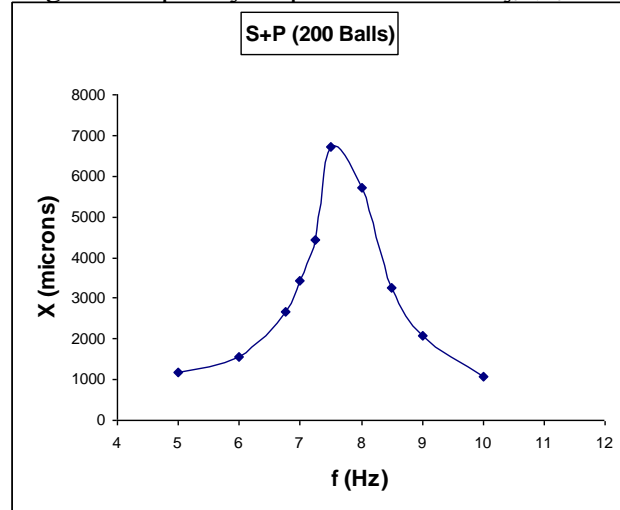

$f_n=7.5 \text{ Hz} ; f_1= 7.308 \text{ Hz} ; f_2= 8.2 \text{ Hz}$
 $\xi=0.059 ; X_r=6325 \mu\text{m}$

Fig.5. Frequency response curve for ξ_{s+p}

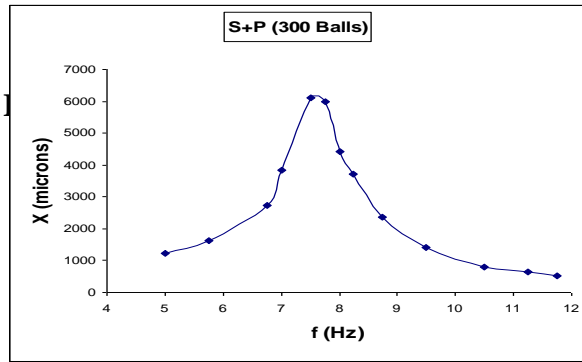

$f_n=7.5$ Hz ; $f_1= 7.102$ Hz ; $f_2= 8.63$ Hz
 $\xi=0.0623$; $X_r=6095$ μ m

Fig.7. Frequency response curve for ξ_{s+p}

Fig.6. Frequency response curve for ξ_{s+p}

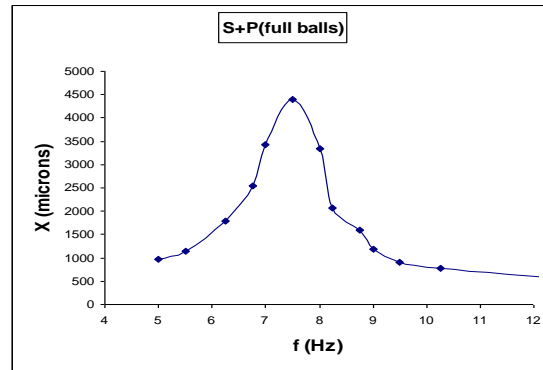

$f_n=7.5$ Hz ; $f_1= 6.92$ Hz ; $f_2= 8.08$ Hz
 $\xi=0.0778$; $X_r=4395$ μ m

Fig.8. Frequency response curve for ξ_{s+p}

RESULT AND DISCUSSION

1. Coulomb friction parameter F/P_1 has pronounced effect on resonant amplitude F/P_1 increases steady state amplitude x_0 decreases at a faster rate.
2. However, it was not cleared how much contribution of viscous friction in system & in many situations it is required to know content of viscous & Coulomb friction in the system.
3. So procedures is presented for identification of Coulomb & Viscous friction damping in a harmonically base excited SDOF vibrating system
4. Using experimental set up, steady state response amplitudes X_i of SDOF system have been determined by exciting system near resonance about 8.75 Hz. From these (Y_i, X_i) relationships, values of Viscous damping coefficient $c=4.65$ N-sec/m & Coulomb friction force $F_0 =1.062$ N were determined.
5. Frequency response analysis has been carried out for various types of damping combination. The amount of content of damping coefficient has been determined by using Half Power Band Width method.
 - a) ξ_{s+v} increases over ξ_s is of the order 1.28 times
 - b) ξ_{s+c} increases over ξ_s is of the order 0.433 times
 - c) ξ_{s+v+c} increases over ξ_s is of the order 1.7 times
 - d) $\xi_{s+v+c+p}$ increases over ξ_s is of the order 3.46 times

CONCLUSIONS

1. From the steady state response analysis carried out for a SDOF with Coulomb and viscous damping and subjected to harmonic excitations (two frequency and single frequency excitation), it is seen that the Coulomb friction parameter F/P_1 has pronounced effect on the resonant amplitude and as the value of Coulomb friction parameter increases, the steady state amplitude x_0 decreases at a faster rate.
2. Since the vibrating system has both viscous and Coulomb friction damping, Coulomb friction has pronounced effect on the resonant amplitude. It is not clear from the analysis how much is the contribution of the viscous friction in the system towards the reduction of resonant amplitude. In many situations, such as control system, it is necessary to know the content of the viscous and Coulomb friction damping in a given vibrating system. For that purpose, the identification of these two types of friction in a vibrating system will play a significant role when the control of vibration is carried out using the method of damping.

REFERENCES

- 1) J.W. Liang, and B.F. Feeny, 2004, "Identifying Coulomb and Viscous Friction in Forced Dual-Damped Oscillators," ASME J. Vib. Acoust., 126, pp. 118–125.
- 2) Steven E. Olson, 2003, "An analytical particle damping model" J. Sound Vib. 264, pp.1155–1166.
- 3) M.R. Duncan, C.R. Wassgren and C.M. Krousgrill 2005, "The damping performance of a single particle impact damper", J. Sound Vib. 286, pp.123–144.
- 4) Mao, K. M., Wang, M. Y., Xu, Z. W., and Chen, T. N., 2004, "Simulation and Characterization of Particle Damping in Transient Vibrations," ASME J. Vib. Acoust., 126, pp.202-211.
- 5) Den Hartog, J. P., 1931, "Forced Vibrations with Combined Coulomb and Viscous Friction," Trans. ASME, 53, pp. 107–115.
- 6) Hundal, M. S., 1979, "Response of a Base Excited System with Coulomb and Viscous Friction," J. Sound Vib., 64, pp. 371–378.
- 7) E.S. Levitan, 1960, "Forced Oscillation of a spring-mass system having combined Coulomb and Viscous damping," Journal of the Acoustical Society of America 32, pp.1265-1269.
- 8) Thomas A. Perls and Emile S. Sherrard 1956, "Frequency Response of Second Order Systems with Combined Coulomb and Viscous Damping," Journal of Research of the National Bureau of Standards, 57, pp.45-64.
- 9) J.W.Liang, and B.F., Feeny, 1999, The Estimation of Viscous and Coulomb Damping in Harmonically Excited Oscillators," Proceedings of DETC 99, Las Vegas,