



---

## Automatic Access Control System using Arduino and RFID

Orji EZ\*, Oleka CV, Nduanya UI

Computer Engineering, Enugu State University of Science and Technology, Enugu, Nigeria

**Abstract** Wireless security based applications have rapidly increased due to the dramatic improvement of modern technologies. Many access control systems were designed and/or implemented based on different types of wireless communication technologies by different people. Radio Frequency Identification (RFID) is a contactless technology that is widely used in several industries for tasks like access control system, book tracking in libraries, tollgate system, supply chain management, and so on. In this paper, automatic RFID-based access control system using Arduino was designed. The system combines RFID technology and Arduino to accomplish the required task. When the RFID reader installed at the entrance detects an RFID tag, the system captures the user unique identifier (UID) and compares it with the stored UID for a match. If the user UID captured match with any of the stored UID, access is granted; otherwise access is denied. The results clearly show that the system is cheap, effective, and a reliable means of granting or denying access in a secured environment.

**Keywords** Arduino, RFID, Access Control, Arduino IDE, UID, Sensors

---

### 1. Introduction

Security systems play an important role to prevent unauthorized personnel entry into a secured environment, which may include physical and intellectual property. Various door locks such as mechanical locks or electrical locks were designed to attain basic security requirements. Basically, these locks can be easily hacked by unwanted people thereby allowing unauthorized personnel into secured premises.

Automatic access control system has become necessary to overcome the security threats faced by many organizations in Nigeria. By installing the system at the entrance will only allow the authorized personnel to enter the organization. The system is not restricted to main entrance installation, but can be installed at various entrances within the organization to track personnel movement thereby restricting their access to areas where they are not authorized.

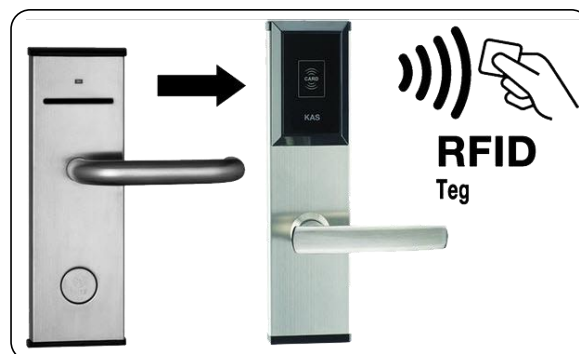

Figure 1: RFID Based Door Lock System [1]



There are several automatic access control technologies including barcode, magnetic stripe and Radio Frequency Identification (RFID) applied in security system. Radio-Frequency Identification (RFID) is an emerging technology and one of the most rapidly growing segments of today's access control. RFID technology, offers superior performance over other automatic identification systems and is used in many areas such as public transport, ticketing, animal identification, electronic immobilization, industrial automation, access control, asset tracking, people tracking, inventory detection and many more [2].

Figure 1 show two different ways access control system can be accomplished. Use of keys which is old method and by use of RFID technology. This paper discusses the design of an automatic access control system using Arduino microcontroller and RFID system. The aim is granting access to authorized personnel and denying access to unauthorized personnel by using RFID technology instead of keys as shown in figure 1. Each person is issued an authorized tag, which can be used for swiping in front of the RFID reader to have access to a secured environment.

## 2. Literature Review

Umar et al [3] proposed an RFID based security and access control system. It is the design of RFID based security and access control system for use in hostels inside Punjab University premises. The system combines RFID technology and biometrics to accomplish the required task. When the RFID reader installed at the entrance of the hostel detects tag UID, the system captures the user's image and scans the database for a match. If both card UID and captured image matches a registered user, access is granted; otherwise, access is denied and the system turns on alarm to alert the security personals. The advantage of the system is that it successfully accomplished security and control task by processing information from sub-controllers like; entrance monitoring controller, exit monitoring controller and mess monitoring controller installed at entrance gate, exit gate and mess gate respectively. Although the developed system is useful in reducing security threats to the hostels, there is a room for improvement in the response time of the system. The response time can be improved by using dedicated processors instead of computer systems capable of processing the images in real time.

RFID based access control security system with GSM technology was proposed by Peter et al [4]. The work was archived through the use of RFID system operating on 125 KHz frequency, microcontroller programmed to send control signals, DC motor, relay, buzzer, liquid crystal display (LCD), and GSM/GPRS modem. Once the RFID tag which contains the user's unique information is scan by the RFID reader and confirmed match with the information stored in the microcontroller, the microcontroller is instructed to turn on the DC motor, display user number and card number on the LCD and activates the GSM/GPRS modem to send an SMS alert about authorized user card to the security personnel. Else, the DC motor remained off, LCD displays invalid card, buzzer turns on for about 5seconds, and GSM/GPRS modem activated to send unauthorized user card to the security personnel.

## 3. Methodology

In this proposed work, the RFID reader reads the data from tag and sends the card UID number to Arduino microcontroller for comparison, if the card is valid then Arduino microcontroller display access granted else, access denied on the screen.

### 3.1. Hardware Overview

**RFID Technology** - RFID stands for Radio Frequency Identification and it's a non-contact technology that's broadly used in many industries for tasks such as personnel tracking, access control, supply chain management, books tracking in libraries, tollgate systems and so on [5].

Our RFID system consists of two main components, a tag which is located on the RFID card one want to be identified, and a transceiver or a reader which is installed at the secured entrance.

Our system RFID reader consists of a radio frequency module, a control unit and an antenna coil which generates high frequency electromagnetic field as shown in figure 2. On the other hand, the tag used in this work is a passive component, which consists of just an antenna and an electronic microchip, so when it gets near the electromagnetic field of the transceiver installed at the secured entrance (2 to 5 inches), due to induction, a



voltage is generated in the tags' antenna coil and this voltage serves as power for the microchip of our system tag.

Now as the tag is powered, it can extract the transmitted message from the reader, and for sending message (UID) back to the reader, it uses a technique called load modulation. Switching on and off a load at the antenna of our tag will affect the power consumption of the reader's antenna which can be measured as voltage drop. These changes in the voltage will be captured as ones and zeros and that's the way the data is transferred from the tag to the reader.

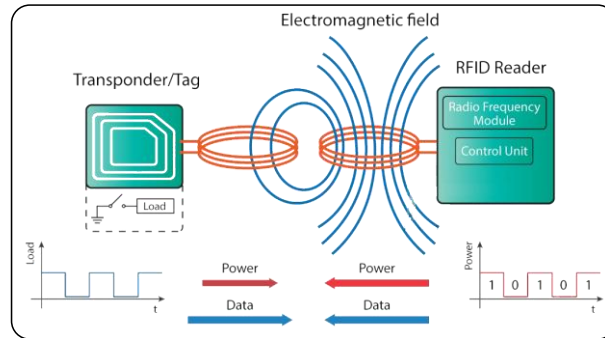

Figure 2: RFID Working Principles [5]

### How the reader reads the tag

We have one RFID tag with UID (B0 A5 8D 7C) and for RFID reader to get such information from the tag it needs to be converted from hexadecimal value to binary as shown in **table 1**.

**Table 1:** UID - B0 A5 8D 7C Conversion

Hexadecimal value	Binary value
B	1011
0	0000
A	1010
5	0101
8	1000
D	1101
7	0111
C	1100

32 bit worth of data is transferred from the tag to the reader in binary form (1011 0000 1010 0101 1000 1101 0111 1100). This data is transferred using high frequency (HF) 13.56MHz, which is the frequency that our RFID system operates on.

**Arduino Uno Board** - The Arduino Uno is a microcontroller board based on the ATmega328. It has 14 digital input/output pins (of which 6 can be used as PWM (pulse width modulation) outputs), 6 analog inputs, a 16 MHz ceramic resonator, a USB (universal serial box) connection, a power jack, an ICSP (in-circuit serial programming) header, and a reset button. It contains everything needed to support the microcontroller; simply connect it to a computer with a USB cable or power it with an AC-to-DC adapter or battery to get started [6].

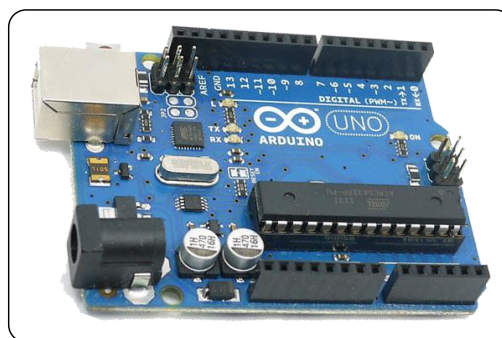

Figure 3: Arduino Uno Board



The Arduino UNO board in figure 3 can be toyed without been concerned about doing something wrong with the board, worst case scenario the chip can be replaced with a new and cheap one and start over again.

### 3.2. Software Overview

**Arduino IDE** – The IDE (Integrated Development Environment) is a special program running on computer that allows one to write sketches for the Arduino board in a simple language modeled after the Processing language [6].

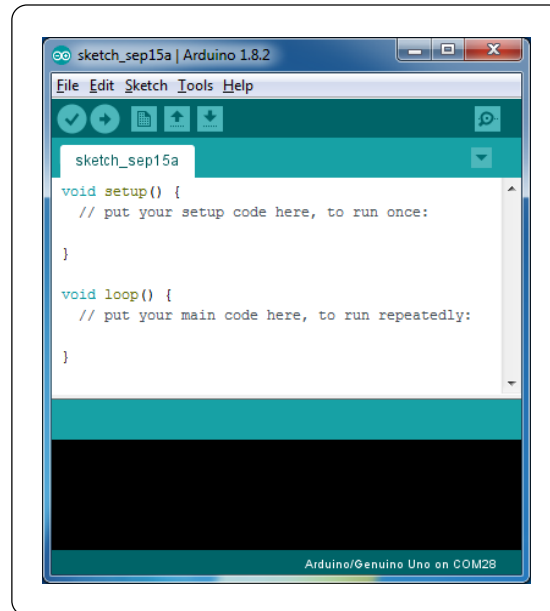

Figure 4: Arduino IDE

To program the Arduino microcontroller Arduino coding language was used. The Arduino language is based on C/C++ and the most basic executable program only needs two functions as shown in **figure 4**, a `setup()` and a `loop()`, to run. In the `setup()` function variables, pin modes, serial communication, etc are initialized. This function only runs once. The `loop()` function is where one write the actual code. As the name implies, the `loop()` function loops continuously until the device is powered off. Simple as it may sound; it is possible to write complex programs using the above described structure.

### 4. Working of the System

Before we start our automatic access control system using Arduino and RFID project, let's take a look at the system block diagram and the flow chart of the project.

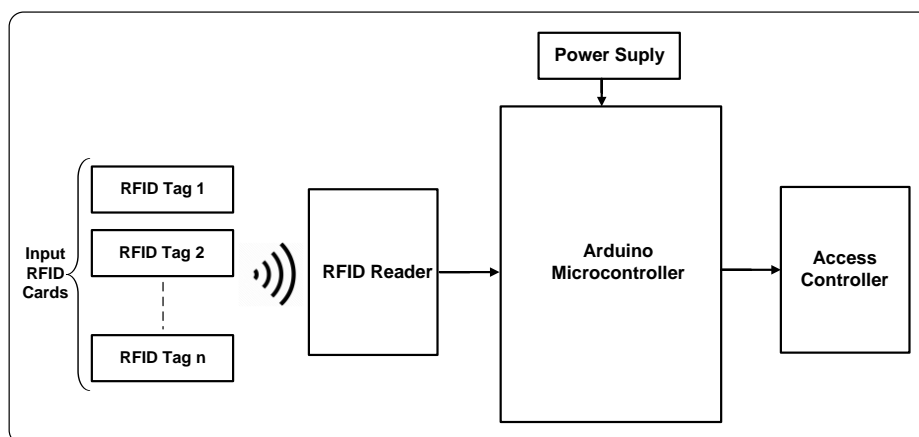

Figure 5: System Block Diagram



Figure 5 shows the access control system block diagram using Arduino and RFID. The system has three separate parts, an RFID reader, a microcontroller, and an access controller. The RFID reader reads the RFID tags and the microcontroller accept the data from the reader process it and use the result to either grant or deny access to the user using access controller. The project can be enhanced by connecting an LCD display to display if access is granted or denied instead of serial monitor.

#### 4.1. Control Flow

All necessary information about all users is stored in the system. In other to add a new user, we must first register the user with the system then, corresponding user information is burn in RFID tag. The new tag will now be accessible through the system.

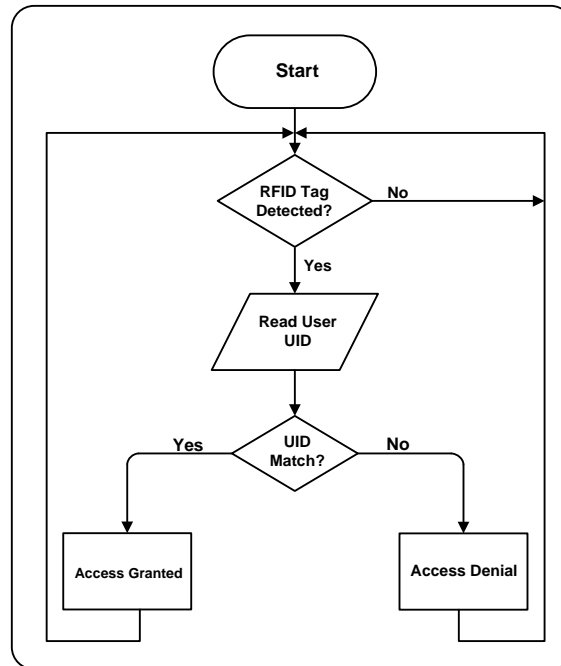

Figure 6: Control Flow Diagram

When a user comes to the entry point where the RFID reader is installed and places the RFID tag close (contactless) to the reader, the system checks whether it is a registered user or not. If the user is registered, the tag information is matched with the user information stored in system as shown in figure 6. Access is granted to such user while access is denied to unauthorized user see figure 6.

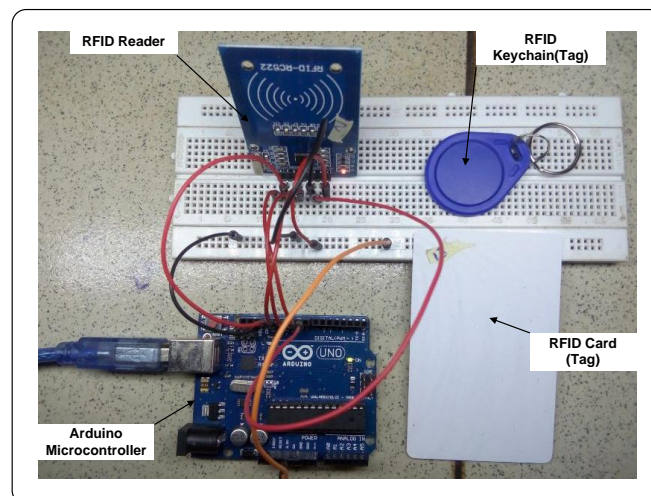

Figure 7: Automatic Access Control prototype using Arduino and RFID



In figure 7, when the RFID tag is placed close to the RFID reader, access is granted or denied. The right tag stored on the microcontroller grants access to the secure environment while the wrong tag not stored on the microcontroller will deny access to the card holder. Access granted or denied is displayed on the serial monitor as shown by figure 9.

**Table 2:** Connection of the RFID Reader with Arduino Microcontroller

RFID Module	Arduino
SDA	Digital Pin 10
SCK	Digital Pin 13
MOSI	Digital Pin 11
MISO	Digital Pin 12
IRQ	No Connection
GND	GND
RST	Digital Pin 9
3.3V	3.3v

Table 2 shows how the Arduino is interfaced with the RFID reader. Also note that 3.3v of the RFID module must be connected to 3.3v on the Arduino board not 5v. With the above connections, the Arduino is ready to take commands and execute accordingly.

#### 4.2. Programming the Arduino Board

The Arduino board was programmed through Arduino IDE and this paper captured the necessary code.

The loop() starts with a few lines of code that are looking for input, if there are no user input the device will do nothing but wait.

```
void loop()
{
  // Look for new cards
  if ( ! mfrc522.PICC_IsNewCardPresent())
  {
    return;
  }
  // Select one of the cards
  if ( ! mfrc522.PICC_ReadCardSerial())
  {
    return;
  }
  //Show UID on serial monitor
  Serial.print("UID tag :");
  String content= "";
  byte letter;
  for (byte i = 0; i < mfrc522.uid.size; i++)
  {
    Serial.print(mfrc522.uid.uidByte[i] < 0x10 ? " 0" : " ");
    Serial.print(mfrc522.uid.uidByte[i], HEX);
    content.concat(String(mfrc522.uid.uidByte[i] < 0x10 ? " 0" : " "));
    content.concat(String(mfrc522.uid.uidByte[i], HEX));
  }
  Serial.println();
  Serial.print("Message : ");
  content.toUpperCase();
  if (content.substring(1) == "B0 A5 8D 7C") //change here the UID of the card/cards that you want to give
  access or add multiple tags
  {
    Serial.println("Welcome Zeluwa your access is Authorized");
    Serial.println();
    delay(3000);
  }
}
```



```

else {
  Serial.println("Sorry Access denied!");
  delay(3000);
}
}

```

Figure 8: Code Listing

Once the program sees the correct combination of tag UID it will grant access to the user. While access will be denied to incorrect tag UID or tags that are not store in the system. Tag UID can be added or remove by admin through the IDE and re-uploaded back the Arduino board for effective operation.

#### 4.3. Results

The project has the following workflow: on arriving at the door where the access control is installed, one is asked to approximate their RFID tag to the reader as show on the output window (see figure 9). The reader reads the tag and the microcontroller compare the tag's UID for match and grant access if there is a match and deny access if there is no match.

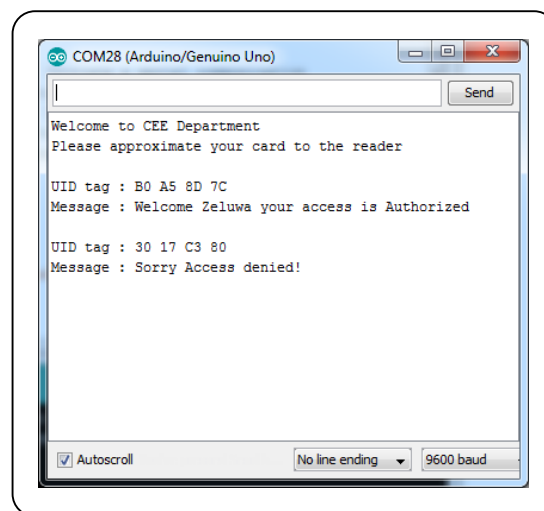

Figure 9: Output through serial monitor

An RFID tag can be added or removed through the Arduino IDE or any other programming language that Arduino understands. For changes made on the sketch (i.e. adding or removing a tag) to be effective on our system, the sketch must be re-uploaded to the Arduino board to override previous sketch.

#### 4.4. Access Control System Analysis

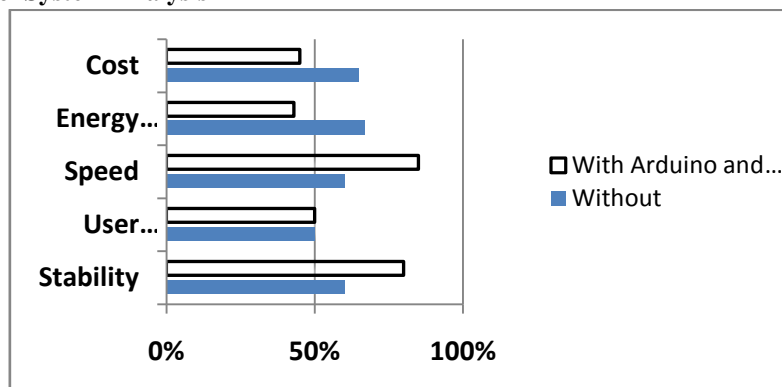

Figure 10: Access Control System with Arduino and RFID and without

Access control system was analyzed using the following criteria: cost, energy consumption, speed, user satisfaction, and stability. The bar chart (figure 10) shows that there are significant enhancements in access





control system using Arduino and RFID technology. The enhancements come in the area of cost, energy consumption, speed, and stability. Other access control systems have high energy consumption rate which is a great problem in Nigeria where energy is very expensive, while the users of the system have equal satisfaction in both systems.

## 5. Conclusion

In this paper, a prototype of automatic access control system for use in an environment is presented. The system uses radio frequency identification (RFID) with Arduino technology to differentiate between authorized and unauthorized users. The RFID reader reads RFID tag issued to the user and matches it with stored UID on the Microcontroller. On a successful match, the microcontroller grants access or deny access if no match was found. An automatic access control system using Arduino and RFID has been prototyped and functioned as desired. The system can be installed at the entrance of a secured environment to prevent an unauthorized individual access to the environment.

## References

- [1]. Tarun Agarwal, (2015), "RFID based Automatic Door Lock System with Arduino", Retrieved 19 October 2017, from <https://www.elprocus.com/automatic-door-lock-system-using-rfid-and-arduino/>.
- [2]. Ramalatha, M., Ramkumar, A. K., Selvaraj, S. and Suriyakanth, S, (2014), "RFID Based Personal Medical Data card for Toll Automation". Elysium Journal Engineering Research and Management. Volume1, ISSN: 2347-4408, pp 51-52.
- [3]. Umar Farooq, Mahmood ul Hasan, Muhammad Amar, Athar Hanif, and Muhammad Usman Asad, (2014), "RFID Based Security and Access Control System" IACSIT International Journal of Engineering and Technology, Vol. 6, No. 4, August 2014.
- [4]. Peter Adole1, Joseph M. Môm and Gabriel A. Igwue, (2016), "RFID Based Security Access Control System with GSM Technology", American Journal of Engineering Research (AJER) e-ISSN: 2320-0847 p-ISSN: 2320-0936 Volume-5, Issue-7, pp-236-242.
- [5]. Dejan Nedelkovski, (2017), "How RFID Works and How To Make an Arduino based RFID Door Lock - HowToMechatronics", Retrieved 15 October 2017, from <http://howtomechatronics.com/tutorials/arduino/rfid-works-make-arduino-based-rfid-door-lock>
- [6]. <http://howtomechatronics.com/tutorials/arduino/rfid-works-make-arduino-based-rfid-door-lock>
- [7]. Massimo Banzi, "Getting Started with Arduino" USE, Dale Dougherty, 2009.

