

Coordination of Energy Storage Units and Distribution Network Loading Management by Distributed Control strategy

C.Prakash¹, DR. Rathanakumar²

¹PG Scholar, ² Professor, Department of Electrical and Electronics Engineering, SCSVMV University, Enathur, Kanchipuram- 631561

Abstract:

This project proposes a distributed control approach to coordinate multiple energy storage units (ESUs) to avoid violation of voltage and network load constraints. ESU as a buffer can be a promising solution which can store surplus power during the peak generation periods and use it in peak load periods. In ESU converters both active and reactive power are used to deal with the power quality issues in distribution network. ESU's reactive power is proposed to be used for voltage support, while the active power is to be utilized in managing network loading.

I.Introduction

As a sustainable solution for future energy crisis, it is anticipated that future distribution networks will see a widespread use of renewable energy sources such as PV, wind turbine and fuel cell. Distribution networks with renewable energy sources can encounter two main challenges. A typical load curve for NSW shows that during the peak load period, generation is normally low or zero, which may cause voltage drop along the network. On the other hand, in peak generation period, when generated power exceeds the load, surplus power is injected to the grid. This will cause reverse power and hence may result in voltage rise along the network. Additionally, in both peak generation and peak load periods, thermal constraints for line and power transformer can be violated.

The unbalance between the generated power and load, during both the

high load and high generation periods, causes the noted issues. As a result, the introduction of energy storage unit (ESU) as a buffer can be a promising solution which can store surplus power during the peak generation periods and use it in peak load periods. The main challenge in the utilization of multiple ESUs is the coordination control strategy. There are three types of coordination strategies that can be taken. The strategy can be provided through centralized manner in which a central controller coordinates ESUs. The drawback of this approach is that it would require extensive data base with high speed and fast calculating computers, along with broadband networks. This can be too expensive for the current state of art. This can also be less reliable due to communication failure and computer freezing. The second approach is the localized control strategy, based on local measurements only. This control strategy is robust in the sense that

B. Localised Control Strategy

In contained control strategy will be used to coordinate the contribution of PV inverters for voltage support using their active and reactive power. Different localized techniques are proposed for voltage support based on reactive power control. It is to be noted if a PV inverter VA rating is increased by just 11.8%, it will have the ability to supply 50% reactive power while supplying full rated power. Consequently, customers can use this capability for voltage reduction. The category which use inverter reactive power for voltage decrease can be summarized as follows:

- Fixed reactive power control: In this strategy, the inverter bus voltage is monitored. If the bus voltage goes above a predetermined limit, PV inverter starts to absorb a constant reactive power.
- Reactive power control as a function of inverter bus potential: This strategy is based on fixing the inverter bus voltage to a desired value by absorbing or injecting reactive power

C. Distributed control strategy

Consensus algorithm is projected for distributed control method and to coordinate ESUs within the LV network for efficient voltage reduction while avoiding curtailment. Since single-phase PVs in a particular phase can cause voltage rise in that phase, the algorithm is applied in per phase basis. Consider a phase that has n distributed ESUs.

- Between $t=t_1$ and $t=t_2$, the critical node voltage is within desirable voltage range. Consequently, the network is in normal operation condition. In this instant, all PV inverters are injecting maximum available active power and their reactive power is based on characteristics. Moreover, ESUs are controlled by customers EMS.
- At $t=t_2$, the upper critical voltage limit is violated in the critical node. Therefore, PV inverters, whose bus voltages pass

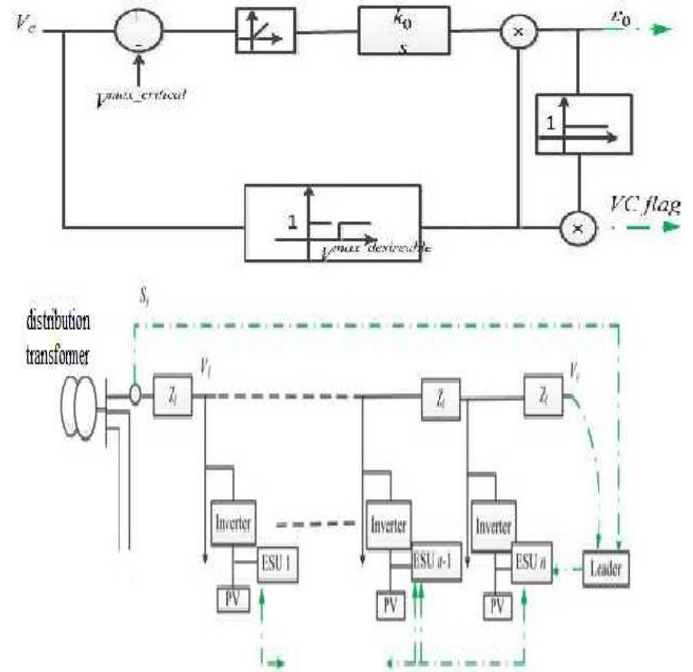

Communication structure

D. Control Objective:

Radial LV network, the last node is the critical node. If the customers in this node do not experience any voltage limit violation, all other customers on the same phase will not face voltage problem. The coordinated control strategy is illustrated in fig, based on the voltage of this node. The chronological course of events is described as follows

this, start to curtail their active power base. In summing, the leader initiates the communication among ESUs to find their contribution for voltage reduction.

- Based on the communication speed, at $t_3 + \Delta t$, the ESUs reduce the voltage of critical node below the upper critical limit, which results in preventing RE curtailment.
- At t_4 , voltage of the critical node falls back in the desirable range which means the voltage of all nodes is in desirable range. As a result, VC flag becomes 0 and ESU control strategy is changed back to function based on customer's EMS command

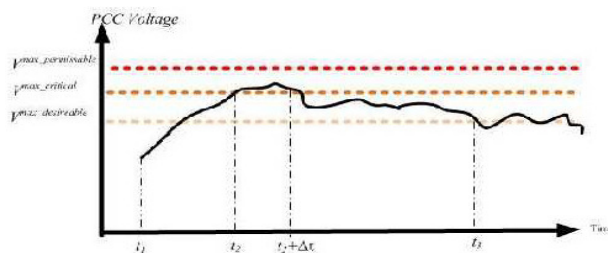

F. Distributed Control Scheme

The distributed control strategy for each ESU can be written in a general form as: $u_i = f_i(c_{i0}(t), \epsilon_0(t), c_{i1}(t), \dots, c_{in}(t), \epsilon_n(t))$

where $c_{ij}(t)$ denotes the communication link between i th and j th ESUs, $c_{ij} = 1$; if j th ESU send information to i th one, otherwise $c_{ij} = 0$. In addition, $c_{i0} = 1$; if the i th ESU can get information from the leader, otherwise $c_{i0} = 0$. $c_{ii} = 1$ for all ESUs

This time-varying coefficients can be represented as a matrix presenting the whole communication topology as in equation .

$$C(t) = \begin{bmatrix} c_{10}(t) & c_{11}(t) & \dots & c_{1n}(t) \\ \vdots & \vdots & \ddots & \vdots \\ \vdots & \vdots & \ddots & \vdots \\ c_{n0}(t) & c_{n1}(t) & \dots & c_{nn}(t) \end{bmatrix}$$

Two general objectives need to be achieved to coordinate ESUs when required. The first is to design a control for u_i of each ESU to reduce the network apparent power to less than its critical limits. In other words, in peak load period, ESUs need to be coordinated to bring the value of $S(t)$ to less than $S_{load_critical}$, as shown in equation Similarly, in peak generation period equation needs to be met.

$$S(t) < S_{load_critical} \quad (1.1)$$

$$S(t) < S_{gen_critical} \quad (1.2)$$

The second objective is to design a control for u_i to share the required active power according to the same ratio among ESUs, as shown in equation (1.5).

$$\frac{P_{ESU_1}}{P_{ESU_2}} = \frac{P_{ESU_2}}{P_{ESU_3}} = \dots = \frac{P_{ESU_n}}{P_{ESU_n}} \quad (1.3)$$

In real case, the interaction among ESUs occurs at discrete time step td . Therefore, the information state of each ESU is updated using equation (3.6).

$$\epsilon_i(t) = \sum d_{ij} \cdot \epsilon_j(t - t_d) \quad (1.4)$$

$$\sum C_{d_{ij}} = \frac{C_{ij}(t - t_d)}{\sum_{j=0}^n C_{ij}(t - t_d)} \quad (1.5)$$

$$P_{ESU}(t) = \epsilon_i(t) \times P_{ESU_i} \quad (1.5)$$

III. Proposed approach of distributed control strategy

The dashed arrows the information flow, where the neighbouring ESUs are communicated to coordinate their operation. The proposed internal control structure for each ESU is shown in Fig. The reference value for ESU's active and reactive power (PESUi(t) and QESUi(t)) depend in information state of each neighbor. As noted before, the proposed control includes voltage and network loading management.

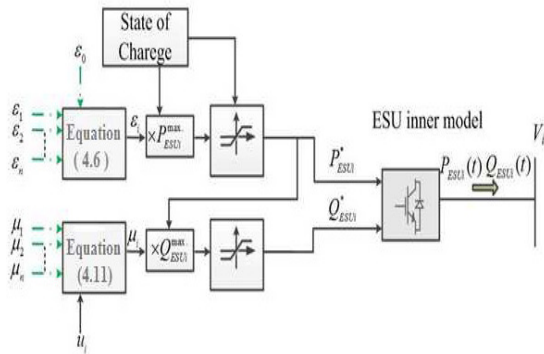

IV. Distributed control strategy flow chart

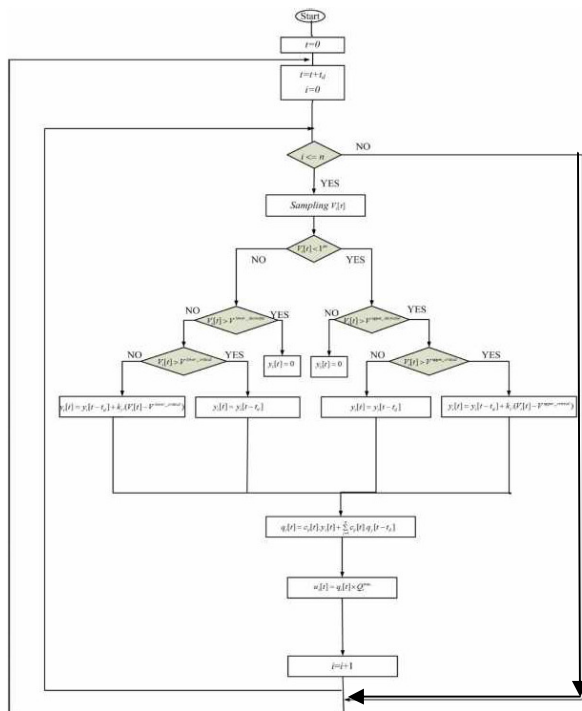

$$\mu_i[t] = s_{ij} \cdot \mu_j[t] + \sum_{j=N_i} s_{ij}[t] \cdot \mu_j[t - t_d]$$

V. Proposed localized voltage control for each ESU

With the proposed communication structure, the customers are only aware of the value of Dji corresponding to their neighbours. Therefore, the sensitivity matrix is modified as:

$$\overline{D_{ji}} = \begin{cases} D_{ji} & i \in \{N_i \cup j\} \\ 0 & i \notin \{N_i \cup j\} \end{cases}$$

Finally the transition weights are calculated by the following equation:

$$S_{ij}[t] = \frac{D_{ij} \cdot c_{ji}[t]}{\sum_{j=0}^n D_{ki} \cdot c_{ki}[t]}$$

As a result, the weights are predetermined for eachESU. If either of the critical voltage limits is violated for any ESU, its localizedcontrol term initiates the distributed control strategy based on

$$u_i(t) = k_{qi} (v_{\max_critical} - V_{i(t)}) \tag{1.6}$$

$$u_i(t) = k_{qi} (v_{\min_critical} - V_{i(t)}) \tag{1.7}$$

Following the control initiation, the information states of ESUs are updated in each discrete time interval based on equation. Finally, the required reactive power contribution of each ESU at each time interval is updated by:

$$Q_{ESU_i}[t] = \mu_i[t] \times Q_{ESU_i}$$

By applying this control structure, both objectives for voltage support can be achieved and ESU inverters will contribute with their reactive power.

$$\varepsilon_i(t) = \sum d_{ij} (t - t_d) \cdot \varepsilon_j(t - t_d)$$

$$Q_{ESU_i}[t] = \mu_i[t] \times Q_{ESU_i} \quad (1.7)$$

$$P_{esu_i}[t] = \varepsilon_i[t] \times P_{ESU_i} \quad (1.8)$$

$$Q_{ESU_i}[t] = Q_{ESU_i}(t) \quad (1.9)$$

$$P_{ESU_i}[t] = P_{ESU_i}(t) \quad (1.10)$$

Where equations 1.7 and 1.8 model the proposed distributed control strategy for ESUs, equations 1.9 and 1.10 model the ESUs internal control. It is worth noting that the internal dynamics of network are not considered here. So, it can be said that the value of these variables diminish much faster than the output power. As a result, the dynamic of ESU output power is determined by the controller designed in this paper while the inner dynamic of ESUs is ignored. Consequently, the ESUs reactive and active power are modelled

VI. Proposed Simulation Diagram For Coordination Of ESU

The proposed distribution control strategy architecture is developed with the coordinated communication link. In order to develop this architecture five

PV generation and the three energy storage units are considered. Let the energy storage unit (ESU-1) is placed in between the PV-1 and PV-2, the ESU-2 is placed in between PV-4 and PV-3 and the last ESU-3 is placed in between PV-4 and PV-5.

The general simulation diagram is shown in figure. In occurrence of voltage issues and the overload problems, the energy storage units are coordinated with the principle of distribution control strategy. With the coordination of energy storage unit we can overcome the voltage issues and network problems in the distribution network. The block diagram of subsystem of the energy storage unit is shown in next figure. This subsystem consists of inverter and the output of the whole subsystem is connected with the grid for overcome the voltage issues. Similarly, the identical subsystem is communicated with the each and every subsystem in the station.

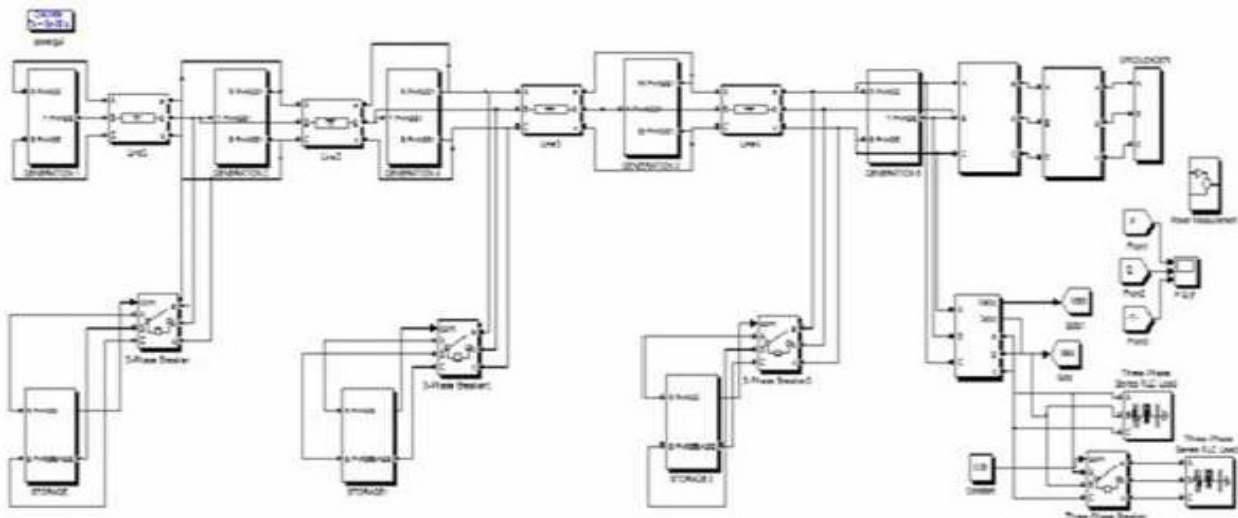

General Simulation Diagram

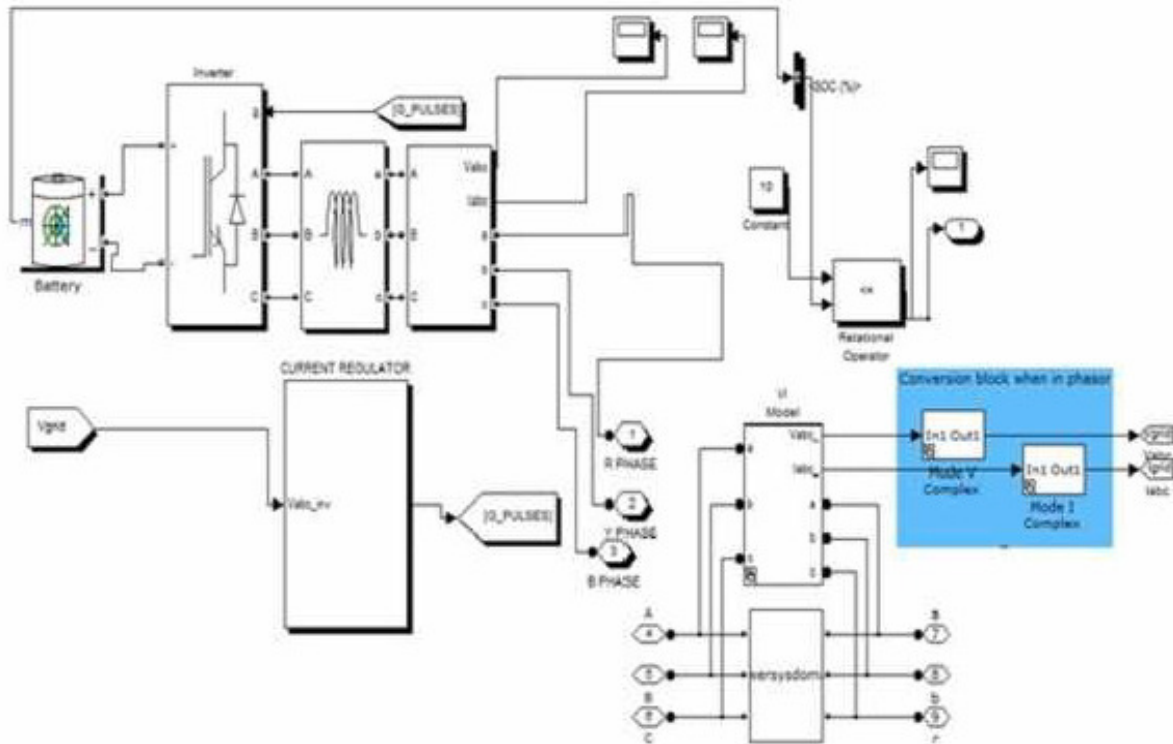

Simulation of Energy storage unit Subsystem

All the energy storage units are interconnected with the communication leader corresponding to the distributed control strategy. The resulting waveforms are presented, analyzed with the active and reactive power with respect to time.

a. System Parameters:

Parameter	Voltage (p.u)
$V^{\max}_{\text{permissible}}$	1.0
$V^{\max}_{\text{critical}}$	1.0
$V^{\max}_{\text{desirable}}$	1.0

The details about the parameter of the system such as PV generation ratings and the available active power for each generation units are shown in tables. The permissible and critical voltage limits and the network loading limits are shown in tables below.

b. Available active power for ESU voltage limit

PV	PV1	PV2	PV3	PV4	PV5
Active power	550	600	500	450	650

c. PV's ratings

ESU	ESU1	ESU2	ESU3
Active power	150	200	250

d. Network loading limits

Parameter	Power (kva)
$S_{max_permissible}$	2200
$S_{max_critical}$	1800
$S_{max_desirable}$	1500

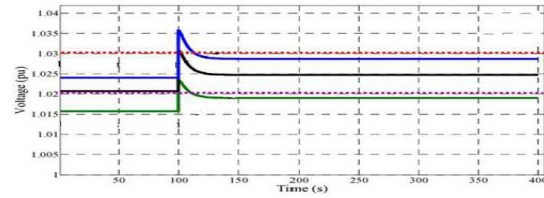

Energy storage unit bus voltage waveform

The waveform for the energy storage unit voltage power factor with respect to time is shown in Figure. The voltage is measured in terms of p.u. and it keeps on increasing monotonously.

It can be seen between $t=0s$ and $t=100s$, all voltages and network loading are in the desirable range. Therefore, no ESUs coordination is needed. However, at $t=100s$, as the PV generation increases, the upper critical limit for voltage of ESUs 2 and 3 and network loading is violated. Therefore, the proposed control approach for both voltage and thermal constraints management is initiated. To network loading management, it can be, at the equilibrium point, its value is less than upper critical limit.

VII. ANALYSIS OF SIMULATION RESULTS

The proposed power system model has been simulated in MATLAB / Simulink. The resulting waveforms for active power and reactive power are shown

a. Simulation Result For ESU's Bus Voltage And Network Loading Profile

The simulation results are discussed below for both ESU's bus voltage and reactive power on basis of distribution control strategy. Consider first the waveform for the active power. In addition, it is stipulated that the power factor of ESUs should be more than 0.9 and the upper limit of the reactive power output is dependent of the active power output as

$$Q_{ESU}^{max} = 0.4843 \times P_{ESU_i} \quad i = 1,2,3.... \quad (1.11)$$

It is assumed that all loads are in 15% of their maximum. In addition, the PVs generation change from 75% to 95% at $t=100s$.

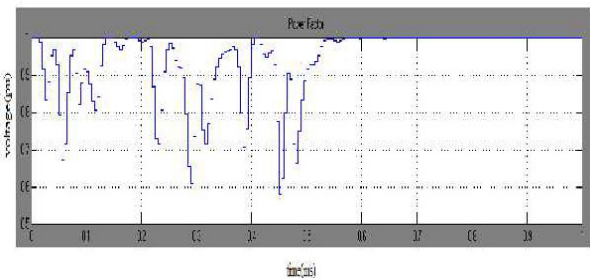

Power factor waveform of ESU

b. Simulation Results For ESU's Active And Reactive Power

Next, the resulting waveforms for each Energy storage units active

power and reactive power according to the distribution control strategy. In this case, the waveform reaches the stable condition and as shown below. Figure shows the active power of the generators using the controller. In this figure, the power first fluctuates and then achieves a stable state

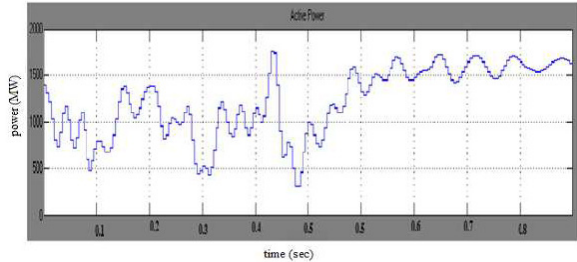

Energy storage unit active power waveform

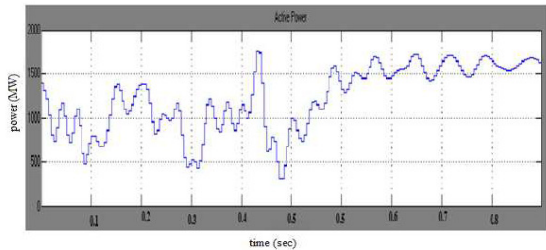

Energy storage unit reactive Power waveform

Figure shows the waveforms of the Energy storage unit reactive power for the three energy storage unit. The active power is measured in terms of p.u. and it attains the stable condition due to the presence of the distribution control

$$\left| \frac{Q_{ESU_3}}{Q_{ESU_3}^{\max}} \right| < \left| \frac{Q_{ESU_2}}{Q_{ESU_2}^{\max}} \right| < \left| \frac{Q_{ESU_1}}{Q_{ESU_1}^{\max}} \right|$$

After the generation step change, the ESU voltages follow the pattern based on equation. Accordingly, reactive power sharing among ESUs needs to follow as in to have effective voltage support. From the analysis of simulation results, it concluded that with the presence of distributed control strategy the terminal

voltage, reactive power, real power is reached the stability condition. Therefore, the main benefits of using this type of control has attained the steady state region earlier when compared with some other types of controlling strategy.

Conclusion:

Distribution control strategy is a new approach to coordinate multiple Energy storage units to manage voltage and loading in distribution networks.

This method is designed to use the most adjacent ESUs to the violated bus voltage and for loading management, a distributed control strategy based on consensus algorithm is employed to coordinate ESU's active power.

The proposed distribution control strategy has been designed to share the required active power with the same ratio among ESUs with respect to their available active power. The proposed structure can support any of the precieved options for the future network technology.

REFERENCES

1. Anna R. Di Fazio, Giuseppe Fusco, and Mario Russo "decentralized control of distributed generation for voltage profile optimization in smart feeders," IEEE Trans. Smart Grid, vol.4, no.3, pp.1586-1596, Sep. 2013.
2. Augusto C. Rueda-Medina and Antonio Padilha-Feltrin "distributed generators as providers of reactive power support a market approach," IEEE Trans. Power Systems, vol.28, no.1, pp.490-502, Feb. 2013.
3. Edson Luiz da Silva, Jonathan J. Hedgecock, Member, João Carlos O. Mello, and João Carlos Ferreira da Luz "practical cost-based approach for the

voltage ancillary service," IEEE Trans. Power Systems, vol.16, no.4, pp.806-812, Nov.2001.

4. Guerrero. J. M, Kai. S, Li. Z and Yan. X. (2011), 'A Distributed Control Strategy Based on DC Bus Signaling for Modular Photovoltaic Generation Systems With Battery Energy Storage,' Power Electronics, IEEE Transactions on, vol. 26, pp. 3032-3045.

5. Hideharu Sugihara, Kohei Yokoyama, Osamu Saeki, Kiichiro Tsuji, and Tsuyoshi Funaki "economic and efficient voltage management using customer-owned energy storage systems in a distribution network with high penetration of photovoltaic systems," IEEE Trans. Power Systems, vol.28, no.1, pp.102-111, Feb. 2013.

6. Katherine M. Rogers, Ray Klump, Member, HimanshuKhurana, Angel A. Aquino-Lugo, and Thomas J. Overbye "an authenticated control framework for distributed voltage support on the smart grid," IEEE Trans. Smart Grid, vol.1, no.1, pp.40-47, June 2010.

7. Mokhtari. G, Zare. F, Nourbakhsh. G, and Ghosh. A. (2012), 'A new DER coordination in LV network based on the concept of distributed control,' in Power Electronics for Distributed Generation Systems (PEDG), pp. 1-8.

8. ReinaldoTonkoski, Dave Turcotte, and Tarek H. M. EL Fouly "impact of high pv penetration on voltage profiles in residential neighborhoods," IEEE Trans. Industry Sustainable Energy, vol.3, no.3, pp.518-527, July 2012.

9. Sugihara. H, Yokoyama. K, Saeki. O, Tsuji. K and Funaki. T. (2013),

'Economic and Efficient Voltage Management Using Customer-Owned Energy Storage Systems in a Distribution Network With High Penetration of Photovoltaic Systems,' Power Systems, IEEE Transactions on, vol. 28, pp. 102-111.

10. Teng. J. H, Luan. S. W, Lee. D. J and Huang. Y. Q. (2013), 'Optimal Charging/Discharging Scheduling of Battery Storage Systems for Distribution Systems Interconnected with Sizeable PV Generation Systems,' Power Systems, IEEE Transactions on, vol.28, pp. 1425-1433.