

# Ac Drive Synchronization Using CAN Protocol

Jariwala Hiren<sup>1</sup>, Patel Chintan<sup>2</sup>, Prasad Kuldip<sup>3</sup>, Shukla Ankur<sup>4</sup>, Chaudhary Sarwar Ali<sup>5</sup>, Patil Hemant<sup>6</sup>

(Department of Electrical Engineering, Shroff S.R. Rotary Institute of Chemical Technology, Vataria )

## Abstract:

In spinning industry, AC-drives are needed to rotate in synchronized speed to achieve quality product. Because of the quick evolution of manufacturing processes, the demand for flexible automation systems is on the rise. To meet these, distributed motion control architecture based on intelligent drives and field bus communication tends more and more to replace the traditional solutions. Drive synchronization is necessary in industries where minor difference in rotary movement make major difference in product quality. Using CAN (Control Area Network) protocol we can drive multiple motor in synchronization with minimum transmission gap. A control area network (CAN) based multi-motor synchronized motion control system with an advanced synchronized control strategy is proposed. The strategy is to incorporate the adjacent cross-coupling control strategy into the sliding mode control architecture. In this project we are going to synchronize multiple AC motors using CAN protocol.

**Keywords — Control Area Network (CAN), Drive Synchronization, field Bus Communication.**

## I. INTRODUCTION

In textile mills, paper mills the multiple drive requirements to rotate synchronized to each other, for good quality product. If the drives not rotate in synchronize manner it effect on quality of product. Poor speed synchronization is directly effect on financial benefit of company. So the drives synchronization is requirement is necessary to easily operate and control. [1]

Aim of this project is synchronize drive each other using CAN protocol. This technology is used to speed synchronization of drives. This is applicable to many industries like packaging industry, spinning mills, steel plants, paper process plants. Where in all the motors synchronization using conveyer.

Spinning mills where multiple motors work at same time on a conveyor belt to draw clothes, it is necessary that all the motors there should run at same speed, so that balanced tension is gain so that damage of cloths is reduce. In this project motors are synchronized to make the differential speed error among multiple motors to zero. One motor acts as transmitter and all the other motors as receivers. If a particular speed was set in the transmitter then all other motors speed would be matched to the same speed of the main motor. The mode of communication will CAN protocol. Each motor has a closed loop feedback mechanism providing RPM reference by a shaft mounted IR sensor arrangement whose output is fed to the controller in the circuit. A display unit displays the full speed and one can enter the desired percentage with help of a HMI to obtain the required speed for all the motors. The pulse width output

from the microcontroller would be automatically adjusted to maintain the DC power to the motor such that the entered speed percentage matches the running RPM[2]

## II. CAN PROTOCOL

Controller Area Network (CAN) is Bosch originally developed the in 1985 for vehicle networks. In the past, automotive makers connected electronic devices in vehicles using point-to-point wiring systems. Makers began using more and more electronics in vehicles, which solution in large wire harnesses that were heavy and costly. Then they devoted wiring with in-vehicle networks, which decreased wiring cost, complexity, and weight. 'CAN', a high-integrity serial bus system for networking smart devices, came out as the standard in-vehicle network. The automotive industry fastly adopted CAN and, in 1993, it became the international standard known as ISO 11898. Since 1994, several higher-level protocols have been standardized on CAN, such as CAN open and Device Net. Other markets have widely adopted these additional protocols, which are now standards for industrial communications. This white paper concentrates on CAN as an in-vehicle network.

CAN open is a CAN-based communication system. It consists higher-layer protocols and profile specifications. A CAN open has been extremely developed as a standardized enclosed network with extremely flexible configuration capacity. It designed originally for motion-oriented machine control systems, such as handling systems. Today it is used in different application fields, such as medical equipment, off-

road vehicles, maritime electronics, railway applications, building automation.

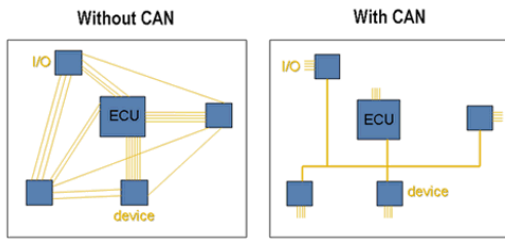

Figure 1 CAN Protocol

For example when we using CAN protocol it also reduce a wiring connection and easily operate machine, also communication to other part of machine and quickly operation, fast response, reduce machine size.

As stated earlier, CAN is a peer-to-peer network. This means that there is no master that commands when individual nodes have access to read and write data on the CAN bus. When a CAN node is prepare to transmit data, it checks to see if the bus is busy and then simply writes a CAN frame into the network. The CAN frames that are transmitted do not include addresses of either the transmitting node or any of the intended receiving node(s). Instead, an arbitration ID that is specific throughout the network labels the frame. All nodes on the CAN network receive the CAN frame, and, depending on the arbitration ID of that transmitted frame, each CAN node on the network determines whether to accept the frame.

If multiple choice nodes try to transmit a message into the CAN bus at the same time, the node with the highest priority (lowest arbitration ID) automatically gets bus access. Lower-priority nodes must wait until the bus gets available before trying to transmit again. In this way, you can implement CAN networks to assure deterministic communication among CAN nodes. [3]

### III. SYSTEM OPERATION

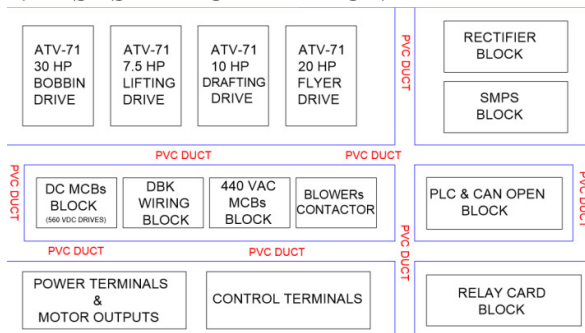

Figure 2 Architecture

A number of operations for a good quality of cotton in textile industry, like cleaning process, Ritter machine-1, Ritter machine-2, Speed frame, Ring frame, Auto corner, Winder, TFO, Final Winder. For this process using many drives to operate in synchronization with each other.

**Power terminal motor output:** This is main supply provide to whole system. A 440v ac power is here it will be convert in 24v dc for PLC and other equipment. Here also take output of all motors.

**Control terminal:** In control terminal unit there is separate NO (normally open) NC (normally close) switches. There also some signal terminal which is given signals to different process.

**NO NC switches:** - There is two emergency stop buttons on front and back side which use for stop whole system in emergency condition. A start and stop button is also provided here it operate when a system is ready. Traverse up and down lit button for lifting drive. To set a limit of drafting drive for up and down motion, when in some condition it cross limit then operate a push button and machine is stop. Cabinet open door front and back side this two button is check cabinet door is open it can't operate machine. Doffing mean removal of full bobbin and mounting of empty tubes. When working this process other process is stop only working this process, after doffing process again work whole drives.

- a **Signal system:** In this system used different LED when give signal under different condition.
  - b **Ready signal:** It gives when whole system is ready for work.
  - c **Machine ready & machine faulty:** When machine is ready for proper operation it give machine ready signal. When some fault occurs in machine it on another LED and machine ready LED is off.
  - d **Doff complete:** At a doffing process it give that signal, when process complete it will be off.
  - e **Roving brake:** When thread wound on yarn, the amount of thickness of thread is set, when some problem occurs, it gives signal.
  - f **Lifting brake signal:** When lifting drive cross set limit on upper and lower side it will damage yarn rotating design or thread will be brake, at this condition it give a signal.
- C. **RELAY CARD BLOCK:** In relay card block also three sub block. One block is contain different relay for physical equipment, this card block have a different relay e.g. stop front back side relay; flyer cover relay; cabinet door open front side and back side relay; stop motion back relay; this all relay are connect with PLC. Second block is containing different relay for drives. E.g. stop motion front side relay; traverse upper lower side limit relay; doff reset relay. A third block contain different relay for machine e.g. system ready to contactor; machine ready and faulty relay; doff complete relay; lifting brake relay. This all relay is connect with signal system used control terminal. So that it also give a signal and action on faulty condition.
- D. **PLC & CAN OPEN BLOCK:** A PLC & CAN open block put A PLC and CAN terminal in this block.
- a. **PLC:** - It is work on 24v dc, here we use snider PLC. An all command is given to PLC, according to

command it take an action on that particular equipment.

- b. **CAN OPEN:** - There is two port of CAN protocol one is connecting with PLC and another port is connect with different drives. According to that construction we decrease a wiring connection of motor, it direct operate on signal system. With using can protocol whole system is operate in sequence wise. It gives more efficiency and power saving technology.
- E. **RECTIFIER\_BLOCK:** - Rectifier is a device that converts AC to DC. Here rectifier is use for convert 240v AC to 24v DC. PLC works on 24v DC so that voltage is converting in dc.
- F. **SMPS\_BLOCK:** - Switched Mode Power Supplies is used for DC to DC supplies. The SMPS act as a continuously variable power converter and hence efficiency is negligibly affected by the voltage difference.
- G. **Protection block:** - In this block use different protection scheme for machinery. For 560v dc v DC drive protection put DC MCB. Which protect drive from abnormal faults? There is also protection of 440v AC motor put AC MCB. This MCB are connecting with blower contactor. All MCB and contactor are connecting with control terminal and PLC.
- H. **DRIVES:** In figure 3 shows a drive position in spinning mills. Here all drives are synchronization with each other through CAN protocol

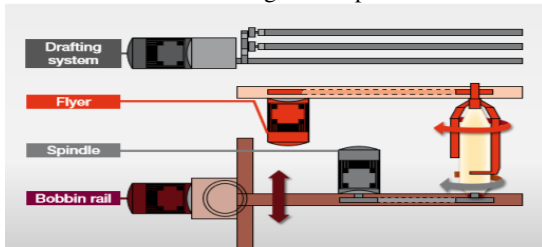

Figure 3 Drive Position

1. **Bobbin drive:** In this panel use a 10 section, 2 section connected with one motor. 1 section have 12 position
2. **Flyer drive:** Bobbin drive and flyer drive is connected in same direction. But bobbin drive rotate faster than flyer drive because a cotton thread wound on bobbin drive. The main working of flyer drive is twisted a cotton thread as a require size. A require size is measure to reference 1 meter. How it will be require in TPI (twist per inch) how much TPI we require. To wound a thread on bobbin first set rowing count and TPI (twist per inch) for taper angle winding.
3. **Drafting drive:** This drive is used for draft cotton on flyer drive. Cotton carried by a drafting drive is thick and huge cotton thread. A cotton thread deliver after twisting process is thin and smooth thread.

4. **Lifting drive:** - This drive is used for yarn to lift up and down direction. A limit is set on program how much mm yarn lift. It is used for thread wound on proper design.

#### IV. Conclusion

In this paper, the CAN-bus based automation and control system for milk industry is designed. Which is low cost, high reliability and other features to meet the needs of the modern automobile industry. To overcome the limitations and the weakness of centralized control system, such as difficulties for system modification and installation and wiring cost, serial communication systems known as CAN-protocol based systems have been developed. This paper presents a brief overview of CAN protocol network. This network is gaining high ground in many applications from packaging industry, spinning mills, automobile industry to automation industries. CAN is a multi-tasking serial bus that allows an efficient transmission of data between different nodes. With its flexibility and robustness against electrical intervention and also Digital control on the CAN Nodes is an important criterion industrial automation.

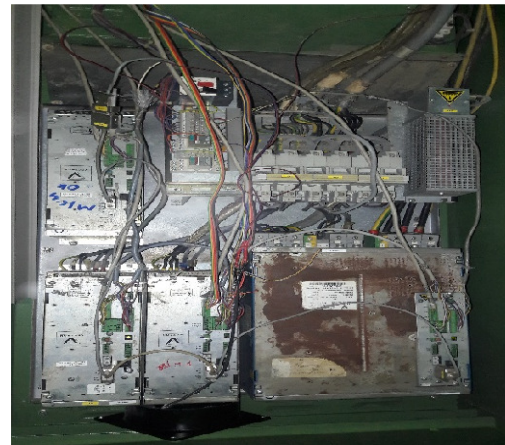

Figure 4 without CAN



Figure 5 with CAN Protocol

Here in figure 4 shown that spinning mill that without CAN protocol use more wiring also join extra equipment for protection purpose. We update that plant using CAN protocol

so that wiring is reduces and cost and maintenance also reduce. So that overall wiring construction is easy. In CAN protocol we use CAN cable it is an interfacing media between drives, PLC & HMI.

### **Reference**

- [1]. Edgex kit & solution (online),  
Available:<http://www.edgexkits.com/>
- [2]. Edgexkit Technologies Pvt. Ltd., “Speed synchronization of motor in industry”, Model: 231, Liberty Plaza, Himayathnagar, Hyderabad – 500029.
- [3]. National Instruments “Control area network overview”  
Aug 01, 2014
- [4]. Mr Abhijit K Chougule, Prof. R.J. Vaidya” Milk Dairy Automation Using CAN Protocol: A Paradigm for Industry Automation” Volume 3, Issue 9, ISSN: 2277 128X International Journal of Advanced Research in Computer Science and Software Engineering, September 2013
- [5]. Zweigniedrlassung der saurer Germany Gmbh & co. (online)  
Available: <http://www.saurer.com/en/saurer-welcome/>