

Design of System Agenda Module for Prospective Employee Selection

Nia Rahma Kurnianda

Faculty of Computer Science, Universitas Mercu Buana, Jakarta, Indonesia
Email: nia.rahma@mercubuana.ac.id

Abstract:

PT Persada is a company engaged in labor outsourcing. Variables such as client, workforce, job, as well as the number of selection processes complicate problems received. There are several problems we found of the selection process agenda. So we try to design a system to manage the problems. The basic theories we used in this study are IS, UML, Human Resource and Selection, SMS Gateway and our previous study. The result of this study is presenting as a design of information system with integration of web based and SMS Gateway solutions.

Keywords — Selection Agenda, UML, Web Based SMS Gateway System, HRIS Module, Information System Module

I. INTRODUCTION

PT PERSADA is a company engaged in labor outsourcing. Who has managed more than hundreds of clients and their workforce every year. Variables such as client, workforce, job, as well as the number of selection processes complicate problems received whenever there is a need for new employees at the company's client. Therefore, in completing the multi variables, we strive to make the related processes become mutually integrated with the ease of information technology.

However, the problems we found such as human error, in each selection process there are roles that are interrelated. Where in each move of the process makes a gap for miss communication between one part to another. Like the issue of publishing a schedule, the candidate is not called and the most severed one is candidate is not fulfilled. The most important problem number two is difficulties of administration. Difficulties in administration are divided into administrative selection files, candidate searches, candidate calls, recapitulation of each running process, results tracking and making process reports.

The most important goal is to provide optimization of each related process and increase efficiency in the process so that it can increase the productivity of the company which will certainly increase revenue. So we think we do have the work to solved are **1. What kind of system module that can bridge the management of these needs? 2. How will the system work to optimize each related process?**

To make it easier for us to follow each of the research processes, we divide the writing of the results of this study into 5 parts: **1. Introduction**, contains background, problems, purpose of writing, work to be completed and systematics of writing. **2. Fundamental Theories**, contains the theories used in research and previous studies that are related or support this research. **3. Research method**, contains research steps and methods and instrumentation used. **4. Results and discussion**, contains the results and discussion of the study. **5. Conclutions**, contains conclusions from the study.

II. FUNDAMENTAL THEORIES

A. Information System

An information system can be defined technically as a set of interrelated components that collect (or retrieve), process, store, and distribute information to support decision making and control in an organization. In addition to supporting decision making, coordination, and control, information systems may also help managers and workers analyse problems, visualize complex subjects, and create new products.^[1]

B. Unified Modeling Language

According to Dennis, Unified Modelling Language (UML) is the standard language for visualization, specification, construction and documentation of the artefacts of a software, and can be used for all stages in the system development process from analysis, design to implementation, according to Denn^[2].

UML provides some standard notation and diagrams that can be used as a communication tool for system developers in the process of system analysis and design. Diagrams in UML are defined as information in various forms that are used or produced in the software development process.

Based on the perspective in object-oriented analysis and design process with UML, there are several main diagrams in UML that can be used, namely: **1. Use Case Diagram.** Describe the expected functionality of a system. **2. Activity Diagram.** An analysis model used or describes an activity process **3. Sequence Diagram.** illustrates the objects in use cases and messages that run in a use case and **4. Class Diagram** Describes the number of classes and relationships between classes in the system.

C. Human Resource, Recruitment and Selection

As for Siagian, Human Resources (HR) are central factors in an organization or company. Whatever the form and purpose, the organization or company is made based on the vision for human interest and in carrying out its mission is managed and managed by humans^[3]

According to Marwansyah Recruitment is the process of attracting people or applicants who have the right interests and qualifications to fill certain positions or positions.^[4] In the recruitment process, there are various sources of recruitment,

marwansyah also stated in general, the source of recruitment can be classified into two types, namely: a. Internal recruitment, That is recruitment that is done using internal sources or employees who are already in the company. There are several methods used in internal recruitment, including job posting, employee references and succession plans. b. That is recruitment that is done by looking for workers from outside the organization or company because often existing employees do not meet recruitment needs for specific interests or purposes. External recruitment is usually carried out especially if the organization or company needs to fill entry level positions, requiring skills or skills that are not owned or required, requiring workers with different backgrounds to get new ideas.

If a group of applicants has been obtained through recruitment, the selection process starts from receiving the application and ends with a decision on the application. The employee selection process is one of the most important parts of the entire HR management process. According to Prof. Dr. Sondang P. Siagian, MPA in the selection process there are several stages that are usually taken, including among others: a. Receipt of application letter, b. Organizing examinations, c. Selection interview, d. Checking the background of the applicant and the reference letters, e. Health evaluation, f. Interview by the manager who will be his immediate supervisor, g. Introduction to work, h. Decision on application

D. Gammu SMS Gateway Application

Gammu is an application to build an SMS Gateway.^[5]

The application is currently managed by Michal Cihar and people who

experienced in making Gnokii and MyGnokii applications. All services on Gammu have their respective roles, such as services calls allow the server to dial voice, answer call, hold call, and call conference. Besides being able to make a telephone connection, Gammu can also conditioned to send and receive SMS and EMS. Therefore, This service can be used to send messages, download ringtone, caller SMS, send picture, animation, MMS, and VCARD

E. Previous Study

In my previous study^[6], we focused on getting the point h, of the selection which is decision of application, we've applied two kind of method for optimized decision making AHP and Profile Matching. But now we focused on administration and progress of each recruitment and selection procedure for easiness of tracking result and history of the selected employees.

III. METHODOLOGY

A. Research Method

This research is kind of qualitative type of research. We dig a possible solution for agenda process which found at our previous study^[7]

B. Collecting Data Method

The sample selection is using Purposive Sampling technique, which is one of the sampling technique that is often to used in research. Selection of samples are based on informants such as staff, managers, operationals and many other involved with selection process^[8]

C. Design Method

The design technique used in this research is using object-oriented design (OOD) approach. In the design process, the designing techniques are: 1. Database design. Modeled with an entity relationship diagram, 2. Design of static structure of information system specification. Modeled with a class diagram, 3. Designing user interface. Includes the design of navigation, input form, and output form. Modeled using wireframing^[9]

IV. RESULT AND DISCUSSIONS

A. SMS Gateway Design with GAMMU SMS Gateway

1. System Module Design

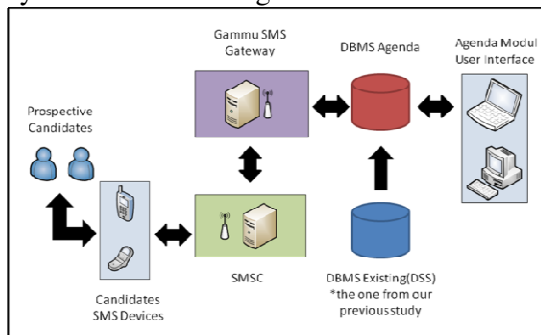

Fig. 1 System Modul Design

In the Fig 1, we explain the agenda design work plan on the user interface module agenda, there is a feature to generate broadcast sms according to generate the entered agenda. Then, on the agenda of the user interface module there is also a feature to send broadcast sms that has been generated and given a list of recipients (whose data is taken from the DBMS Existing DSS) as well as raises the reply received from the candidate. SMS broadcast will be arranged by Gammu SMS Gateway to the SMSC. After going through the SMSC, recipients who are candidates will receive an SMS agenda for psychological tests, user interviews, MCU, socialization of work contracts or onboard.

- Valid True SMS Broadcast Format and Reply SMS Format Design from candidate to sms gateway server, automatic reply based on Database Agenda

SMS format: PSI <space> FLPNumber

Reply format:

Tanggal Agenda **Psikotes / User Interview / MCU/ socialization / Onboard**

Anda:<<dd-mm-yyyy>>, Tempat: <<Test Address Location>>, Waktu: <<hh:mm>>,

PIC: <<PIC Name>>, No Kontak

PIC:<<Handphone Number>>

- Valid False SMS Broadcast Format and Reply SMS Format Design from candidate to sms gateway server, automatic reply based on Database Agenda

Reply format: “Anda tidak memiliki jadwal yang akan berlangsung”, reply is written in indonesian language means you have no schedule that will take a place

- Invalid False SMS Broadcast Format and Reply SMS Format Design from candidate to sms gateway server, automatic reply based on Database Agenda

Reply format: “Format sms yang anda masukan salah. Ketik PSI<spasi>NomorFLP untuk cek agenda psikotes, USI<Spasi>NomorFLP untuk cek agenda user interview, MCU<spasi>NomorFLP untuk cek agenda Tes Kesehatan, SKK<spasi>NomorFLP untuk cek agenda

sosialisasi kontrak kerja atau
OB<spasi>NomorFLP untuk cek agenda

B. Database Design

1. Entity Relationship Diagram

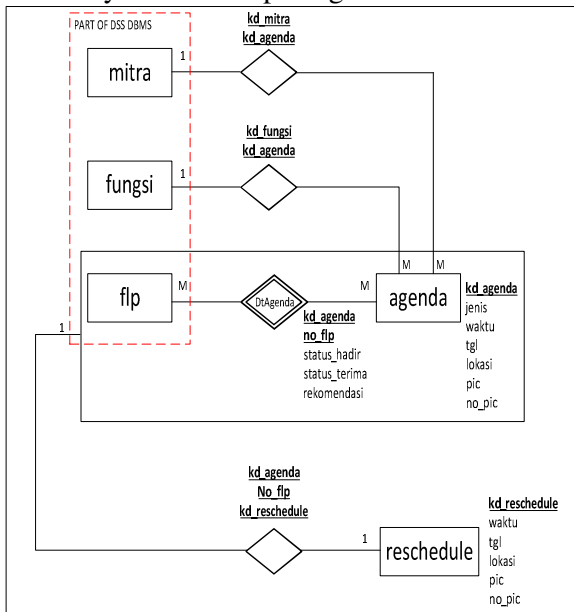

Fig 2. ERD Design

2. Table Specification

As Fig 2 above about ERD Design, there are three tables contain from our previous DSS research that can be used in this study and work as masters for the module(mitra, fungsi and flp). Those three tables integrated with our new database for agenda module. These table bellow will describe the spesification of the new database:

TABLE I
TABLE: AGENDA

Field Name	Type	Size	Description
Kd_agenda	Char	6	Agenda code, Primary key
Kd_mitra	Char	6	Client Code, Foreign key
Kd_fungsi	Char	6	Job Function Code, Foreign key
Jenis	Int	1	Type of Agenda 1 for psycho- logical test 2 for uer interview test 3 for medical check up test 4 for socialization of work contract 5 for on board

Waktu	Time	5	Agenda time, format: hh:mm
Tgl	Date	10	Agenda date, format: dd/mm/yyyy
Lokasi	Varchar	50	Agenda location
Pic	Varchar	30	The name of person in charge for the agenda
no_pic	Varchar	20	Phone number of the person in charge for agenda
TOTAL		134	in kb/record

TABLE II
TABLE: DTAGENDA

Field Name	Type	Size	Description
Kd_agenda	Char	6	Agenda Code, composite key
No_flp	Char	6	Proposal Application form number of candidate, composite key
Status_keh	Int	1	Presence status in agenda, 1 for attend 2 for not attend
Status_terima	Int	1	employee acceptance status 1 for recommended 2 for considered 3 for rejected
recommendati on	Char	6	From function code (user recommend- ation for accepted candidates)
TOTAL		20	in kb/record

TABLE III
TABLE: RESCHEDULE

Field Name	Type	Size	Description
Kd_reschedule	Char	6	Reschedule Code, Primary Key
Kd_agenda	Char	6	Agenda code, Foreign key
Waktu	Time	5	Agenda time, format: hh:mm
Tgl	Date	10	Agenda date, format: dd/mm/yyyy
Lokasi	Varch ar	50	Agenda location
Pic	Varch ar	30	The name of person in charge for the agenda
no_pic	Varch ar	20	Phone number of the person in charge for agenda
TOTAL		127	in kb/record

3. Database Storage Needs

TABLE IV
DATABASE STORAGE ESTIMATION NEEDS

Table	Size	Record	Total
Agenda	134	250	2.010.000
DtAgenda	20	42.000	840.000
Reschedule	127	31.500	4.000.500
TOTAL			6.850.500

C. Display Structure Design

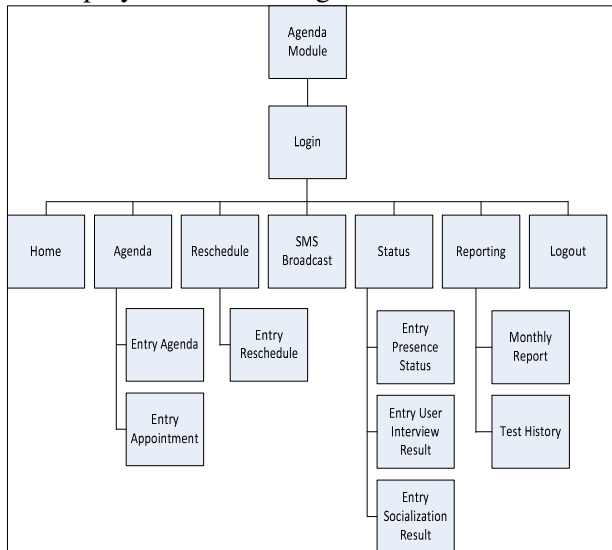

Fig 3. Menu Structure

D. User Interface Design

We include in this paper the example of user interface design that we made in these following fig. 4 and fig. 5

Fig.4. Entry Agenda Page Form

Fig.5 Entry Appointment Page Form

E. Network Access Design

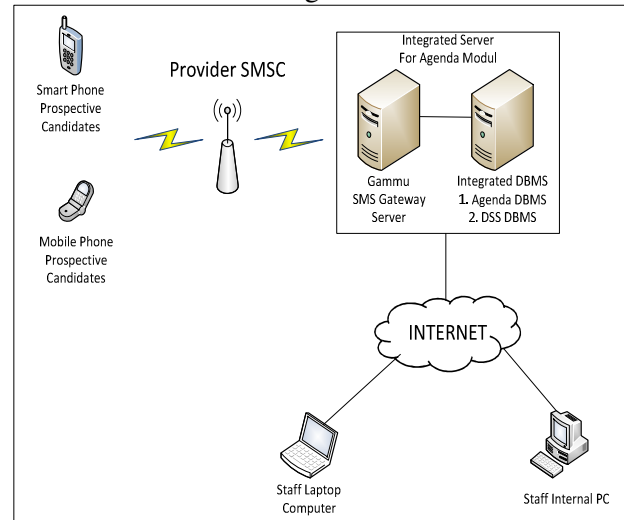

Fig.6 Network Access Design

V. CONCLUSIONS

- A. System module that can bridge the management of these needs is a integration of web based and SMS gateway system. The system can be accessed 24 hours a day
- B. This system can optimized the process of selection process. In selection process there are four different procedures that has the similiar pattern. The pattern that similiar to every each process is "agenda" so we used a generalization scheme to these paterns to optimized and

support every connecting point and administration of those procedures

REFERENCES

- [1] Yuwan Jumaryadi, Tazkiyah Herdi, Riad Sahara, *Analysis and Design of KB/TK Bunga Bangsa Islamic School Information System*, International Research Journal of Computer Science (IRJCS) Issue 04 Volume 5, 2018
- [2] Alan Dennis, Barbara Haley Wixom, Roberta M. Roth, *System Analysis and Design: An Object-Oriented Approach with UML. 5 Edition*, John Wiley & Sons, Inc., United States of America, 2015
- [3] Siagian, Sondang, *Manajemen Sumber Daya Manusia*, Jakarta: Bumi Aksara, Indonesia, 2011
- [4] Marwansyah. *Manajemen Sumber Daya Manusia*, Bandung: Alfabeta, Indonesia, 2010
- [5] Gammu Project, www.gammu.org, accessed September 2018.
- [6] Moedjiono, Nia Rahma Kurnianda, Aries Kusdaryono, *Decision Support Model for User Submission Approval Energy Partners Candidate Using Profile Matching Method and Analytical Hierarchy Process*. Scientific Journal of Informatics, Vol. 3 No. 2, Indonesia, 2016.
- [7] Moedjiono, *Pedoman Penelitian, Penyusunan dan Penilaian Tesis (V.5)*, <http://pascasarjana.budiluhur.ac.id/2012/10/pedoman-tesis-pps-ubl-v5-010112/>, Jakarta: Universitas Budi Luhur, Indonesia, 2012
- [8] Dahlan, M. Sopiudin, *Besar Sampel dan Cara Pengambilan Sampel Dalam Penelitian Kedokteran dan Kesehatan*, Jakarta: Salemba Medik, Indonesia, 2013
- [9] Wardhana, Ariyani. (2018). Design and Implementation of Service Information System in Booking Weight Steam Based on Web. International Journal of Computer Science and Mobile Computing (IJCSMC), Vol. 7, Issue. 2, February 2018, pg.49 - 55.