



Study Regarding the Identification of an Internal Combustion Engine

Ioan Ruja, Elisabeta Spunei, Monica Roșu

The paper presents the results of the scientific investigations performed on an Otto engine. One conducted surveys on the analytic and experimental modelling of the internal combustion engine, considered as automated system element. The results of the analytical study are concretised in the mathematical model of the engine, expressed in the operational. The experimental results are concretised in the indicial response in rotating speed, as well as in the determination of the constants of interest. The investigation methods used in conducting the survey were: experimental identification based on the indicial response of the engine and the analytical identification based on the mathematical models of diverse engine subsystems.

Keywords: *internal combustion engine, identification, mathematical model*

1. Introduction

The article presents the results obtained from the identification study of an internal combustion engine using gasoline as fuel. The research conducted aimed at building a mathematical model for this type of engine. The mathematical model is useful for the specialists who aim at automating the operation of these engines as well as for the realisation of optimum adjustment systems. The research methods used were the inductive methods, based on observations and experiments. According to the engine operation principle and observations, one established the independent and the dependent variables, one issued working hypotheses and one forwarded a block diagram of the studied montage. Analytically, one set the transfer function of the elements presented in the engine structural diagram. After completing these stages, one proceeded to experiments on the engine, raising the indicial response in rotating speed. The results obtained from experiments allowed

the establishment of a mathematical model for the engine and validated the analytical model.

2. Theoretic considerations

The Otto engine subjected to the study is a four-stroke engine with 4 cylinders in line, fuelled by gasoline.

The independent variable is the position of the flap providing the air flow necessary for the mixture with the gasoline flow.

The dependent variable is the rotating speed of the engine crankshaft.

Other additional elements intervene in the study, namely forces, couples, moments, pressures, translations, masses, which concur to the transformation of the thermal energy into mechanical energy.

The following hypotheses are forwarded:

- All the automated system elements intervening in the structural diagram of the engine are linear or have been linearised;
- For the linear elements one applies the Laplace direct transformed, in null initial conditions;
- The resistant couple is null during the experiments, $M_R=0$;
- One neglects the non-linearities due to the play in mechanisms and hysteresis;
- The cam mechanism has one degree of freedom;
- The opening of the admission valve is made with advance, $\tau_1 = (7 \div 20)^\circ$ RAC, from the upper dead centre [4];
- The closure of the admission valve is made with delay, $\tau_2 = (39 \div 70)^\circ$ RAC, from the lower dead centre [4];
- The opening of the discharge valve is made with advance, $\tau_3 = (40 \div 70)^\circ$ RAC, from the lower dead centre [4];
- The closure of the discharge valve is made with advance, $\tau_3 = (5 \div 40)^\circ$ RAC, from the upper dead centre [4];
- The dead centres $\tau_1, \tau_2, \tau_3, \tau_4$ are implemented in the cams profile and shall not be introduced as items in the block diagram;
- The engine operates with a fuel mixture in proportion of 1 g of gasoline to 14.8 g of air;
- $\sigma/l < 0,2$, and the angle $\beta=0$, where:
 - r is the crankpin radius;
 - l is the length of the connecting rod;
 - β is the angle made by the connecting rod with the piston vertical axis.

$$- F_g = P_i \cdot \frac{\pi \cdot D^2}{4} \text{ [N]} \text{ is the force due to the pressure of the}$$

gases resulted from the burning of the fuel mixture in the cylinders, P_i is the average pressure in the cylinders, in nominal regime (6.4÷10.8) N/m² [4];

- $F_i = m_i \cdot a$ [N] is the inertia force of the masses in translation motion in the cylinders, m_i [kg] is the reduced mass of the parts in translation motion, a [m/s²] is the mass acceleration.
- $F = F_g + F_i$ [N] is the resultant force acting in the cylinder body, after combustion (explosion);
- $F_t \cong F \cdot \sin \alpha$ [N] is the tangential force producing the motor moment in the crank shaft;
- The motor moment in the crank shaft produces by force F_t is:

$$M_m \cong F \cdot r \cdot \sin \alpha, \quad (1)$$

where α is the angle made by the crank radius with the cylinder vertical axis;

- The average motor couple is [4]:

$$M_{mot} = \frac{1}{\pi} \int_0^m M_m \cdot d\alpha, \quad (2)$$

- The distribution mechanism (cam shaft) operates according to equation [2]:

$$a_2 \cdot \frac{d^2 y(t)}{dt^2} + a_1 \cdot \frac{dy(t)}{dt} + a_0 \cdot y(t) = F(t), \quad (3)$$

where $y(t)$ is the translation motion at the exit of the mechanism, $F(t)$ is the force of entry to the cam, whereas a_0 , a_1 , a_2 are coefficients depending on the material and dimensions of the distribution mechanism.

- One neglects the small delay time constants.

Taking into consideration the constructive shape of the engine, the operation principle and the work hypotheses, one proposes the structural diagram of the studied engine, presented in Fig. 1.

The transfer functions of the blocks comprise din the structural diagram are:

- The transfer function of the air flap [4]:

$$H_1(s) = K_1, \quad (4)$$

The static characteristic of the air flap is presented in Fig. 2.

- The transfer function of the pressure transducer:

$$H_2(s) = K_2, \quad (5)$$

- The transfer function of the computer:

$$H_3(s) = K_3, \quad (6)$$

- The transfer function of the gasoline injector:

$$H_4(s) = K_4, \quad (7)$$

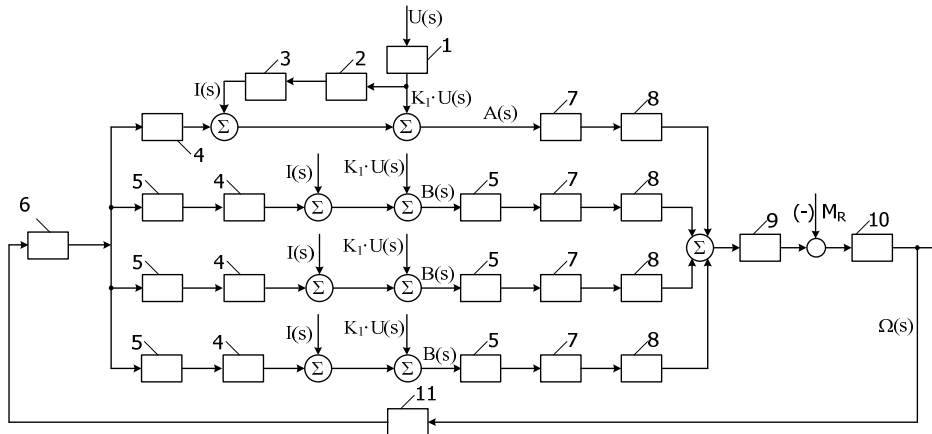

Figure 1. Structural diagram of the spark-ignition engine: 1 – exit flap, 2 – pressure transducer, 3 – computer, 4 – injector, 5 – delay item, 6 – distribution mechanism, 7 – combustion process, 8 – crank-rod piston mechanisms, 9 – proportional element, 10 –dynamic rotation element, 11 – reducing gear.

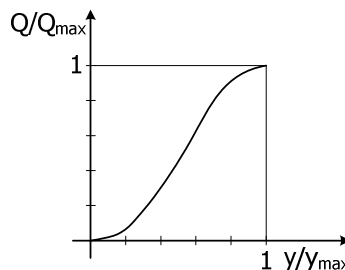

Figure 2. Static characteristic of the air flap.

- The transfer function of the delay item of the spark plugs ignition delay:

$$H_5(s) = \frac{K_5}{1 + s \cdot T_m}, \quad (8)$$

- The transfer function of the distribution mechanism:

$$H_6(s) = \frac{K_6}{a_2 \cdot s^2 + a_1 \cdot s + a_0}, \quad (9)$$

- The transfer function of the combustion chamber (cylinder):

$$H_7(s) = \frac{K_7}{1 + T_1 \cdot s}, \quad (10)$$

- The transfer function of the crank-rod mechanism:

$$H_8(s) = \frac{\omega}{s^2 + \omega^2}, \quad (11)$$

- The transfer function of the force-moment converter ($K_9=T$):

$$H_9(s) = K_9, \quad (12)$$

- The transfer function of the dynamic items for parts in rotation motion:

$$H_{10}(s) = \frac{1}{J \cdot s}, \quad (13)$$

- The transfer function of the reducing gear:

$$H_{11}(s) = K_{11}, \quad (14)$$

where:

- $K_1, K_2, K_3, K_4, K_5, K_6, K_7, K_9, K_{11}$ are the implication factors of the respective items, which depend on its constructive dimensions;
- T_m is the dead centre constant which triggers the ignition in the cylinders;
- T_1 is the delay time constant of the combustion process in the cylinder;
- $\omega = \frac{d\alpha}{dt}$ is the crank angular speed;
- J is the inertia moment reduced to the crankshaft of the masses in rotation motion.

By reducing the structural diagram one obtains the equivalent transfer function:

$$H_0(s) = \frac{K_1 \cdot \omega (1 + K_2 \cdot K_3) \cdot K_7 \cdot K_9 (1 + T_m \cdot s) (a_2 \cdot s^2 + a_1 \cdot s + a_0) (T_m \cdot s + 1 - 3K_5)}{[J \cdot s (1 + T_1 \cdot s) (1 + T_m \cdot s)^2 (s^2 + \omega^2) (a_2 \cdot s^2 + a_1 \cdot s + a_0) - K_7 \cdot K_9 \cdot \omega (1 + T_m \cdot s)^2 K_4 \cdot K_6 \cdot K_{11} - 3K_5^2 \cdot K_7 \cdot K_9 \cdot K_4 \cdot K_6 \cdot K_{11} \cdot \omega]} \quad (15)$$

which is the mathematical model in the operational of the engine studied, were $m > n$ ($m=8, n=4$).

3. Experimental results

The validation of the engine mathematical model, analytically obtained, was made by experimental determinations of the indicial response in rotating speed of the engine and its interpretation.

For the experimental detection of the indicial response one proceeded as follows:

- the engine was testes;
- the indicial response was processed.

A. Explanation of the response

Figure 3 presents the explanatory diagram necessary for the detection and plotting of the indicial response.

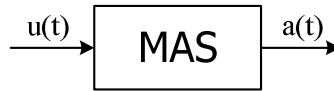

Figure 3. The explanatory of the indicial response.

The engine subjected to testing is a TWINGO D7F engine with the following particulars:

- injection: multipoint;
- ignition: static with 2 monoblock double exit coils;
- supply: with gasoline pump immersed in the tank ($Q=80$ l/h, $p=3$ bar, $U=12$ V) [1];
- pressure: 3 ± 0.2 bar [10];
- injectors ($U=12$ V, $R=(14.5\pm 1)\Omega$) [1];
- stepper adjusting engine in slow motion ($U=12$ V, $R=(53\pm 5)\Omega$) [1];
- $u(t) = \frac{90^\circ}{90^\circ} = 1$ is the unitary step signal applied at the entry by an air flap

(Fig. 4).

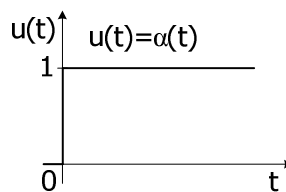

Figure 4. Entry signal.

- $a(t)=n(t)$ is the indicial response of the crankshaft rotating speed.

The function $a(t)$ is recorded with the help of the equipment made of:

- a) Contactless rotating speed transducer, with laser;
- b) computer;
- c) specialise recording software;

Fig. 5. a) and Fig. 5. b) present the position of the flap by which one has generated the unitary step signal $u(t)=1$.

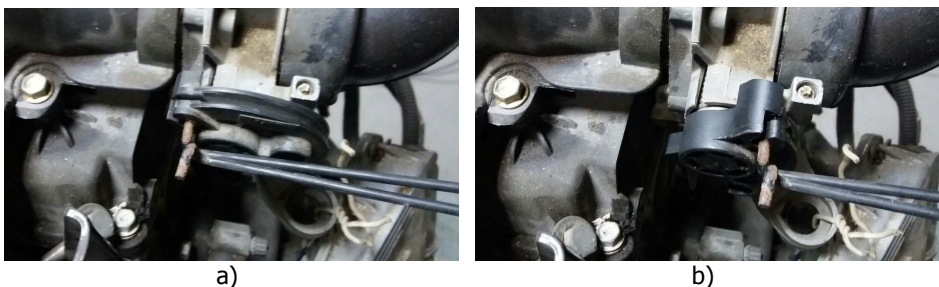

Figure 5. Generation of the unitary step signal: a) $u(t)=0$, b) $u(t)=1$.

$$a(t) = n(t), \quad (16)$$

$$\Omega(t) = \frac{2 \cdot \pi \cdot n(t)}{60}, \quad (17)$$

where n [rot/min] and Ω [rad/s].

Figure 6 presents a view on the equipment by which one recorded the indicial response $a(t)$, and Figure 7 an image with the software used in acquisition.



Figure 6. View on the curve recording equipment $a(t)$.



Figure 7. Rotating speed acquisition software.

B. Processing of the indicial response

Figure 8 presents the indicial response recorded $a(t)$.

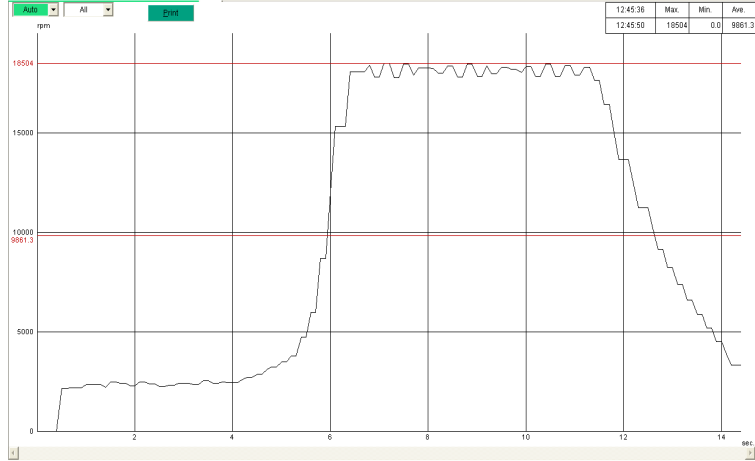

Figure 8. The indicial response $a(t)=n(t)$ of the TWINGO D7F engine.

From the shape of the recorded indicial response it results that the D7F engine is similar with a proportional element with 2 delay time constants.

The transfer function adequate for this system is assimilated with [6]:

$$H_{Mex}(s) = \frac{K}{(1+T_{M1} \cdot s)(1+T_{M2} \cdot s)}, \quad (18)$$

where:

- K is the engine amplification factor;
- T_{m1} , T_{m2} are delay time constants.

By processing the curve presented in Fig. 7, it results: $K= 1$, $T_{m1}=1.02$ [s] $T_{m2}=1.25$ [s].

The function of engine transfer is:

$$H_{Mex}(s) = \frac{1}{(1+1.02 \cdot s)(1+1.25 \cdot s)}, \quad (19)$$

It may be modelled also with the function:

$$H_{Mex1}(s) = \frac{K \cdot e^{-T_m \cdot s}}{(1+T_{M2} \cdot s)}, \quad (20)$$

or

$$H_{Mex1}(s) = \frac{e^{-1.02 \cdot s}}{(1+1.25 \cdot s)}, \quad (21)$$

being equivalent with a proportional elements with the time constant T_{M2} and a dead centre $T_M= T_{M1}$.

5. Conclusion

The following conclusions could be drawn from the study:

- Although the spark ignition engine has a complicated built, the mathematical model is of medium complexity, being equivalent with a PT2-type element;
- The work hypotheses allowed the simplification of the calculations and the obtaining of a mathematical model validated by experiment;
- The use of the transfer function $H_{\text{mex}}(s)$ allows the easy synthesis of a system of engine rotating speed adjustment with a reaction loop and actuated by a PI-type regulator;
- The optimum accord of the regulator allows the reaching of certain performances of transitory and stationary regime required by the beneficiary;
- The modelling may be improved by stricter hypotheses, and the validation perfumed on several types of engines.

References

- [1] ***** TWINGO Engines. The technical book of the D7F engine (in original in Romanian). <http://docauto.ro/manuale-de-reparatii-motoare-renault/>
- [2] Petrescu I., Petrescu V., *Dynamics of the Distribution Mechanisms*, Publisher Lulu, London UK, 2011.
- [3] Petrescu F.I., Petrescu R.V., *Thermal engines* (in original in Romanian), Publisher CreatSpace, 2012.
- [4] Pop B., Bătcă N., Căzilă A., *Thermal engines for motor cars* (in original in Romanian), Dacia Editions, Cluj-Napoca, 1982.
- [5] Landau I.D., *Identification and command of systems* (in original in Romanian), Technical Publishing House, Bucharest, 1997.
- [6] Papadache I., *Industrial automation. Ignition. Applications* (in original in Romanian), Technical Publishing House, Bucharest, 1978.
- [7] Dumitrache I., et. al., *Electronic automations* (in original in Romanian), Didactic and Pedagogic Publishing House, Bucharest, 1993.

Addresses:

- Prof. Dr. Eng. Ioan Ruja, "Eftimie Murgu" University of Reșița, Piața Traian Vuia, nr. 1-4, 320085, Reșița, i.ruja@uem.ro
- Lect. Dr. Eng. Elisabeta Spunei, "Eftimie Murgu" University of Reșița, Piața Traian Vuia, nr. 1-4, 320085, Reșița, e.spunei@uem.ro
- Assist. Drd. Monica Rosu, "Eftimie Murgu" University of Reșița, Piața Traian Vuia, nr. 1-4, 320085, Reșița, m.rosu@uem.ro