

Study of Dynamic Behaviour of Rail Track using Finite Element Method

Hasna P.H
KMEA Engineering College,
Kerala, India
hasna_786@ymail.com, +91 9995593565

Abstract—The track structures subjected to dynamic loading are usually constructed from different materials and components, their behaviour cannot be easily verified or predicted. The design, repair, and effective maintenance of tracks are therefore critical for ballasted track performance assessment. In this study, analytical evaluations were performed to predict and assess the track support stiffness, track impact factor, dynamic wheel-rail forces, and subgrade modulus. The prediction model consists of a three-degrees-of-freedom dynamic track model and modified track properties. The qualitative prediction of model for dynamic track behaviour, capable of simulating the complex interaction between the track's component properties and track responses, was developed in this study. The qualitative analysis results are presented for dynamic explicit analysis of the rail track.

Keywords— Ballasted Track, Solid 186, Track Modulus, Dynamic Load Factor, Static Analysis, Eigen Value Analysis & Dynamic Explicit Analysis

1. INTRODUCTION

Finite element models were developed to simulate the dynamic behaviour of rail track. These models were calibrated against experimental results performed by Mohammad Worya Khordehbinan[14]. To simulate the dynamic behaviour of the experimental setup, a FE model was developed in a commercial FE analysis software package, ANSYS version 14.5. The geometry of reference model is given below. The numerical model adopted is solid finite element (SOLID 186).

Parameter	Track system	Parameter	Track system
Sleeper moment of inertia (cm ⁴)	24200	Elastic modulus of bed (kg/cm ²)	1200
Rail moment of inertia (cm ⁴)	1950	Elastic modulus of Subballast (kg/cm ²)	1200
Ballast thickness (mm)	80	Elastic modulus of ballast (kg/cm ²)	2000
Subballast thickness (mm)	15.2	Elastic modulus of Sleeper (kg/cm ²)	$2.07 \cdot 10^7$
Wheel load (Ton)	14.2	Elastic modulus of rail (kg/cm ²)	$2.07 \cdot 10^9$
Sleeper length (mm)	2600	Bed Poisson's ratio	0.4
Sleeper width (mm)	240	Ballast layer Poisson's ratio	0.4
Sleeper spacing (mm)	61	Sleeper Poisson's ratio	0.1
Rail area (mm ²)	90.5	Rail Poisson's ratio	0.25
Subballast Poisson's ratio	0.3		

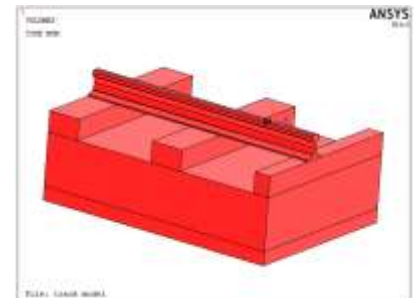
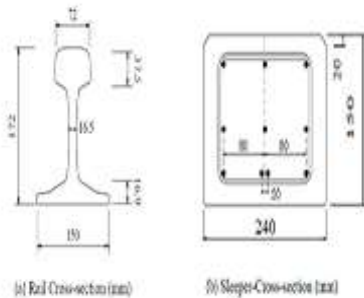

Table1: Track properties used for ANSYS modelling

Fig 1: The Rail and Sleeper Cross-section

Fig 2: FE model of rail track in ANSYS

CALCULATIONS

Here the journal is based on Iranian railway. But practically we need to choose a railway standard which is having some similarity with Iranian railways. Here I'm choosing Indian railway.

As per the Indian Railway Dynamic load factor $\phi = 1 + [V / (3 \cdot \text{SQRT}(U))]$

Where U is Track modulus its unit is (psi)

V is the train velocity in (mph) (adapted from Doyle (1980))

Sample calculation

$$1 \text{ Mpa} = 145.037798 \text{ psi}$$

$$1 \text{ km/hr} = 0.621371 \text{ mph}$$

$$1 \text{ Ton} = 9806.65002864 \text{ Newton}$$

$$\text{Track modulus } U = 32 \text{ Mpa} = 4641.20 \text{ psi}$$

$$\text{Velocity } V = 160 \text{ km/hr} = 99.41936 \text{ mph}$$

$$\text{Dynamic load factor} = \phi = 1 + [99.41936 / (3 \cdot \text{SQRT}(4641.2))] = 1.486$$

$$\text{Quasi static force for 16 tonnes axle force} = \text{Dynamic load factor} \times 16 \text{ Tonnes} = 1.486 \times 16 = 23.776 \text{ Tonnes} = \mathbf{233162.91 \text{ N}}$$

Track modulus (Mpa)	Dynamic load factor ϕ		Quasi static force = Dynamic load factor \times axle load (Newton)			
	160 km/hr	100 km/hr	160 km/hr		100 km/hr	
			16 Tonnes	18 Tonnes	20 Tonnes	25 Tonnes
32	1.486	1.304	233162.914	262308.274	255757.432	319696.79
36	1.458	1.286	228769.531	257365.722	252227.038	315283.797
46	1.405	1.253	220453.492	248010.178	245754.649	307193.311
57	1.364	1.227	214020.329	240772.870	240655.191	300818.988

Fig 3: Deformed Shape displacement of rail from test result

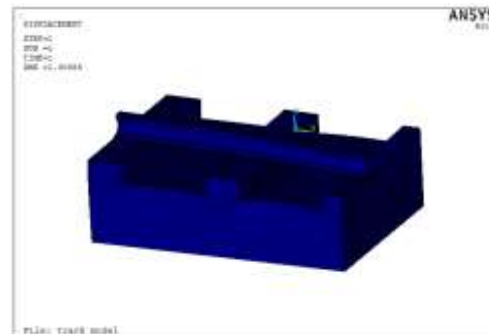

Table2: Effect of track modulus on maximum vertical

RESULTS

Track modulus (Mpa)	Maximum vertical displacement of rail (mm)			
	160 km/hr		100 km/hr	
	Maximum axle passing load		Maximum axle passing load	
	16 Tonnes	18 Tonnes	20 Tonnes	25 Tonnes
32	0.95338	1.07250	1.04580	1.30686
36	0.93541	1.05230	1.03130	1.28920
46	0.90141	1.01410	1.00490	1.25610
57	0.87510	0.98449	0.98401	1.23000

Table 3: Effect of change in track modulus on maximum vertical displacement of rail from ANSYS

Referring to Table 3, it is found that the values of dynamic load factor by finite element technique are almost near approaching the experimental results establishing the soundness of the analysis. The result obtained from ANSYS software is 1.30686 and the corresponding experimental value is 1.304 for a load of 25 tonnes. The variation between numerical result and experimental result is found to be 0.218 %. Hence it can be concluded that the elements, material properties and real constants provided in the analysis are in accordance with the experimental results.

2. Finite Element Analysis

The finite element analysis (FEA) is a computing technique that is used to obtain approximate solutions to boundary value problems. It uses a numerical method called finite element method (FEM). FEA involves the computer model of a design that is loaded and analysed for specific results, such as stress, deformation, deflection, natural frequencies, mode shapes, temperature distributions, and so on. The railway track was modelled and analysed using the finite element software ANSYS 14.5.

ANALYSIS TYPE

a. GENERAL STATIC ANALYSIS

The general static analysis can involve both linear and nonlinear effects and is performed to analyse static behaviour such as deflection due to a static load. A criterion for the analysis to be possible is that it is stable. A static step uses time increments, not in a manner of dynamic steps but rather as a fraction of the applied load. The default time period is 1.0 units of time, representing 100% of the applied load. The nonlinear effects are expected, such as large displacements, material nonlinearities, boundary nonlinearities, contact or friction. It is same as that in table 2 & table 3.

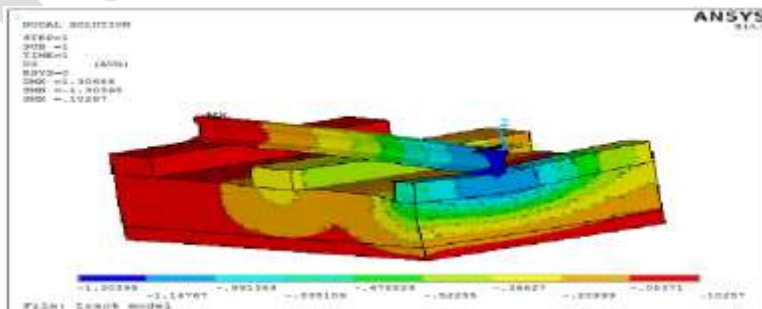

Fig:4 Stress Distribution

CONCLUSION

Conventional track calculations are based on the Static approach. The static analysis has been done for 16 cases. It has been analysed for track modulus 32Mpa, 36Mpa, 46Mpa, & 57Mpa for 16Tonnes, 18Tonnes, 20Tonnes & 25Tonnes at 160 km/hr & 100 km/hr respectively. It is found that the values of dynamic load factor obtained from the finite element analysis are almost near approaching to the calculated values of dynamic load factor. Thus the maximum vertical displacement of rail was obtained as 1.30686mm for the track modulus 32Mpa for 25Tonnes at a speed of 100 km/hr.

b. LINEAR EIGEN VALUE ANALYSIS

Linear eigenvalue analysis is used to perform an eigenvalue extraction to calculate the natural frequencies and corresponding mode shapes of the model.

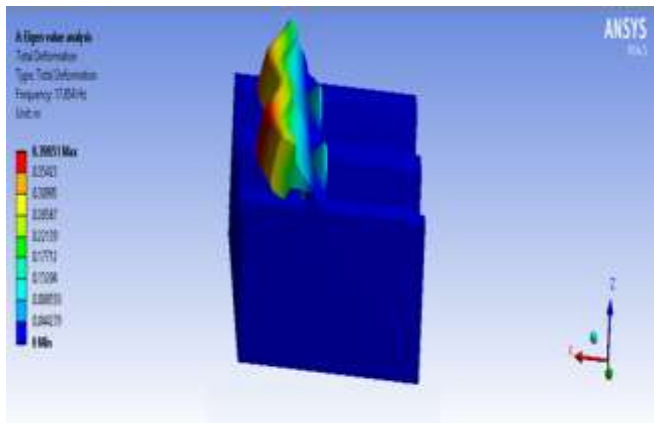

Fig 5: Mode Shape

Mode Numbers	Natural Frequency (Hz)
1	17.854
2	20.409
3	31.995
4	37.001
5	45.516
6	52.296

Table 4: Vibration modes and corresponding natural frequencies

CONCLUSION

Eigen value analysis of the rail track system gives a good picture on the stability of the system. It illustrates the impact of the system on the locations of the eigenvalues. From the above analysis we get different mode shapes and corresponding natural frequencies. Thus the rail track system should be so designed that it should not match with the above mentioned natural frequencies. Hence it shows the number of ways a rail can fail. The eigen value analysis not only depends on the properties of the system, but also on the components used, as well as on the type of software package used.

c. DYNAMIC EXPLICIT ANALYSIS

The design of products that need to survive impacts or short duration high pressure loadings can be greatly improved with the use of ANSYS explicit dynamics solutions. These specialized problems require advanced analysis tools to accurately predict the effect of design considerations on product response to severe loadings. Understanding such complex phenomena is especially important when it is too expensive — or impossible — to perform physical testing.

The ANSYS explicit dynamics product suite helps to gain insight into the physics of short duration events for products that undergo highly nonlinear, transient dynamic events. These specialized, accurate and easy to use tools have been designed to maximise productivity.

With the ANSYS explicit dynamics products, you can study how a structure responds when subjected to severe loadings. Algorithms based on first principles accurately predict responses, such as large material deformations and failure, and interactions between bodies and fluids with rapidly changing surfaces. Here ANSYS Auto-dyn is used for explicit analysis of the rail track.

In order to study the global response of the railway track system due to the passing train load, a new 3-D model was created in ANSYS Workbench, as shown in Figure 7. The model components are all the same as the model created in Figure 2 except the length of the railway track was doubled.

A conventional train model has been used as shown in Figure 6 According to the UIC Code, the technical specifications for Interoperability relating to rolling stock $O_{BA} = 2.6$ m and $O_{BS} = 4.9$ m were taken respectively. And the whole static loading condition

was demonstrated in Table 1. The diameter of the wheel is adopted as 625mm. Loads defined in a static step are directly applied at the joint between wheel and the axle of the wheel in order to find the dynamic effect on the rail.

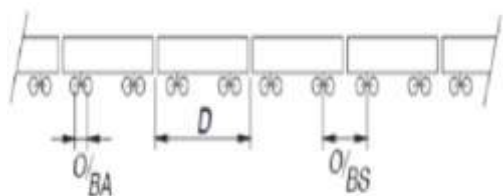

Fig 6: Conventional Train

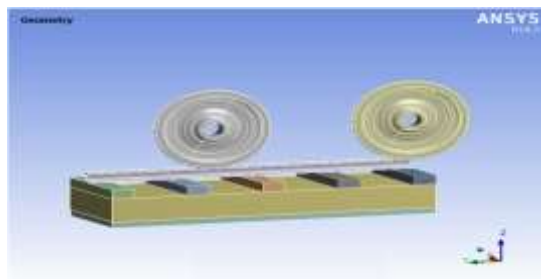

Fig 7: Geometry of the Rail Track Model

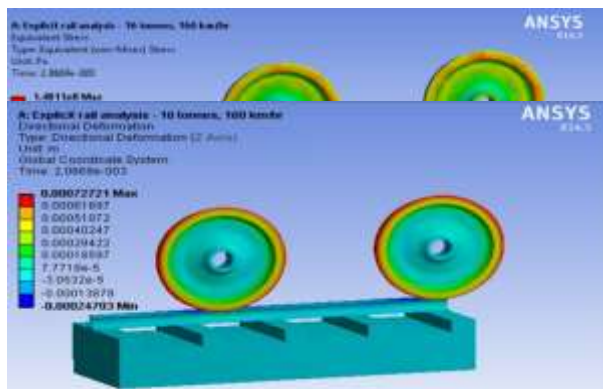

Fig 9: Directional Deformation

Table 6: Directional Deformation

about Z axis

CONCLUSION

Table 5 and 6 shows the results obtained for the analysis of Equivalent (Von Mises) Stress and Directional Deformation in Z axis respectively. The explicit dynamic analysis has been done for a load of 16 tonnes at a speed of 160km/hr for 0.0020669 seconds. A nonlinear stress variation was obtained. While in the case of directional deformation in z axis, a linear variation in vertical displacement of the rail was obtained till 0.0015 seconds and from then the variation was constant till 0.0020669 seconds.

3. STUDY OF DYNAMIC EXPLICIT ANALYSIS ON DIFFERENT SOIL CONDITIONS

The dynamic explicit analysis method is used to calculate the dynamic response of the rail track. The different soil conditions used are: loose sand, medium sand & well graded dense sand. The rail properties are analyzed for Equivalent Stress and Directional Deformation in Z axis. Corresponding variations in the graphs has been drawn to study the dynamic behaviour of rail track.

The importance of using explicit analysis instead of static analysis is that we can directly give the velocity effect to the joint between the wheel and the axle of the wheel. Where as in implicit analysis even though it is a dynamic analysis, only the calculated velocity is given. Here the moving condition is not satisfied. Again it acts as a static case only.

3.1 DIFFERENT TYPES OF SOIL CONDITIONS USED

Soil is our prime natural and economic resource. Soils in India differ in composition and structure. Sand within soil is actually small particles of weathered rock. Sand is fairly coarse and loose so water is able to drain through it easily. Thus sandy soil will not hold water. Here the explicit analysis is carried for three soil conditions: loose sand, medium sand & well graded dense sand. Loose sand have low density. It has a tendency to compress when a load is applied. Whereas dense sand has a tendency to expand in volume when a load is applied.

Fig 8: Equivalent Stress Distribution

F	Time (s)	Minimum Stress (Pa)	Maximum Stress (Pa)
	1.1755e-038	0.	0.
	1.5e-003	0.	2.2321e+008
	2.0669e-003	0.	1.4811e+008

Table 5: Equivalent Stress

Time (s)	Minimum Deformation (m)	Maximum Deformation (m)
1.1755e-038	0	0
1.5e-003	-1.1999e-004	6.9383e-004
2.0669e-003	-2.4703e-004	7.2721e-004

Figure: 10 shows the typical values of soil Young's modulus for different soil conditions such as loose sand, medium sand & dense sand according to USCS. The USCS stands for Unified Soil Classification System. It is a soil classification system used in engineering and geology to describe the texture and grain size of a soil.

3.2 TYPICAL VALUES OF SOIL YOUNG'S MODULUS FOR DIFFERENT SOILS ACCORDING TO USCS

The USCS stands for Unified Soil Classification System. It is a soil classification system used in engineering and geology to describe the texture and grain size of a soil. The different soil conditions used according to USCS are loose sand, medium sand & dense sand. The soil stiffness and modulus of elasticity depends on the consistency and density of the soil.

Typical values of Young's modulus for granular material (MPa) (based on Obrzud & Truty 2012 compiled from Kezdi 1974 and Prat et al. 1995)

USCS	Description	Loose	Medium	Dense
GW, SW	Gravels/Sand well-graded	30-80	80-160	160-320
SP	Sand, uniform	10-30	30-50	50-80
GM, SM	Sand/Gravel silty	7-12	12-20	20-30

Typical values of Young's modulus for cohesive material (MPa) (based on Obrzud & Truty 2012 compiled from Kezdi 1974 and Prat et al. 1995)

USCS	Description	Very soft to soft	Medium	Stiff to very stiff	Hard
ML	Silts with slight plasticity	2.5 - 8	10 - 15	15 - 40	40 - 80
ML, CL	Silts with low plasticity	1.5 - 6	6 - 10	10 - 30	30 - 60
CL	Clays with low-medium plasticity	0.5 - 5	5 - 8	8 - 30	30 - 70
CH	Clays with high plasticity	0.35 - 4	4 - 7	7 - 20	20 - 32
OL	Organic silts	-	0.5 - 5	-	-
OH	Organic clays	-	0.5 - 4	-	-

Fig 10: Typical values of soil Young's modulus

CASE 1: LOOSE SAND

a) EQUIVALENT STRESS

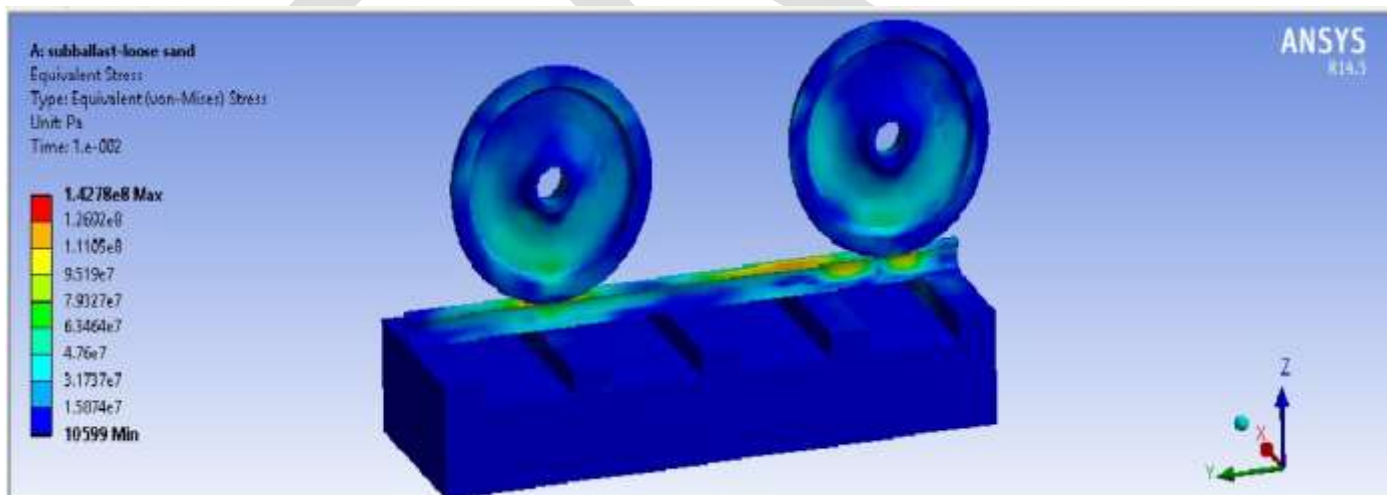

Fig 11: Equivalent Stress in Loose Sand

b) VERTICAL DISPLACEMENT OF RAIL

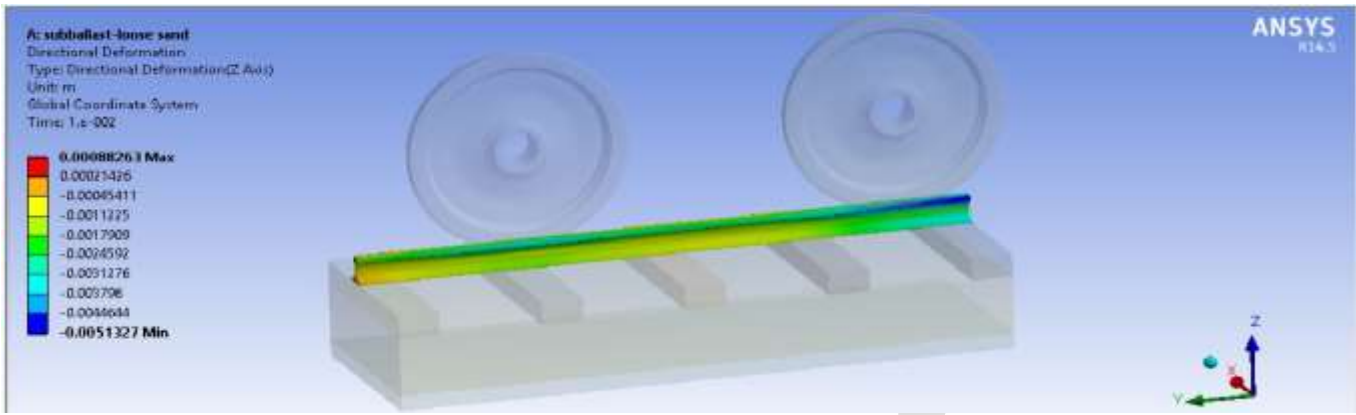

Fig 12: Vertical Displacement of rail track

CASE 2: MEDIUM SAND

a) EQUIVALENT STRESS

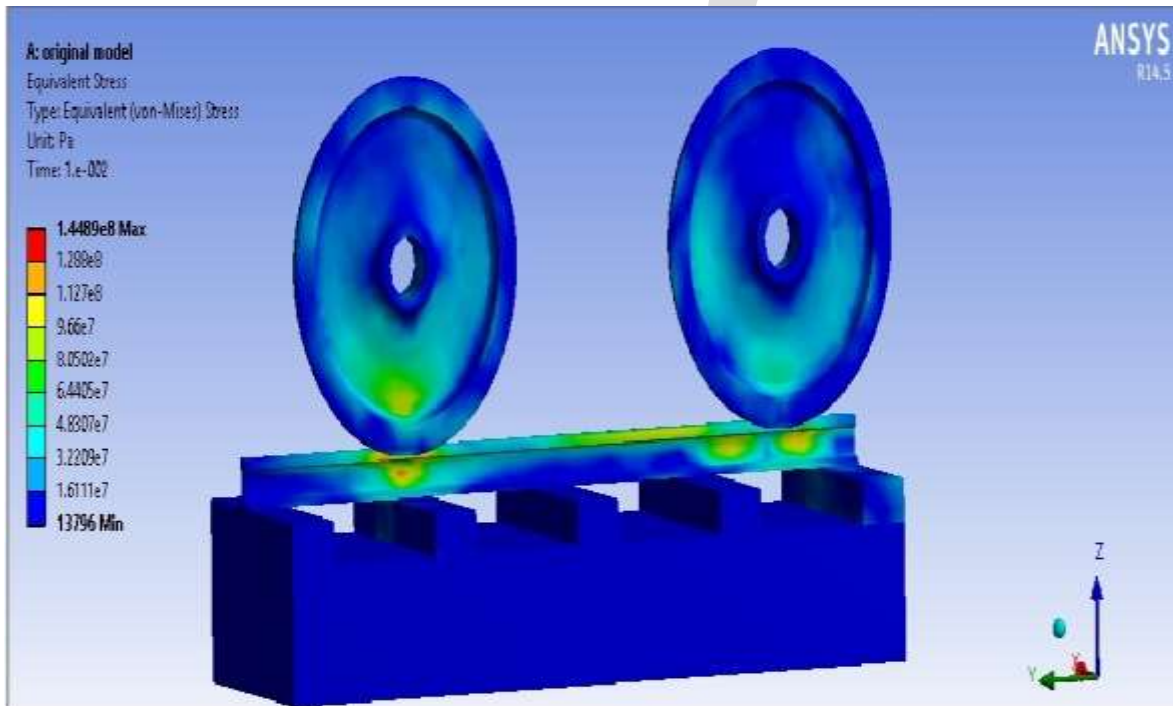

Fig 13: Equivalent Stress in Medium Sand

b) VERTICAL DISPLACEMENT OF RAIL

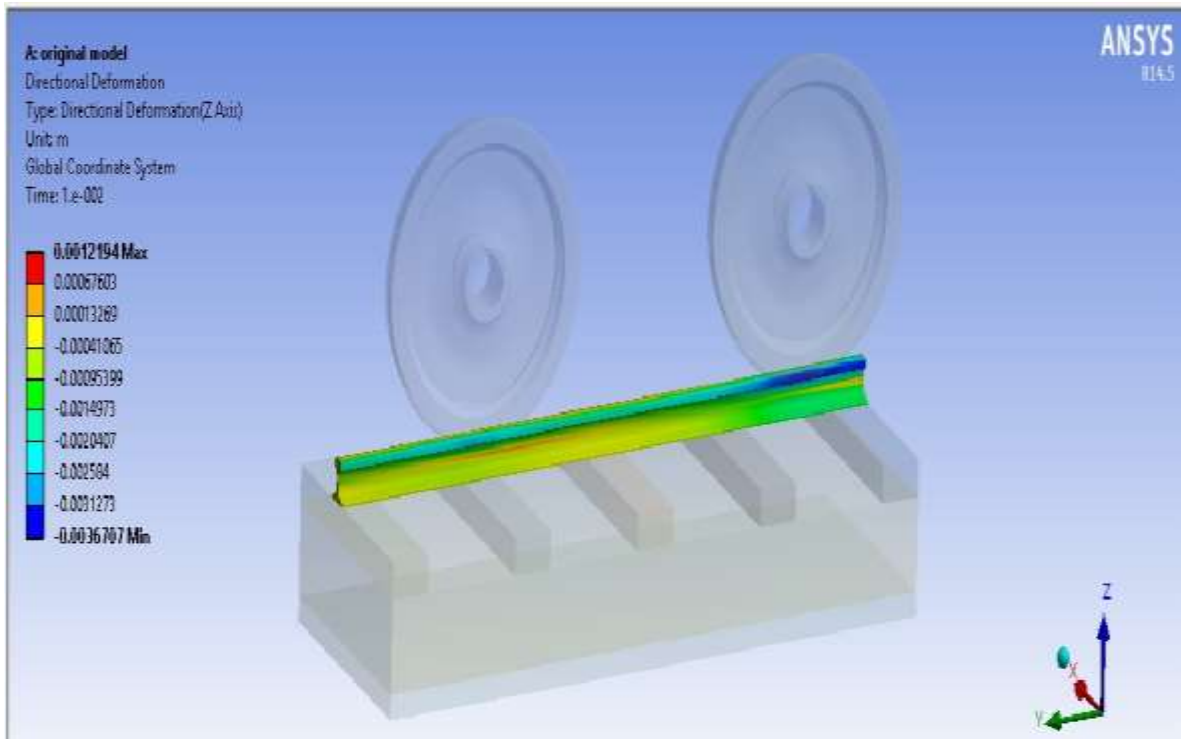

Fig 14: Vertical Displacement of rail track

CASE 3: WELL GRADED DENSE SAND

a) EQUIVALENT STRESS

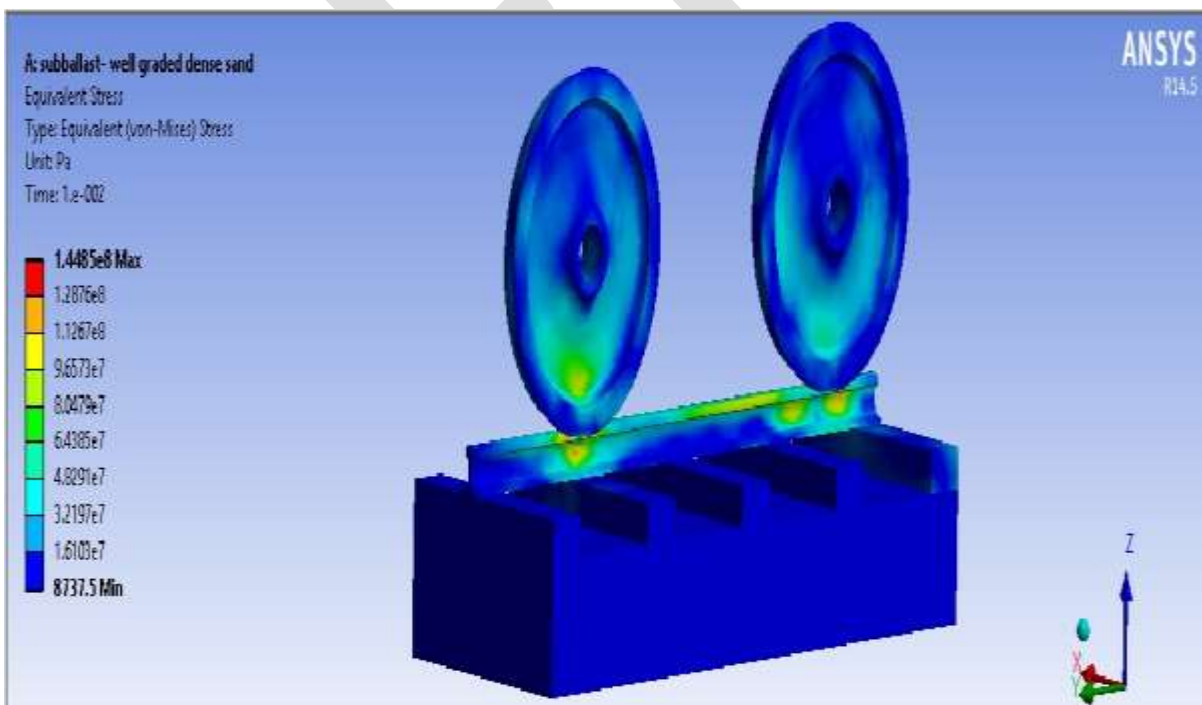

Fig 15: Equivalent Stress in Dense Sand

b) VERTICAL DISPLACEMENT OF RAIL

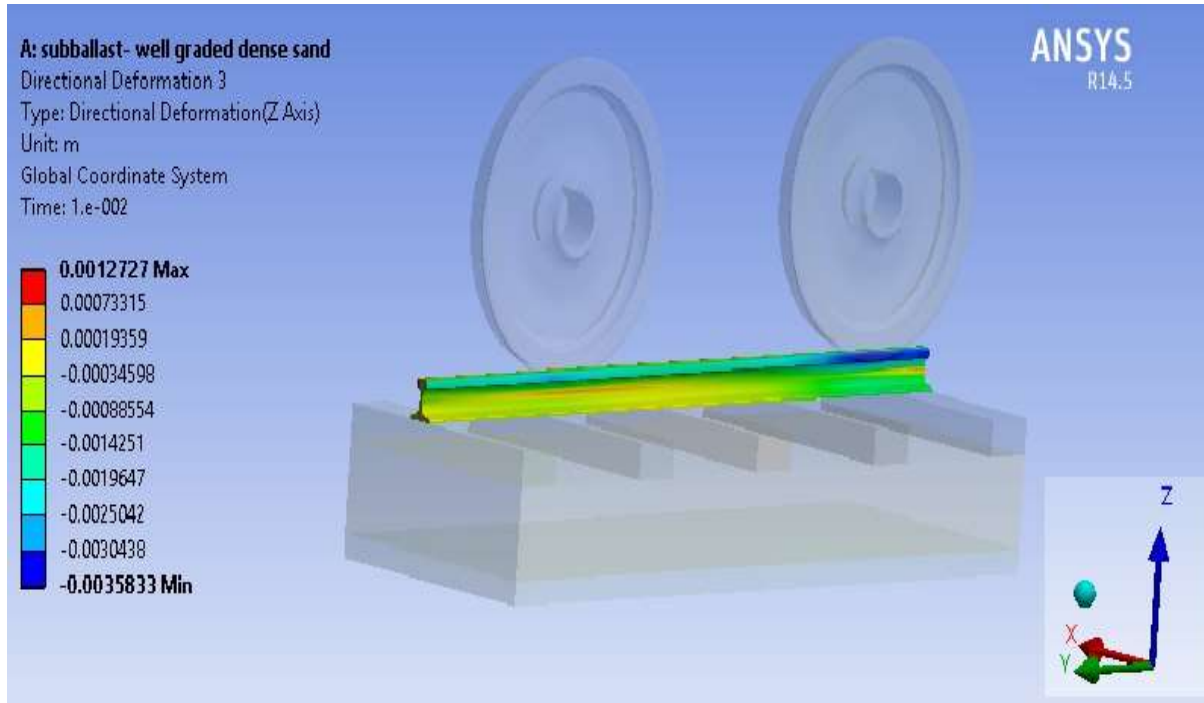

Fig 16: Vertical Displacement of rail track

4. CONCLUSION

The purpose of this thesis was to study the dynamic behaviour of rail track using three dimensional finite element methods. Considering the complexity, different models were created and compared. The comparison on equivalent stresses and vertical displacement of rail for different soil conditions has been performed and their results are compared.

Time (s)	Type of soil	Minimum Stress (Pa)	Minimum Displacement (m)
1.e -002	LOOSE SAND	10599	-5.1327e-003
1.e -002	MEDIUM SAND	13796	-3.6707e-003
1.e -002	WELL GRADED DENSE SAND	8737.5	-3.5833e-003

Table 7: Comparison of results

From table 7 it is found that the minimum stress as well as minimum displacement is obtained for well graded dense sand for 1.e-002 seconds. Thus well graded dense sand can be considered as the better soil for placing the rail tracks.

REFERENCES:

[1] Abdelkrim M., Bonnet G., and Buhari P. [2003], A computational procedure for predicting the long term residual settlement of a platform induced by repeated traffic loading, Computers and Geotechnics 30, 463-476

[2] Alves Costa P., Calçada R., Cardoso A.S., and Bodare A. [2010], Influence of soil non-linearity on the dynamic response of high-speed railway track, Soil Dyn. Earthq. Eng. 30(4), 221 -235.

- [3] Andersson M., Murray M., Ferreira L., and Lake N. [2004], Collection and use of railway track performance and maintenance data. In: Proceedings of CORE 2004– conference on railway engineering, Darwin, Australia.
- [4] Choi J.Y. [2013], Influence of track support stiffness of ballasted track on dynamic wheel-rail forces, *Journal of Transportation Engineering*, 139, 709-718.
- [5] De Man A.P. [2002], DYNATRACK: A survey of dynamic railway track properties and their quality, Ph.D. Thesis, Faculty of Civil Engineering, Delft University of Technology, The Netherlands.
- [6] Prof.Dr.Ir. C. Esveld , Dr.Ir. A.W.M. Kok [2011], “Interaction between moving vehicles and railway track at high speed” *International Journal of Engineering and Applied Sciences*.
- [7] AK Gupta [2006], “ Modeling rail wheel-flat dynamics” Indian Institute of Technology, Kanpur 208 016, India WCEAM 2006 Paper 233.
- [8] Gustavson R. [2000], Static and dynamic finite element analyses of concrete sleepers, Licentiate of Engineering Thesis, Department of Structural Engineering, Chalmers University of Technology, Sweden.
- [9] Hall L. [2002], Simulations and analyses of train-induced ground vibrations infinite element models, *Soil Dynamics and Earthquake Engineering*, 23, 403-413.
- [10] Huan , Feng [2011], “3D-models of Railway Track for Dynamic Analysis” *International Journal of Engineering and Applied Sciences*.
- [11] Hugo Baleia , Casal [2010], “Dynamic behaviour of high-speed railway bridges with ballastless track” Civil engineering Department, Instituto Superior Técnico, Universidade Técnica de Lisboa, Portugal.
- [12] He H., Fu Z. [2001]. *Modal Analysis*, Butterworth - Heinemann Publishers, Great Britain. Indraratna, B. and Salim, W. [2005]. *Mechanics of Ballasted Rail Tracks A Geotechnical Perspective*. Taylor & Francis, London.
- [13] Hunt G.A. [2005], Review of the effect of track stiffness on track performance, Research Project T372, AEATR-II-2004-018, Rail Safety and Standards Board.
- [14] Mohammad Worya Khordehbinan [2010], Investigation on the Effect of Railway Track Support System Characteristics on the Values of Track Modulus.
- [15] Jiannan Yang¹, David Thompson¹ and Atul Bhaskar² [2013], “Dynamic models of railway track taking into account of cross-section deformation at high frequency” Institute of Sound and Vibration Research, University of Southampton, Southampton SO17 1BJ, UK.