

# A Review: Varying bit rate data transmission for long haul system in optical communication

Mandeep kaur<sup>[1]</sup> Atul mahajan<sup>[2]</sup>

<sup>[1]</sup>M-Tech Scholar, Department of Electronics & Communication Engineering  
ACET, Amritsar, India Email:deepboparai23@gmail.com

<sup>[2]</sup>Associate professor, Department of Electronics & Communication Engineering  
ACET, Amritsar, India

**Abstract:** Now a day as per requirement of user we require that high data rate along with good quality of service, this requirement can be full fill by using optical fiber communication, but still telecommunication expanding day by day so that we need more good quality factor per bit rate. by increasing the demand of telecommunication we need more bandwidth. We expanding bandwidth day by different method but this not effective method for full fill requirement. in this review paper use single frequency and single bandwidth and vary the bit rate then at what rate quality factor vary and at what level we get good quality factor. By this we can use different bit rate at single bandwidth and by this our bandwidth spectrum get enhanced for telecommunication.

**Keyword:** optical fiber, telecommunication, spectrum, quality factor, bandwidth, dispersion, bit rate.

## I. INTRODUCTION

With the rapid development of the following generation of optical fiber transmission, optical fiber transmission system and its wave length optical fiber transmission system and its wavelength division multiplexing system has now been the focus of research. to be able to enhance the ability of the machine and diminish the degradation of performance would will be brought on by the increased loss of transmission [1]. by varying the bit rate per-channel according to demand of telecommunication we want high spectral efficiency [2].

## II. OPTICAL COMMUNICATION SYSTEM REVIEW:

An optical communication link is really a means for transmitting data from one place to another using the light source. A simple Optical Communication Systems was made of a transmitter produces the light signal, a visual fiber channel which carries the light and a visual receiver which receives the light signal transmitted for retrieving the information. The device could has additional components such as fiber amplifiers for regenerating the optical power or dispersion compensators for counteracting the consequences of dispersion. The difficulties of the implementation of the optical systems vary from noncomplex (i.e., local area network) to extremely complex and costly (i.e., long term telephone or cable TV network) [3]. The notion of utilizing a glass fiber to transmit information light over long distances was initially introduced by Kao and Hockman in 1966 [4]. This was realized when low-loss glass optical fibers were first fabricated by Arriving 1970 almost at once, room temperature operating semiconductor diode lasers were produced by Bell Labs [5]. The mixture of a concise optical transmission medium and a miniature diode laser produced a series of revolutions in fiber optical communication technology. This technology was adapted by the telecommunication industry starting in the 1970s. At present optical fiber communication systems are widely applied in different types of systems, such as long term telephone network, Cable or Community Antenna television (CATV) networks, broadband Internet services etc., due to the ever-increasing demand for higher data rates in the transmission of multimedia services like voice, image, video, etc. The maturing of fiber optic technology and communication networks have been gradually updated with the seek out more advance techniques to take full advantageous asset of the transmission potential of a fiber link. Techniques like Dense Wavelength Division Multiplexing (DWDM), optical amplifiers, optical switchers, management of dispersion, and optical burst switching etc. enable us to load more transmission traffic onto an individual glass fiber [6]. However, the pursuing for speed and bandwidth never stopped. Theoretically an individual mode fiber features a potential bandwidth of nearly 50 Tbps. With optical fiber networks we were able to achieve link capacities of the order of 1000s of Gbps [4]. The Dispersion limits the utmost transmission data rate and maximal distances of which electronic repeaters should be positioned along optical link [1]. In the Single-Mode Fiber (SMF) the dominant linear impairments are Group-Velocity Dispersion (GVD) i.e., different frequencies travel at different speeds and Polarization-Mode Dispersion (PMD) i.e., different polarizations arrive at the receiver with various delays. The after effect of chromatic dispersion becomes more and more critical at high data rate transmission, since the linear dispersion tolerance decreases with the square of the bit rate [7]. at high data rate dispersion should be compensate by suitable method so that people get good results.

## III. DISPERSION COMPENSATION TECHNIQUES

A SMF features a potential bandwidth of nearly 50 Tbps; with optical fiber networks we could achieve link capacities of the order of 1000s of Gbps [4]. Dispersion limits the most transmission rate and maximal distances at which electronic repeaters should be positioned over the optical link [1]. In the SMF fiber the dominant linear impairments are GVD and PMD. The effect of chromatic dispersion becomes more and more critical at high data rate transmission because the linear dispersion tolerance decreases with the square of the bit rate [8]. It's been observed that dispersion of a standard single mode fiber is lowest at 1300 nm, whereas it's minimum attenuation at 1550 nm. But at 1500 nm wave length the dispersion is higher. The usage of dispersion shifted and dispersion flattened fibbers are a number of the common solutions for compensation [7] There are several different ways that can be utilized to compensate for dispersion, including DCF, chirped Bragg gratings, all-pass optical filters and optical phase conjugation [3]. These

methods restore the signal such that it may be received in a standard receiver. An alternate method would be to detect the dispersed signal and perform the dispersion compensation electrically[2].

#### IV.THEORY

To upgrade the existing optical network by varying the bit rate we want that system should have the exact same amplifier spacing as existing system[2]. Fiber input power is fixed due to the non linear optical effects in the transmission fibre.if we vary the bit rate at that time the interaction between self-phase modulation and group velocity dispersion cause severe wave form distortion in the transmission. For over come these non linear impairments we've several techniques that individuals found in telecommunication for long run system we want the defining the allowable fiber input power in transmission link[3].if we put frequency and bandwidth non variable and we change the data rate differently than we get many quality factor for the reason that case bandwidth spectrum get enhanced. in this way our telecommunication demand should be full fill. In one single channel optical communication system for lower channel power, the most transmission length is set by the accumulated amplifier noise in the system, and for higher channel power, the system behaviour is limited through the non linear effects in the fibre such as for instance spm. Although dispersion compensation at the end of each fiber span can correct for the waveform distortion. [12]

The schematic of the optical communication system simulation setup is shown

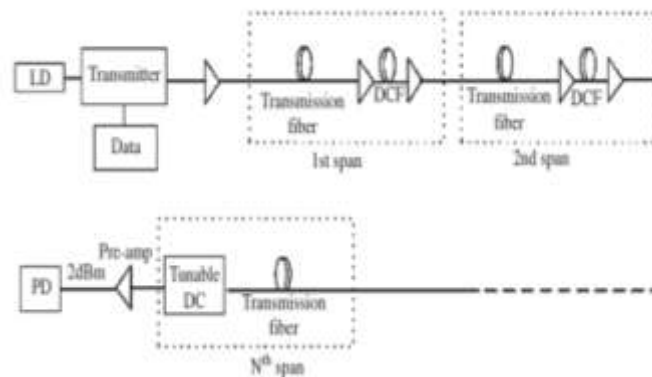

Fig.1. optical communication system setup[2]

#### V.ADVANTAGES OF OPTICAL FIBER IN TELECOMMUNICATION:

**1.Immunity to Electromagnetic Interference** Although fiber optics can solve data communications problems, they are not required everywhere. Most computer data explains ordinary wires. Most data is sent over short distances at low speed. In ordinary environments, it's not practical to use fiber optics to transmit data between personal computers and printers as it's too costly. Electromagnetic Interference is just a common kind of noise that originates with one of many basic properties of electromagnetism. Magnetic field lines generate an electrical current while they cut across conductors. The flow of electrons in a conductor generates a magnetic field that changes with the existing flow. Electromagnetic Interference does occur in coaxial cables, since current does cut throughout the conductor. Fiber optics are immune to this EMI since signals are transmitted as light as opposed to current. Thus, they are able to carry signals through places where EMI would block transmission.[9,10,]

#### 2. Data Security

Magnetic fields and current induction work in two ways. They don't just generate noise in signal carrying conductors; additionally they let the data on the conductor to be leaked out. Fluctuations in the induced magnetic field outside a conductor carry exactly the same information as the existing passing through the conductor. Shielding the wire, as in coaxial cables can reduce the problem, but sometimes shielding can allow enough signal leak to permit tapping, which is exactly what we wouldn't want. You can find no radiated magnetic fields around optical fibers; the electromagnetic fields are confined within the fiber. That makes it impossible to tap the signal being transmitted via a fiber without cutting into the fiber. Since fiber optics do not radiate electromagnetic energy, emissions can't be intercepted and physically tapping the fiber takes great skill to accomplish undetected. Thus, the fiber is the absolute most secure medium available for carrying sensitive data. **3. Eliminating Spark Hazards**

Sometimes, transmitting signals electrically can be extremely dangerous. Most electric potentials create small sparks. The sparks ordinarily pose no danger, but can be really bad in a chemical plant or oil refinery where the air is contaminated with potentially explosive vapours. One tiny spark can cause a big explosion. potential spark hazards seriously hinder data and communication such facilities. Fiber optic cables do not produce sparks since they cannot carry current.

#### 4. Ease Of Installation

Increasing transmission capacity of wire cables generally makes them thicker and more rigid. Such thick cables can be difficult to put in existing buildings where they need to proceed through walls and cable ducts. Fiber cables are easier to put in being that they are smaller and more flexible. They could also run along exactly the same routes as electric cables without picking right up excessive noise.

## 5. High Bandwidth

Over Long Distances Fiber optics have a big capacity to carry top speed signals over longer distances without repeaters than other forms of cables. [9,10,]

## VI.PROBLEMS WITH FIBER OPTICS

### 1.System Reconfiguration

Although fiber optics are renowned for his or her efficiencies and plenty of advantages, there are a few drawbacks in them and one of them is system reconfiguration. Converting existing hardware and software for the utilization of fiber optics does take plenty of time and money which also reduces the turnover for just about any profit making firm in the market. Sometimes it may be far more convenient to transmit top speed computer data serially ( one bit after another ) than sending several bits at a time in parallel over separate wires. This changeover requires modification in both hardware and software.

### 2. Limitations in Local Area Networks

In Local Area Networks, fiber optics is not used as widely as you might expect. One reason is the implementation requires lot of changes in current networks and systems. This involves plenty of time and effort that your management is not ready to sacrifice.

### 3. Economic Evaluation

The major practical problem with fiber optics is that it always costs more than ordinary wires. All costs elements associated with economic evaluation may be grouped into two main classes; which are investment costs and operation costs. [9,10]

## VII.APPLICATION OF OPTICAL FIBER IN TELECOMMUNICATION

- Low signal loss and high bandwidth.
- Small size and banding radius.
- Non conductive, non radiative, non inductive.
- Light weight. [10,11]

## VIII.CONCLUSION :

We conclude that for good quality factor needs non linear distortion compensating technique are required without these techniques we does not able get better result and if we vary the bit rate at single frequency and bandwidth in that case our bandwidth spectrum get enhanced. it give better result for telecommunication.

## REFERENCES:

- [1] Aihan yin, Libi, Xinliang zhang “analysis of modulation format in the 40 gbits/s optical communication sysytem” optic 121 (2010) 1550-1557
- [2] Anu sheetal, Ajay k. Shrama, R.S. kaler “impact of optical modulation format on SPM-limited fiber transmission in 10 and 40 gb/s optimum dispersion-managed lightwave system ” optik 121 (2010) 246-252.
- [3] R.K.sethi, Dr. Aditya goel “ performance analysis of optical communication system using OFDM by employing QPSK modulation” international journal on recent and innovation trends in computing and communication.

- [4] K. C. Kao and G. A. Hockman, "Dielectric Fiber Surface Waveguides for Optical Frequencies," Proc. IEE, Vol. 133, pp. 1151-1158.
- [5] C. Lin, "Optical Fiber Transmission Technology - Handbook of Microwave and Optical Components", Ed. K. Chang, John Wiley, 1991.
- [6] Bo huang, Yi An, Nan Chi, Meng Xiong, Haiyan ou, Wen Liu, Christophe peucheret "combining DPSK and duobinary for the downstram in 40-Gb/s long-reach WDM-PONs" optical fiber technology 19 (2013) 179-184.
- [7] Neeru Malhotra, Manoj kumar " investigation on PMD-induced penalties in 40 Gbps optical transmission link" optik 121 (2010) 286-290.
- [8] K.K.gan, B.abi, W. Fernando, H.P. kagan, R.D. kass, A. Law, M.R.M. lebbai, F.Rizatdinova, P.L. skubic, D.S.smith " radiation-hard/ high speed data transmission using optical links" nuclear instruments and methods in physis research A.
- [9] Arun gangwar, Bhawana sharma "optical fiber : the new era of high speed communication (technology, advantages and future aspect)" international journal of enginnering research and development.
- [10] Francis idachaba Dika v ike, orowwode hope " future trends in fibre optics commuication" proceeding of the world congress on engineering 2014 vol 1
- [11] Joseba zubia, Jon arrue "plastic optical fibers an introduction to their tehnology processes and application" optical fiber technology 7,101-190(2001).
- [12] Erwan pincemin, Julie karakai, Yann Loussouarn, Hubert poignant, Christophe betoule, Gilles theouenon, Raphael Le Bidan " challenges of 40/100 gbps and higher rate deployments over long haul transport networks" optical fiber tehnology 17(2011) 335-362